

Instruction and Operation Manual

S452

Thermal Mass Flow Meter for Heavy Duty and Ex Applications (Inline)



Dear Customer,

Thank you for choosing our product.

Please read the operating instructions in full and carefully observe them before starting up the device. The manufacturer cannot be held liable for any damage which occurs as a result of non-observance or non-compliance with this manual.

Should the device be tampered with in any manner other than a procedure which is described and specified in the manual, the warranty is void and the manufacturer is exempt from liability.

The device is designed exclusively for the described application.

SUTO offers no guarantee for the suitability for any other purpose. SUTO is also not liable for consequential damage resulting from the delivery, capability or use of this device.

Table of Contents

1 Safety instructions.....	4
2 Registered trademarks.....	6
3 Application.....	7
4 Features.....	7
5 Technical data.....	8
5.1 General data.....	8
5.2 Electrical data.....	9
5.3 Output signals.....	9
5.4 Accuracy	9
5.5 Flow ranges.....	9
6 Dimensional drawing.....	11
6.1 Thread type.....	11
6.2 Flange type.....	12
7 Determining the installation point.....	14
7.1 Additional inlet and outlet sections.....	15
8 Installation	16
8.1 Install the S452.....	16
8.2 Remove the S452	17
8.3 Re-install after maintenance.....	17
8.4 Electrical connection	18
8.4.1 Connection diagram.....	18
8.4.2 Pin assignment.....	18
9 Signal outputs.....	20
9.1 Analog and pulse outputs	20
9.1.1 Analog output.....	20
9.1.2 Pulse output.....	20
9.2 HART output	22
9.3 Modbus Interface	22
9.4 M-Bus output	24
9.5 Connection between S452 Outputs and Customer Equipment.....	25
10 Information on the Display.....	28
10.1 Startup.....	28
10.2 Data and Signs.....	29
11 Configuration.....	30
12 Optional accessories.....	32
12.1 Display.....	32
12.2 Service kit.....	32
13 Calibration.....	32
14 Maintenance.....	33
15 Disposal or waste.....	33

1 Safety instructions

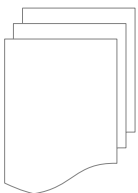

Please check if this instruction manual matches the product type.

Please observe all notes and instructions indicated in this manual. It contains essential information which must be observed before and during installation, operation and maintenance. Therefore this instruction manual must be read carefully by the technician as well as by the responsible user or qualified personnel.

This instruction manual must be available at the operation site of the flow meter at any time. In case of any obscurities or questions, regarding this manual or the product, please contact the manufacturer.



WARNING!

Compressed air!

Any contact with quickly escaping air or bursting parts of the compressed air system can lead to serious injuries or even death!

- Do not exceed the maximum permitted pressure range (see sensors label).
- Only use pressure tight installation material.
- Avoid that persons get hit by escaping air or bursting parts of the instrument.
- The system must be pressureless during maintenance work.



WARNING!

Voltage used for supply!

Any contact with energized parts of the product, may lead to a electrical shock which can lead to serious injuries or even death!

- Consider all regulations for electrical installations.
- The system must be disconnected from any power supply during maintenance work.
- Any electrical work on the system is only allowed by authorized qualified personal.

**ATTENTION!****Permitted operating parameters!**

Observe the permitted operating parameters, any operation exceeding this parameters can lead to malfunctions and may lead to damage on the instrument or the system.

- Do not exceed the permitted operating parameters.
- Make sure the product is operated in its permitted limitations.
- Do not exceed or undercut the permitted storage and operation temperature and pressure.
- The product should be maintained and calibrated frequently, at least annually.

General safety instructions

- It is allowed to use the product in explosive areas. Please contact the manufacturer.
- Please observe the national regulations before/during installation and operation.

Remarks

- It is not allowed to disassemble the product.
- Always use spanner to mount the product properly.

**ATTENTION!****Measurement values can be affected by malfunction!**

The product must be installed properly and frequently maintained, otherwise it may lead to wrong measurement values, which can lead to wrong results.

- Always observe the direction of the flow when installing the flow meter. The direction is indicated on the housing.
- Do not exceed the maximum operation temperature at the sensors tip.
- Avoid condensation on the sensor tip as this will affect the accuracy enormously.

Storage and transportation

- Make sure that the transportation temperature of the flow meter without display is between -30 ... +70°C and with display between -10 ... +60°C.
- For transportation it is recommended to use the packaging which comes with the flow meter.
- Please make sure that the storage temperature of the flow meter is between -10 ... +50°C.
- Avoid direct UV and solar radiation during storage.
- For the storage the humidity must be <90% with no condensation.

2 Registered trademarks

SUTO®	Registered trademark of SUTO iTEC
MODBUS®	Registered trademark of the Modbus Organization, Hopkinton, USA
HART®	Registered trademark of HART Communication Foundation, Austin, USA
Android™, Google Play	Registered trademarks of Google LLC

3 Application

The S452 Thermal Mass Flow Meter is designed for the explosive areas and is mainly used to measure compressed air and process gases in industrial environments.

The S452 can measure the following parameters for the compressed air or gases:

- Velocity
- Volume flow
- Total consumption

The default factory settings are: Velocity in m/s, Volume flow in m³/h and Total Consumption in m³. Other units can be programmed by the optional display or the service kit.

4 Features

- Direct measurement of mass flow and standard flow without the need of pressure and temperature compensation.
- In-line types for smaller pipes.
- No moving parts, no clogging.
- All sensor parts which come into contact with the measurement medium are made of stainless steel 316L.
- Robust metal enclosure suitable for outdoor applications in harsh environments.
- Wireless Bluetooth interface for settings onsite
- Optional display on the flow meter, showing flow rate, consumption, medium temperature and diagnostic result.

5 Technical data

5.1 General data

CE	
Measuring range	0.4 ... 92.7 sm/s (standard range calibration) 0.8 ... 185 sm/s (max range calibration) 1.0 ... 224 sm/s (high speed calibration) (See section Flow ranges for flow measurement ranges in different tube diameters) * sm/s: standard meter per second
Parameters	Standard unit flow: m ³ /h Available units: m ³ /min, l/min, l/s, cfm, kg/h, kg/min, kg/s Standard velocity unit: m/s
Reference conditions	ISO1217, 20°C, 1000 mbar (Standard-Unit) DIN1343, 0°C, 1013.25 mbar (Norm-Unit)
Principle of measurement	Thermal mass flow
Sensor	PT20 / PT1000
Measured medium	Air, gas (non corrosive gas)
Operating temperature	-40 ... +100°C (medium temperature) -40 ... +65°C (ambient temperature)
Humidity of the measured medium	< 90%, no condensation
Operating pressure	0 ... 4.0 MPa
Housing material	Al alloy
Material of the probe tube, sensor head and the screwing	Stainless steel 1.4404 (SUS 316L)
Protection class	IP67
Dimensions	See Chapter Dimensional drawing .
Display (optional)	Graphic display, 128 x 64
Tube diameter	DN15 ... DN80
Screwing thread	M32 x 1.5

Weight	1.25 kg (instrument only, and the measuring section is not included)
--------	--

5.2 Electrical data

Power supply	16 ... 30 VDC, 5 W
--------------	--------------------

5.3 Output signals

Analog output	See section 9.1.1
Pulse output	See section 9.1.2
HART output	See section 9.2
Modbus output	See section 9.3
M-Bus output	See section 9.4

5.4 Accuracy

Accuracy*	$\pm(1.5\% \text{ of reading} + 0.3\% \text{ full scale})$
Stated accuracy at:	Ambient/process temperature $+23^{\circ}\text{C} \pm 3^{\circ}\text{C}$ Ambient/process humidity $<90\%$, no condensation Process pressure at 0.6 MPa
Repeatability	0.25% of reading

* The specified accuracy is valid only within the minimum and maximum flow rates that are stated in Section 5.5.

5.5 Flow ranges

The stated flow ranges are valid under the following conditions:
Standard flow in air; Reference pressure: 1000 hPa; Reference Temperature: $+20^{\circ}\text{C}$

Inch	DN	S-Range (m ³ /h)	M-Range (m ³ /h)	HS-Range (m ³ /h)
½"	DN15	0.2 ... 45.6	0.4 ... 91.0	0.48 ... 110
¾"	DN20	0.4 ... 89.1	0.9 ... 178	1.09 ... 215
1"	DN25	0.6 ... 148	1.2 ... 295	1.82 ... 357
1½"	DN40	1.5 ... 367	2.9 ... 732	4.36 ... 886
2"	DN50	2.4 ... 600	4.8 ... 1,198	7.26 ... 1,450
2½"	DN65	4.1 ... 1,027	8.2 ... 2,049	--
3"	DN80	5.7 ... 1,424	11.4 ... 2,841	--

Remarks:

- To calculate flow ranges based on pipe and reference conditions in your site, download and install the "Flow range calculator" tool for free from <http://www.suto-itec.com>.
- To fast access the tool download page, enter "flowrange" (without spaces) in the search field and click the search result.

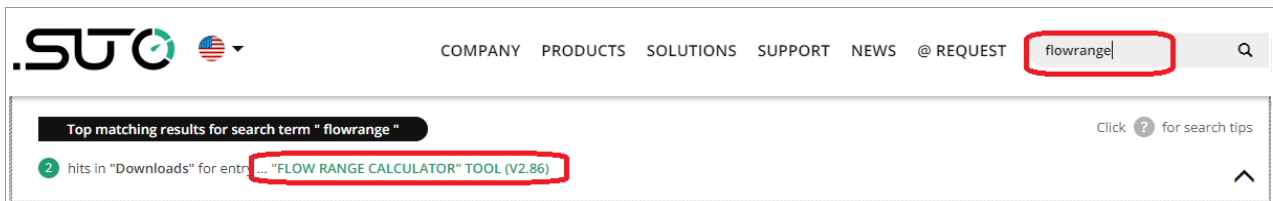

- The total consumption value is saved to the permanent memory every 5 minutes. If within these 5 minutes the device is powered off, it will restore the last consumption value which was saved in the last cycle.

6 Dimensional drawing

6.1 Thread type

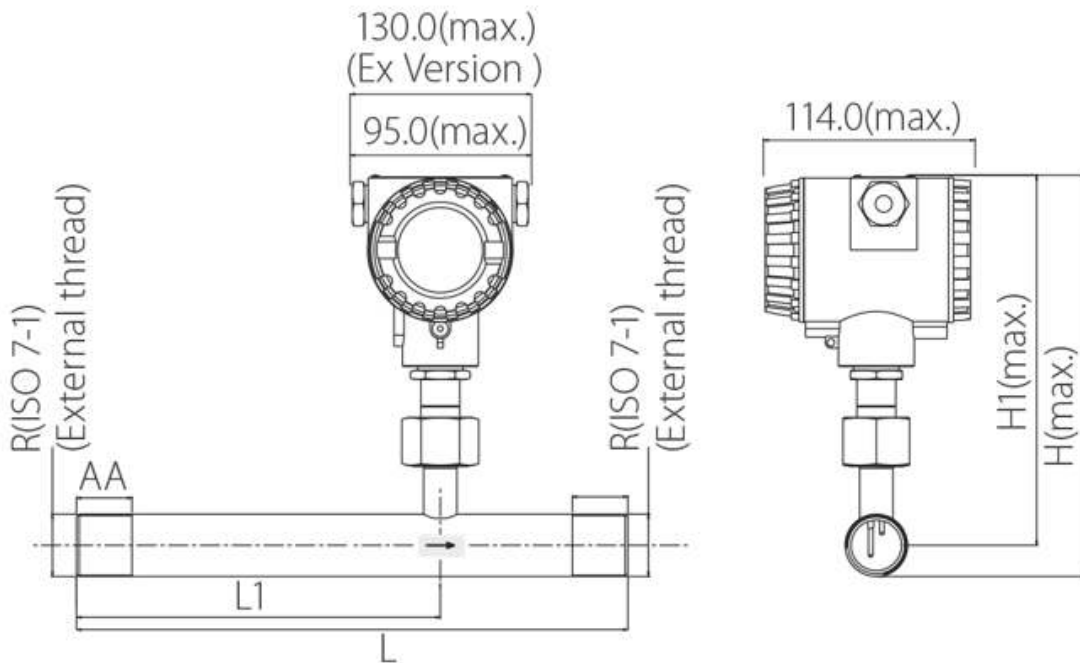

Unit: mm

Type	Pipe nominal size inch (DN)	L total length (mm)	L1 inlet length (mm)	H total height (mm)	H1 from pipe center to casing top (mm)	R External Thread
S452-1/2"	1/2"(DN15)	300	210	210.8	200.15	R 1/2"
S452-3/4"	3/4"(DN20)	475	275	213.6	200.15	R 3/4"
S452-1"	1" (DN25)	475	275	217	200.15	R 1"
S452-1¼"	1¼"(DN32)	475	275	221.35	200.15	R 1¼"
S452-1½"	1½"(DN40)	475	275	224.3	200.15	R 1½"
S452-2"	2" (DN50)	475	275	230.3	200.15	R 2"
S452-2½"	2½"(DN65)	475	275	246	208	R 2½ "
S452-3"	3" (DN80)	475	275	259	214.5	R 3"

6.2 Flange type

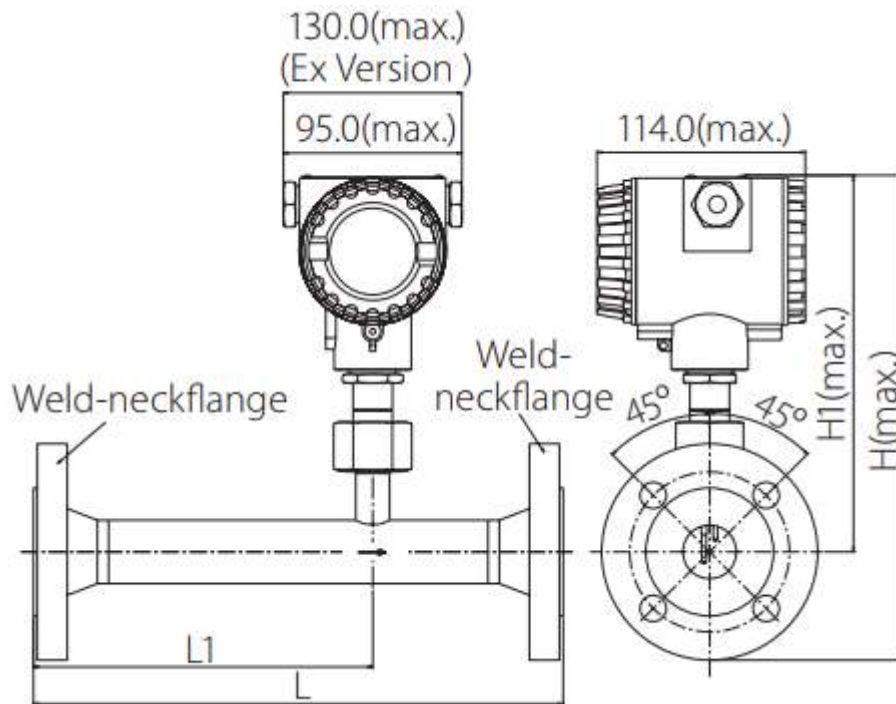

Unit: mm

Type	Pipe nominal size inch (DN)	L total length (mm)	L1 inlet length (mm)	H total height (mm)	H1 from pipe center to casing top (mm)	Flange (EN 1092-1 PN40)		
						$\varnothing D$ (mm)	$\varnothing K$ (mm)	$n \times \varnothing L$ (mm)
S452-1/2"	1/2"(DN15)	300	210	247.65	200.15	95	65	4x $\varnothing 14$
S452-3/4"	3/4"(DN20)	475	275	252.65	200.15	105	75	4x $\varnothing 14$
S452-1"	1" (DN25)	475	275	257.65	200.15	115	85	4x $\varnothing 14$
S452-1 1/4"	1 1/4"(DN32)	475	275	270.15	200.15	140	100	4x $\varnothing 18$
S452-1 1/2"	1 1/2"(DN40)	475	275	275.15	200.15	150	110	4x $\varnothing 18$
S452-2"	2" (DN50)	475	275	282.65	200.15	165	125	4x $\varnothing 18$
S452-2 1/2"	2 1/2"(DN65)	475	275	300.55	208	185	145	8x $\varnothing 18$
S452-3"	3" (DN80)	475	275	314.45	214.5	200	160	8x $\varnothing 18$

Type	Pipe nominal size inch (DN)	L total length (mm)	L1 inlet length (mm)	H total height (mm)	H1 from pipe center to casing top (mm)	Flange (ANSI/B16.5 Class 300)		
						ØD (mm)	ØK (mm)	n x ØL (mm)
S452-1/2"	1/2" (DN15)	300	210	247.65	200.15	95.2	66.5	4xØ15.7
S452-3/4"	3/4" (DN20)	475	275	258.85	200.15	117.3	82.5	4xØ19
S452-1"	1" (DN25)	475	275	262.15	200.15	123.9	88.9	4xØ19
S452-1¼"	1¼" (DN32)	475	275	266.85	200.15	133.3	98.5	4xØ19
S452-1½"	1½" (DN40)	475	275	277.85	200.15	155.4	114.3	4xØ22.3
S452-2"	2" (DN50)	475	275	282.75	200.15	165.1	127	4xØ19
S452-2½"	2½" (DN65)	475	275	303.35	208	190.5	149.3	8xØ22.3
S452-3"	3" (DN80)	475	275	317.25	214.5	209.5	168.1	8xØ22.3

7 Determining the installation point

To maintain the accuracy stated in the technical data, the flow meter must be inserted in the center of a straight pipe section with unhindered flow characteristics.

Unhindered flow characteristics are achieved if the section in front of the flow meter (inlet) and behind the flow meter (outlet) are sufficiently long, absolutely straight and free of obstructions such as edges, seams, curves and so on.

Please consider that enough space exists at your site for a adequate installation as described in this manual.



ATTENTION!

Wrong measurement is possible if the flow meter is not installed correctly.

- Pay attention to the design of the inlet and outlet section. Obstructions can cause counter-flow turbulence as well as turbulence in the direction of the flow.
- It is strongly recommended not to install S452 permanently in wet environment which exists usually right after a compressor outlet.

7.1 Additional inlet and outlet sections

The S452 with tube diameters from DN15 to DN25 already has the required inlet and outlet sections. No additional straight sections are needed.

For the S452 with diameters from DN32 to DN80, the S452 has a shortened inlet section and requires additional straight sections at the inlet and outlet. The additional length for the particular diameters are listed in the table below.

Flow obstructions before the measurement section	Additional length for DN32 [mm]		Additional length for DN40 [mm]		Additional length for DN50 [mm]		Additional length for DN65 [mm]		Additional length for DN80 [mm]	
	inlet	outlet	inlet	outlet	inlet	outlet	inlet	outlet	inlet	outlet
Slight curve (bend <90°C)	175	-	227.8	9.5	362.2	65.5	551.8	144.5	760.8	204.5
Reduction (Tube narrows towards measurement section)	265	-	353.5	9.5	521,5	65.5	758.5	144.5	938.5	204.5
Expansion (Tube expands towards measurement section)	265	-	353.5	9.5	521.5	65.5	758.5	144.5	938.5	204.5
90°C bend or T piece	265	-	353.5	9.5	521.5	65.5	758.5	144.5	938.5	204.5
2 x 90°C bends on one level	445	-	563	9.5	787	65.5	1103	144.5	1343	204.5
2 x 90°C bends 3 dimensional change of direction	985	-	1191.5	9.5	1583.5	65.5	2136.5	144.5	2556.5	204.5
Shut-off valve	1345	-	1610.5	9.5	2114.5	65.5	2825.5	144.5	3365.5	204,5

8 Installation

Before installing the flow meter, make sure that all components listed below are included in your package.

Qty	Description	Part no.
1	S452 Thermal Mass Flow Meter	S695 0452
1	Sealing ring	No P/N
1	Measuring section	A1301 ... A1306 (R thread) A1321 ... A1328 (Flange, EN-1092-1) A1341 ... A1348 (Flange, ANSI 16.5)
1	Bluetooth dongle	No P/N
1	Instruction manual	No P/N
1	Calibration certificate	No P/N

8.1 Install the S452

The S452 is shipped with the mounted measurement section. When installing the device, please make sure the following:

- The flow direction indicated on the S452 housing is consistent with the flow direction of the compressed air or gas.
- The gas flows from the inlet (long pipe section) to the outlet (short pipe section) as illustrated in the picture below.

Note: The S452 can be installed in any orientation (horizontal, vertical, side and upside-down). Please consider the needed straight inlet and outlet sections described in section 7.1 Additional inlet and outlet sections.

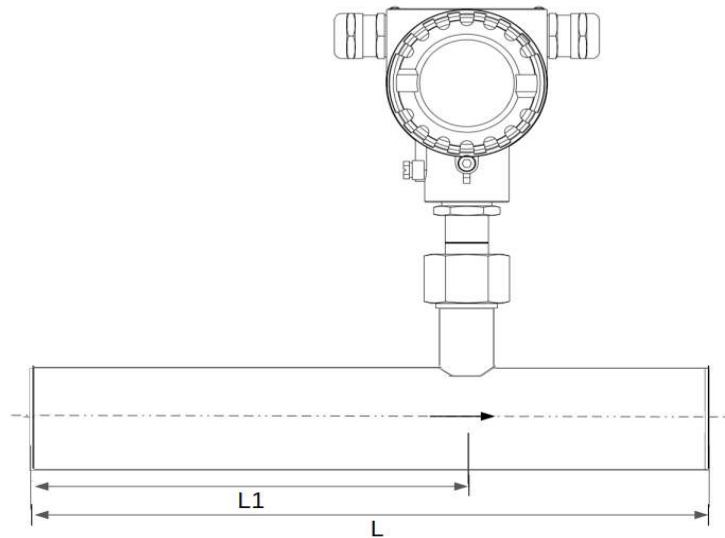

8.2 Remove the S452



ATTENTION!

Only remove the flow meter if the system is in a pressure-less condition.



1. Hold the S452.
2. Release the terminal nut at the connection thread.
3. Pull out the shaft slowly.
4. The measuring section can be closed with the optional closing cap so the system can work normally during maintenance.

8.3 Re-install after maintenance

- The re-installation of the measurement device is simple because the S452 fits into the pipe section only in one position.
- Make sure that the O-shaped sealing ring is installed.
- Tighten the terminal nut to secure the S452.

8.4 Electrical connection

When installing the cables please consider following points:

- Keep the stripped and twisted length of cable shield as short as possible.
- Screen and ground the signal lines.
- Unused cable entries must be closed with closers.
- Cable outer diameter should be between 6 and 8 mm.
- Single wire cross section area must be between 0.25 ... 0.75 mm².
- The thread size for the cable glands is M20 / 1.5.

8.4.1 Connection diagram

Remove the back cover from the S452, and the pin layout is shown below.

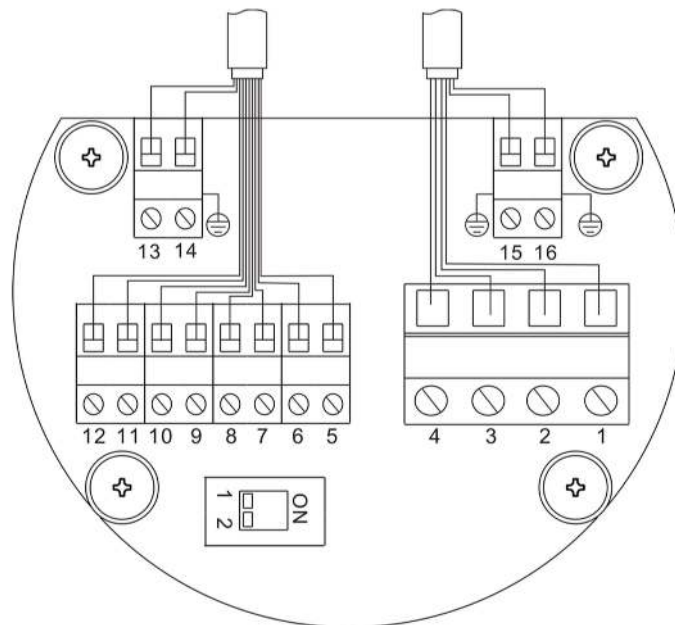

8.4.2 Pin assignment

The S452 provides four output options. The pin assignment of these options are given in the following table.

Pin	Output options			
	Pulse and analog	Modbus	M-Bus	HART
1	GND_{SDI}	GND_{SDI}	GND_{SDI}	GND_{SDI}
2	$+V_B$	$+V_B$	$+V_B$	$+V_B$
3	$-V_B$	$-V_B$	$-V_B$	$-V_B$
4	SDI	SDI	SDI	SDI
5	DIR	DIR	DIR	DIR
6	DIR	DIR	DIR	DIR
7	SW	SW	SW	NA
8	SW	SW	SW	NA
9	$-I_1$	$-I_1$	$-I_1$	$-I_1$ / -HART
10	$+I_1$	$+I_1$	$+I_1$	$+I_1$ / +HART
11	$-I_2$	+D	M1	NA
12	$+I_2$	-D	M2	NA
13	NA	GND_M	NA	NA
14	Earth	Earth	Earth	Earth
15	Earth	Earth	Earth	Earth
16	Earth	Earth	Earth	Earth

Legend to pin assignment

SDI	Digital signal (internal use)	SW	Isolated pulse output
GND_{SDI}	Ground for SDI	DIR	Flow direction input
$+V_B$	Positive supply voltage	D+	Modbus data+
$-V_B$	Negative supply voltage	D-	Modbus data -
$+I_1$	Positive signal output (analog 1)	M	M-Bus data
$-I_1$	Negative signal output (analog 1)	NA	Not applicable
$+I_2$	Positive signal output (analog 2)		
$-I_2$	Negative signal output (analog 2)		

9 Signal outputs

9.1 Analog and pulse outputs

If the S452 is purchased with the output option of analog and pulse signals, it provides 2 analog outputs and 1 pulse output. All signals are electrically isolated.

9.1.1 Analog output

The analog output can be used as an active output (current is sourced through the positive connection pin) or passive output. In the passive configuration a current signal is modulated into the external signal voltage.

Active	:	4 to 20mA, $R_L < 400 \Omega$
Passive	:	4 to 20mA, supply voltage 18... 30 VDC, $R_L < 500 \Omega$
For HART	:	$R_L \geq 250 \Omega$
Uncertainty	:	< 0.3 % of reading
Resolution	:	0.005 mA

9.1.2 Pulse output

No switch, no polarity required, galv. Isolate

Max. rating : 30 VDC, 200 mA

Pulse width : 10 ... 100 msec (depending on flow rate)

The maximum number of pulse per second is limited to 45 pulse per second. As a result depending on the flow rate and the selected consumption unit the maximum flow rate is limited to the values in the table below.

Pulse / consumption unit	Max flow		
	1/1	1/10	1/100
m ³ /h	162,000	1,620,000	16,200,000
m ³ /min	2,700	27,000	270,000
l/min	2,700	27,000	270,000
cfm	2,700	27,000	270,000
Kg/h	162,000	1,620,000	16,200,000
Kg/min	2,700	27,000	270,000
Kg/s	45	450	4,500
	Default	Configurable by service software	

Pulse connection diagram

Variant 1:

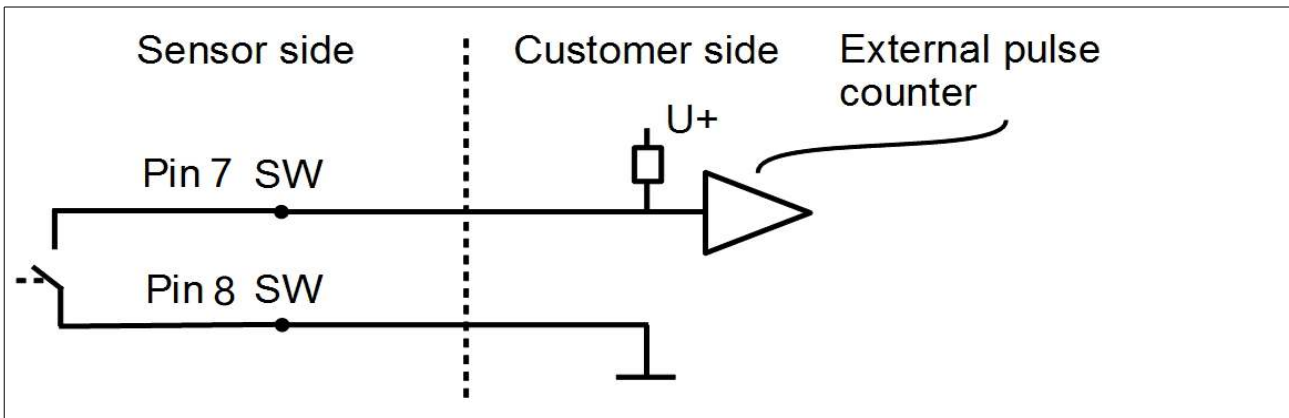

Variant 2:

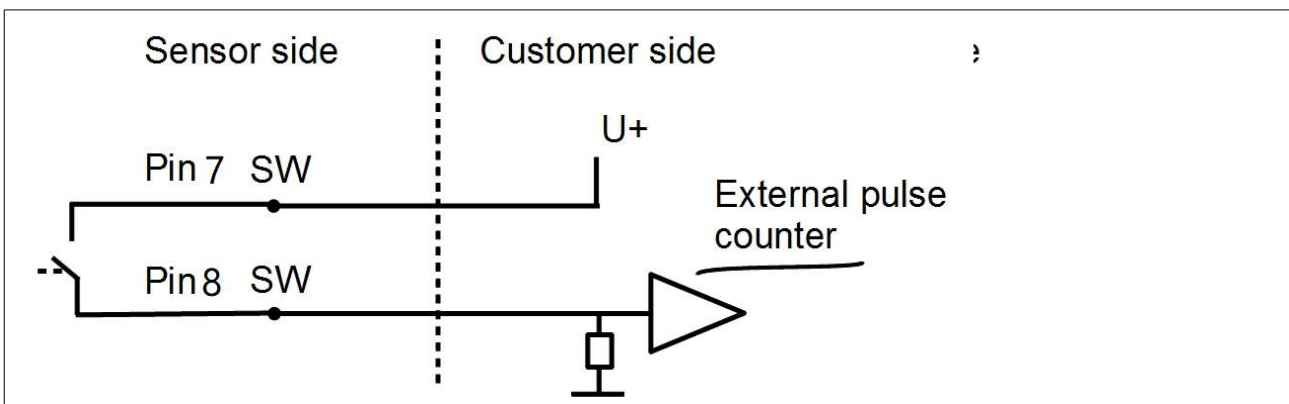

9.2 HART output

If the S452 is purchased with the output option of HART, the HART signal is modulated on analog output 1. In case S452 is used in a multi-drop configuration (more than 1 slave on the 4-20 mA line) the analog output cannot be used.

Device type	: Slave
Polling address	: 1 to 15 Bus address can be set through software
Physical interface	: BELL 202
Protocol version	: V 5.2
Tag	: S452
Tag description	: Flow meter
Frame/parity/Stop	: 8, 0, 1

9.3 Modbus Interface

If the S452 is purchased with the output option of Modbus, it provides one analog output and one pulse output.

The Modbus communication requires to activate terminal resistors at the last device on the bus system. If the S452 is the last device on the bus system, the DIP switches on the connector board should be set to "ON" position.

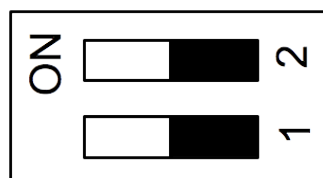

Termination resistor network switch

Device type	Slave
Address range	1 to 251 Bus address can be set through software
Physical interface	RS485 in accordance with EIA/TIA-485 standard
Baud rates	1200, 2400, 4800, 9600, 19200, 38400, 57600, 115200
Transm. mode	ASCII, RTU
Response time	Direct data access = 0 to 255 ms (can be configured)

The default Modbus communication settings are shown as below.

Mode	RTU
Baud rate	19200
Device address	Last two digits of serial number
Framing / parity / stop bit	8, N, 1
Response time	1 second
Response delay	0 ms
Inter-frame spacing	7 char

Response message that the device returns to the master:

- Function code: 03

The information for the byte order is shown in the table below:

Byte Order	Sequence				Data Type
	1st	2nd	3rd	4th	
1-0-3-2	Byte 1 (MMMMMMMM*)	Byte 0 (MMMMMMMM *)	Byte 3 (SEEEEEEE)	Byte 2 (EMMMMMMM *)	FLOAT
1-0-3-2	Byte 1	Byte 0 LSB	Byte 3 MSB	Byte 2	UINT32 INT32
1-0	Byte 1 MSB	Byte 0 LSB	---	---	UINT16 INT16
1-0	Byte 1 XXX *	Byte 0 DATA	---	---	UINT8 INT8

* S: Sign, E: Exponent, M: Mantissa, XXX: no value

Explanations of MSB and LSB

MSB MSB refers to Most Significant Byte first, which follows the Big-Endian byte order.

For example, if the main system follows the MSB first order:

When the 4-byte floating number, in the order of Byte1-Byte0-Byte3-Byte2, is received from the slave (sensor), the master must change the byte order to Byte3-Byte2-Byte1-Byte0 for the correct display of the value.

LSB LSB refers to Least Significant Byte first, which follows the Little-Endian byte order.

For example, if the main system follows the LSB first order:

When the 4-byte floating number, in the order of Byte1-Byte0-Byte3-Byte2, is received from the slave (sensor), the master must change the byte order to Byte0-Byte1-Byte2-Byte3 for the correct display of the value.

Remarks: Modbus communication settings as well as other settings can be changed by the service App **S4C-FS** or through the windows based **Service Software**.

Available measurement channels:

Channel description	Unit	Resolution	Format	Length	Modbus register address
Velocity	m/s	0.1	FLOAT	4-Byte	0
Flow	m ³ /h	0.1	FLOAT	4-Byte	6
Consumption	m ³	1	UNIT32	4-Byte	12
Reverse consumption	m ³	1	UNIT32	4-Byte	18
Medium temperature	°C	0.1	FLOAT	4-Byte	24
Ambient temperature	°C	0.1	FLOAT	4-Byte	36

9.4 M-Bus output

If the S452 is purchased with the output option of M-Bus, it provides one analog output and one pulse output besides the M-bus output.

Device type : **Slave**
Address range : 1 ... 251
 Bus address can be set through software
Physical interface : Meter-Bus, EN1434-3
Baudrates : 300, 2400, 9600
Frame/parity/Stop : 8, E, 1

9.5 Connection between S452 Outputs and Customer Equipment

This section provides figures to show how outputs supported by the S452 connect with the customer equipment.

In the following figures, the **SUTO Instrument** indicates the S452.

Analog output (Isolated)

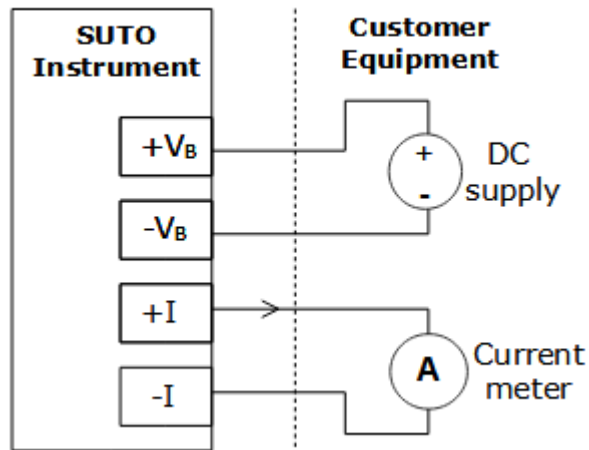

Pulse output (passive)

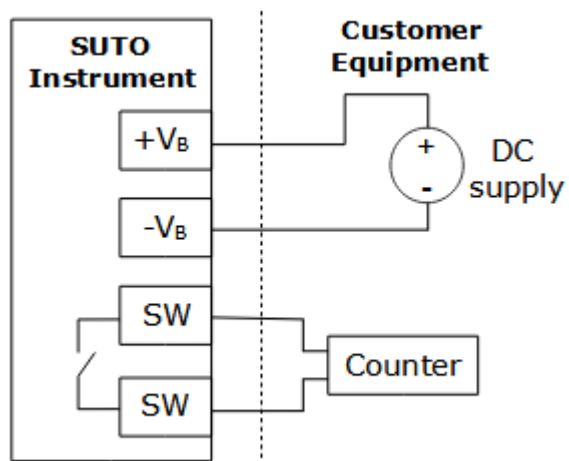

Modbus/RTU output

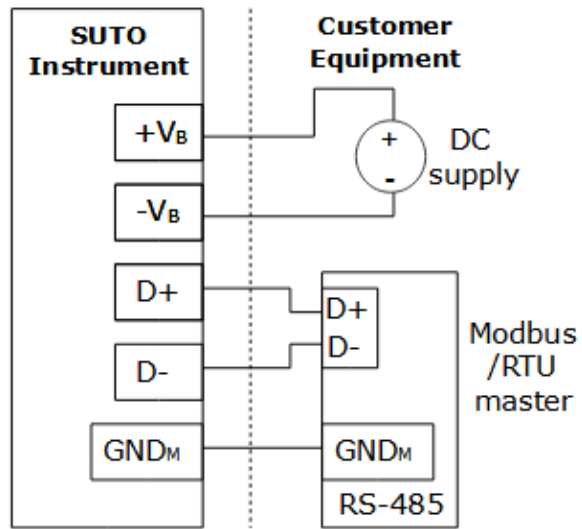

M-Bus output

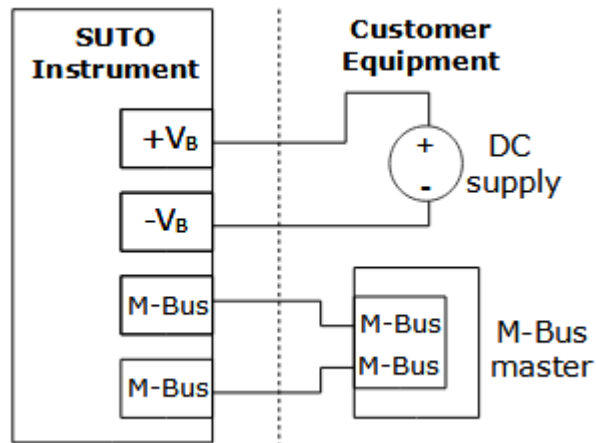

HART output

Active HART output

Note: The active HART output can only support one HART slave.

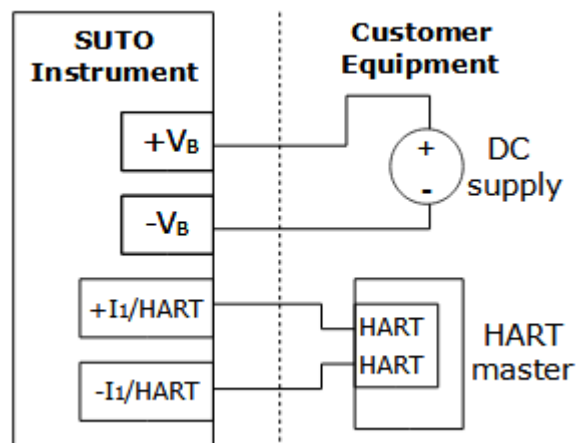

Passive HART output

Note: If you want to connect multiple slaves on the bus (multidrop), use the passive solution.

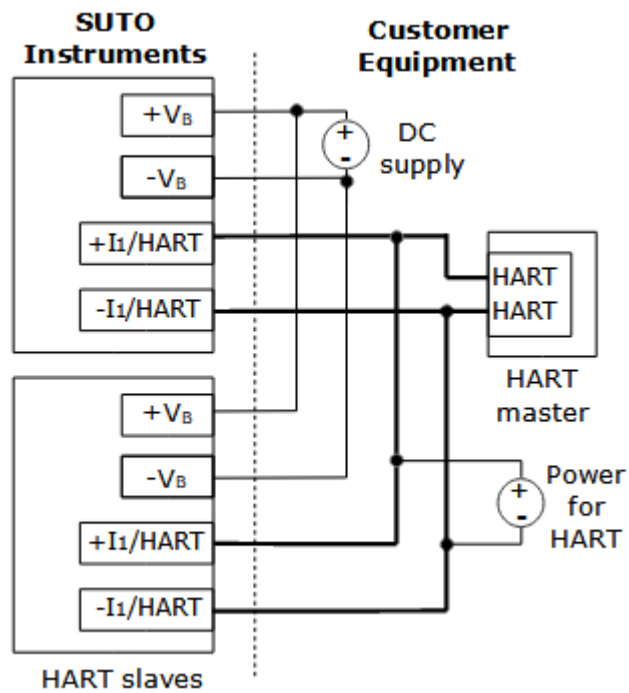

10 Information on the Display

When the S452 comes with a display, startup information, measuring values, and more can be viewed on the display.

10.1 Startup

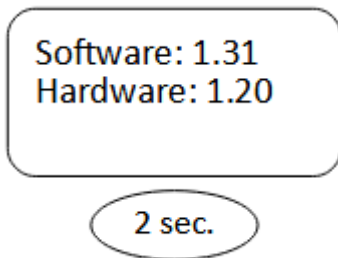
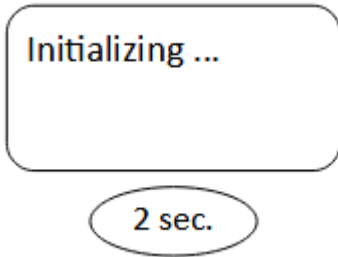

Software and hardware versions

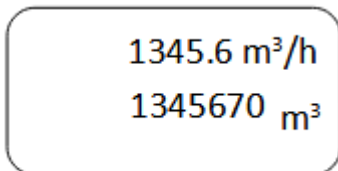

Online measuring values: flow and consumption. After resetting, the S452 has a warm-up time of about 20 seconds. During the period, the flow is zero.

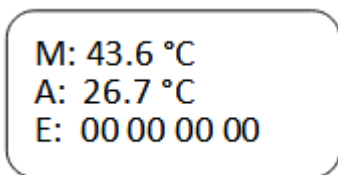

Medium, ambient temperature, and error code, which are shown every 5 seconds.

10.2 Data and Signs

This section explains data and signs on the display when the S452 goes into a normal working state.

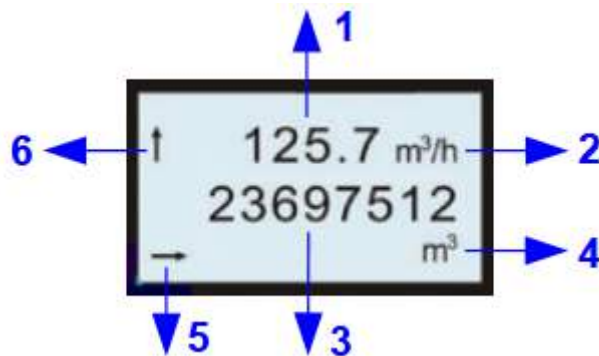

- | | |
|---|--|
| 1 | Flow value, 6 digits |
| 2 | Flow unit |
| 3 | Consumption value, 10 digit |
| 4 | Consumption unit |
| 5 | Flow direction sign. <ul style="list-style-type: none"> • →: default flow direction • ←: reverse flow direction |
| 6 | Alarm sign. <ul style="list-style-type: none"> • No sign: indicates no alarm. • ↑: indicates an alarm was raised. • ↓: indicates the overflow alarm was raised. |

11 Configuration

The S452 enables you to configure parameter settings according to on-site requirements.

The following table gives an overview about the available settings.

Parameters	Available settings	Default
Measurement	Tube diameter	According to the ordered section
	Flow unit	m ³ /h
	Consumption unit	m ³
	Reference conditions	P _s = 1000 hPa; T _s = 20°C
	Gas type selection	Air
	Consumption counter	0 m ³
	Operation pressure	0.6 MPa
	Flow direction	Standard
Analogue output 1	Measurement channel	Flow
	Scaling	4 mA: 0 m ³ /h 20 mA: max flow
	Active / passive	Active
Analogue output 2	Measurement channel	Medium Temperature
	Scaling	4 mA: -50°C 20 mA: 200°C
	Active / passive	Active
Pulse output	Pulse / Alarm	Pulse
	Pulses per consumption unit	1
HART	Fieldbus address	0
	Manufacturer ID	255
	Device type code	0
Modbus	Device address	1
	Baudrate	19200
	Framing/parity/Stop bit	8, N, 1
	Transmission mode	RTU
M-Bus	Address	0
	Manufacturer code	END
	Baudrate	300
	Access number	0

To configure the S452 settings, use the service software, which can be downloaded on the SUTO website.

1. Install the S452 service software on your Windows® PC as steps below:
 - a. Access www.suto-itec.com/en/downloads/#, and input "S450" as key word to get the service software, as below:

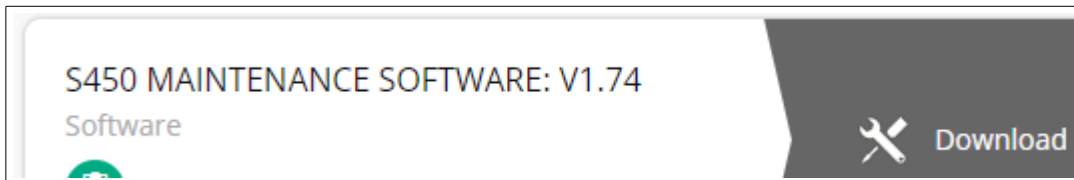

- b. Download the software and unzip it on your PC.
 - c. Run *Service Software S450 V1.74.exe* to install the software.
2. Power up the S452.
3. If the PC does not provide the Bluetooth interface, insert the USB Bluetooth dongle provided in the delivery package to the PC.
4. Pair the Bluetooth of the PC and the S452. For details, see *S450/S452 USB stick and Bluetooth Dongle IM*.
5. On the PC, run the service software and follow the onscreen instructions configure the S452. You can also refer to the online help file for more information.

Remarks:

To enable a stable Bluetooth connection, ensure the following:

- The distance between S452 and PC is not more than 5 meters.
- The PC Bluetooth antenna points roughly towards the direction of the display (front part).

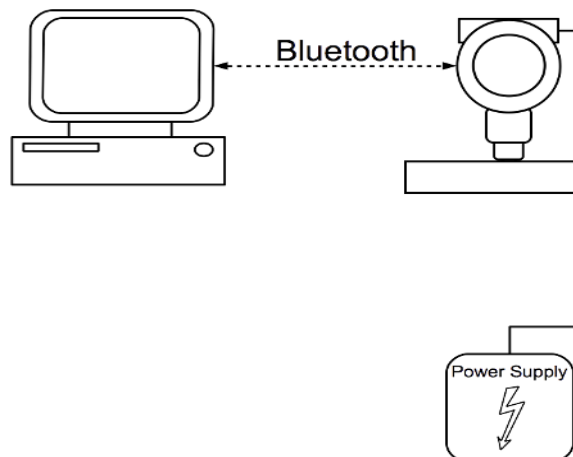

12 Optional accessories

12.1 Display

The S452 display shows the values of velocity, flow rate, consumption and error messages.

12.2 Service kit

The service kit is designed to enable the wired communication between the PC and an S452.

The diagram below shows the cable connection between an S452 and a PC through the service kit. Please ensure that S452 or the service kit is connected with the power supply because the USB port cannot provide enough power to both of them.

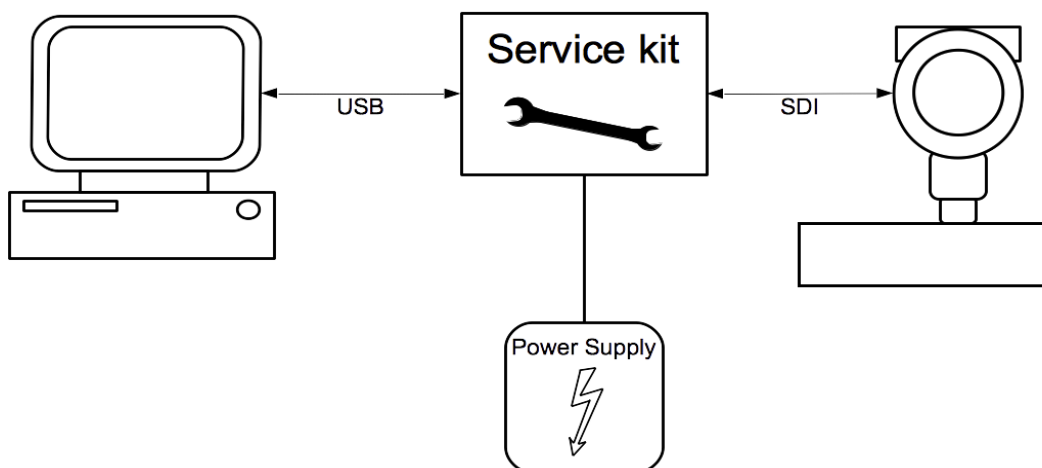

13 Calibration

The flow meter is calibrated ex work. The exact calibration date is printed on the certificate which is supplied together with the flow meter. The accuracy of the flow meter is regulated by the on-site conditions, and parameters like oil, high humidity or other impurities can affect the calibration and furthermore the accuracy. However, we recommend you calibrate the instrument at least once per year. The calibration is excluded from the instruments warranty. For the calibration service, please contact the manufacturer.

14 Maintenance

To clean the flow meter, it is recommended to use distilled water or isopropyl alcohol only.



ATTENTION!

Do not touch the surface of the flow meter plate.

Avoid mechanical impact on the flow meter (e.g with a sponge or a brush).

If the contamination can not be removed, you must have the flow meter inspected and maintained by the manufacturer.

15 Disposal or waste



Electronic devices are recyclable material and do not belong in the household waste.

The device, the accessories and its packings must be disposed according to your local statutory requirements.

The dispose can also be carried by the manufacturer of the product. Please contact the manufacturer for details.

SUTO iTEC GmbH

Grißheimer Weg 21
D-79423 Heitersheim
Germany

Tel: +49 (0) 7634 50488 00
Email: sales@suto-itec.com
Website: www.suto-itec.com

SUTO iTEC (ASIA) Co., Ltd.

Room 10, 6/F, Block B, Cambridge Plaza
188 San Wan Road, Sheung Shui, N.T.
Hong Kong

Tel: +852 2328 9782
Email: sales.asia@suto-itec.com
Website: www.suto-itec.com

SUTO iTEC Inc.

5460 33rd St SE
Grand Rapids, MI 49512
USA

Tel: +1 (616) 800-7886
Email: sales.us@suto-itec.com
Website: www.suto-itec.com

All rights reserved ©

Modifications and errors reserved

S452_im_en_2023-3