

## Instruction and Operation Manual

# S220 OEM

## Dew Point Transmitter with G1/2" connection



Revision: 2024-1-1  
Modified: March, 2024

Dear Customer,

Thank you for choosing our product.

The operating instructions must be read in full and carefully observed before starting up the device. The manufacturer cannot be held liable for any damage which occurs as a result of non-observance or non-compliance with this manual.

Should the device be tampered with in any manner other than a procedure which is described and specified in the manual, the warranty is cancelled and the manufacturer is exempt from liability.

The device is destined exclusively for the described application.

SUTO offers no guarantee for the suitability for any other purpose. SUTO is also not liable for consequential damage resulting from the delivery, capability or use of this device.

## Table of contents

1 Safety Instructions.....	4
2 Registered Trademarks.....	6
3 Application.....	7
4 Features.....	7
5 Technical Data.....	8
5.1 General.....	8
5.2 Electrical Data.....	9
5.3 Output Signals.....	9
5.4 Accuracy .....	9
6 Dimensional Drawing.....	10
7 Installation .....	11
7.1 Installation Requirements.....	12
7.2 Installation Procedure .....	13
7.2.1 Install with Measuring Chamber A699 3491.....	13
7.2.2 Install with By-pass Measuring Chamber A699 3493.....	14
7.2.3 Install without Measuring Chamber.....	16
7.3 Remove the Dew Point Transmitter.....	17
7.4 Electrical Connection .....	17
7.5 Connection between S220 and Customer Equipment.....	19
8 Display (Option).....	20
8.1 Display Information.....	20
8.2 Displayed Values.....	20
8.3 Display Rotation.....	20
9 Signal Outputs.....	21
9.1 Analog Output .....	21
9.2 Modbus/RTU Output .....	21
9.2.1 Modbus Information.....	21
9.2.2 Holding Register Table for Modbus/RTU .....	23
10 Optional Accessories.....	26
10.1 Measuring Chambers .....	26
10.2 Service Kit.....	26
11 Calibration.....	27
12 Maintenance.....	27
13 Disposal or Waste.....	27

## 1 Safety Instructions

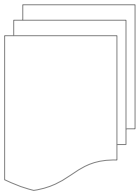

**Please check if this instruction manual matches with the product type.**

Please observe all notes and instructions indicated in this manual. It contains essential information which must be observed before and during installation, operation and maintenance. Therefore this instruction manual must be read carefully by the technician as well as by the responsible user or qualified personnel.

This instruction manual must be available at the operation site of the Dew Point Sensor at any time. In case of any obscurities or questions, regarding this manual or the product, please contact the manufacturer.



### **WARNING!**

#### **Compressed air!**

**Any contact with quickly escaping air or bursting parts of the compressed air system can lead to serious injuries or even death!**

- Do not exceed the maximum permitted pressure range (see sensors label).
- Only use pressure tight installation material.
- Avoid that persons get hit escaping air or bursting parts of the instrument.
- The system must be pressure-less during maintenance work.



### **WARNING!**

#### **Voltage used for supply!**

**Any contact with energized parts of the product, may lead to a electrical shock which can lead to serious injuries or even death!**

- Consider all regulations for electrical installations.
- The system must be disconnected from any power supply during maintenance work.
- Any electrical work on the system is only allowed by authorized qualified personal.



**ATTENTION!**

**Permitted operating parameters!**

**Observe the permitted operating parameters, any operation exceeding this parameters can lead to malfunctions and may lead to damage on the instrument or the system.**

- Do not exceed the permitted operating parameters.
- Make sure the product is operated in its permitted limitations.
- Do not exceed or undercut the permitted storage and operation temperature and pressure.

**General safety instructions**

- It is not allowed to use the product in explosive areas.
- Please observe the national regulations before/during installation and operation.

**Remarks**

- It is not allowed to disassemble the product.
- Always use spanner to mount the product properly.



**ATTENTION!**

**Measurement values can be affected by malfunction!**

**The product must be installed properly and frequently maintained, otherwise it may lead to wrong measurement values, which can lead to wrong results.**

## **Storage and transportation**

- Make sure that the transportation temperature of the device is between -30 ... +70°C.
- For transportation it is recommended to use the packaging which comes with the device.
- Please make sure that the storage temperature of the device is between -20 ... +50°C.
- Avoid direct UV and solar radiation during storage.
- For the storage the humidity must be <95% rH, no condensation.

## **2 Registered Trademarks**

SUTO®

Registered trademark of SUTO iTEC

MODBUS®

Registered trademark of the Modbus Organization, Hopkinton, USA

### 3 Application

The S220 OEM Dew Point Transmitter is an industrial instrument designed for measuring dew point and related parameters in compressed air or industrial gases under specified operating conditions (See next page ).

Parameter	Default unit
Temperature	°C
Humidity	% rH
Dew point	°C Td
Pressure (optional)	bar (g)

**Remark:** You can change the units using the service kit (optional) or the S4C-DP mobile App.

The S220 OEM Dew Point Transmitter is mainly used in compressed air systems in the industrial environment, and not developed to be used in explosive areas. To use it in explosive areas, please contact the manufacturer.

### 4 Features

- The S220 OEM Dew Point Transmitter is applicable for measuring down to -100°C Td.
- Optional display for on-site values. The display can be rotated 340° horizontally to ease your access to readings.
- Various signal output options: 4 ... 20 mA 2-wire, 4 ... 20 mA 3-wire, or 4 ... 20 mA 3-wire + Modbus RTU.
- Optional integrated pressure sensor.
- IP65 casing provides robust protection in rough industrial environment.
- Very fast response time ensures safe and reliable indication whenever dew points are out of valid ranges.
- High accuracy of  $\pm 2^\circ\text{C}$  Td dew point.

## 5 Technical Data

### 5.1 General

<b>CE</b>	
Parameters	Standard unit dew point: °C Td Standard unit temperature: °C other units: °F, K Standard unit humidity: % rH Standard unit pressure: bar (g)
Principle of measurement	Capacitive method and frequency method
Measuring range	Dew point : -100 ... +20°C Td Relative Humidity : 0 ... 90% rH Temperature : -30 ... +70°C Pressure (option) : 0 ... 1.6 MPa
Sensor	Dew point sensor: QCM + Polymer Temperature sensor: Pt100 Pressure sensor: Piezo resistive type
Measuring medium	Air, Argon, O <sub>2</sub> , N <sub>2</sub> , CO <sub>2</sub>
Response time (T <sub>90</sub> ) @4 l/min	0 °C Td → -80 °C Td ≤ 420 sec -80 °C Td → 0 °C Td ≤ 90 sec
Ambient temperature	0 ... +50°C
Ambient humidity	0 ... 95% rH
Operating pressure	-0.1 ... 1.6 MPa
Casing material	Casing: Aluminium alloy Process thread: Stainless steel 1.4301 (SUS 304) Display cover: PC + ABS
Protection class	IP65
Display (optional)	0.66" OLED display for displaying the measured value and unit 340° horizontally rotatable*
Dimensions	See dimensional drawing on the page <a href="#">10</a>
Screwing thread	G ½" thread (ISO 228/1)
Weight	180 g



\* The rotation force cannot exceed 3.0 N.m

## 5.2 Electrical Data

Power supply	15 ... 30 VDC
Current consumption	2-wire: 4 ... 20 mA 3-wire: 40 mA @ 24 VDC 3-wire with display: 50 mA @ 24 VDC

## 5.3 Output Signals

Analog output	4 ... 20 mA 3-wire or 4 ... 20 mA 2-wire
Analog output scaling	4 mA = -100°C Td 20 mA = +20°C Td
Modbus output	Modbus/RTU
Modbus communication	Mode: RTU Baud rate: 19200 Device address: last 2 digits of serial number Framing / parity / stop bit: 8 / N / 1 Response time: 1 second Response delay: 0 ms Interframe spacing: 7 char

## 5.4 Accuracy

Accuracy	Dew point: ±1 °C Td (0 ... 20°C Td) ±2 °C Td (-70 ... 0°C Td) ±3 °C Td (-100 ... -70°C Td)  Temperature: ± 0.3°C  Pressure: 0.5% FS
Repeatability of dew point	± 0.5°C
Stated accuracy at	Ambient/process temperature 23°C ± 3°C Ambient/process humidity <95% rH, no condensation Airflow > 2 l/min at sensor tip

### 6 Dimensional Drawing

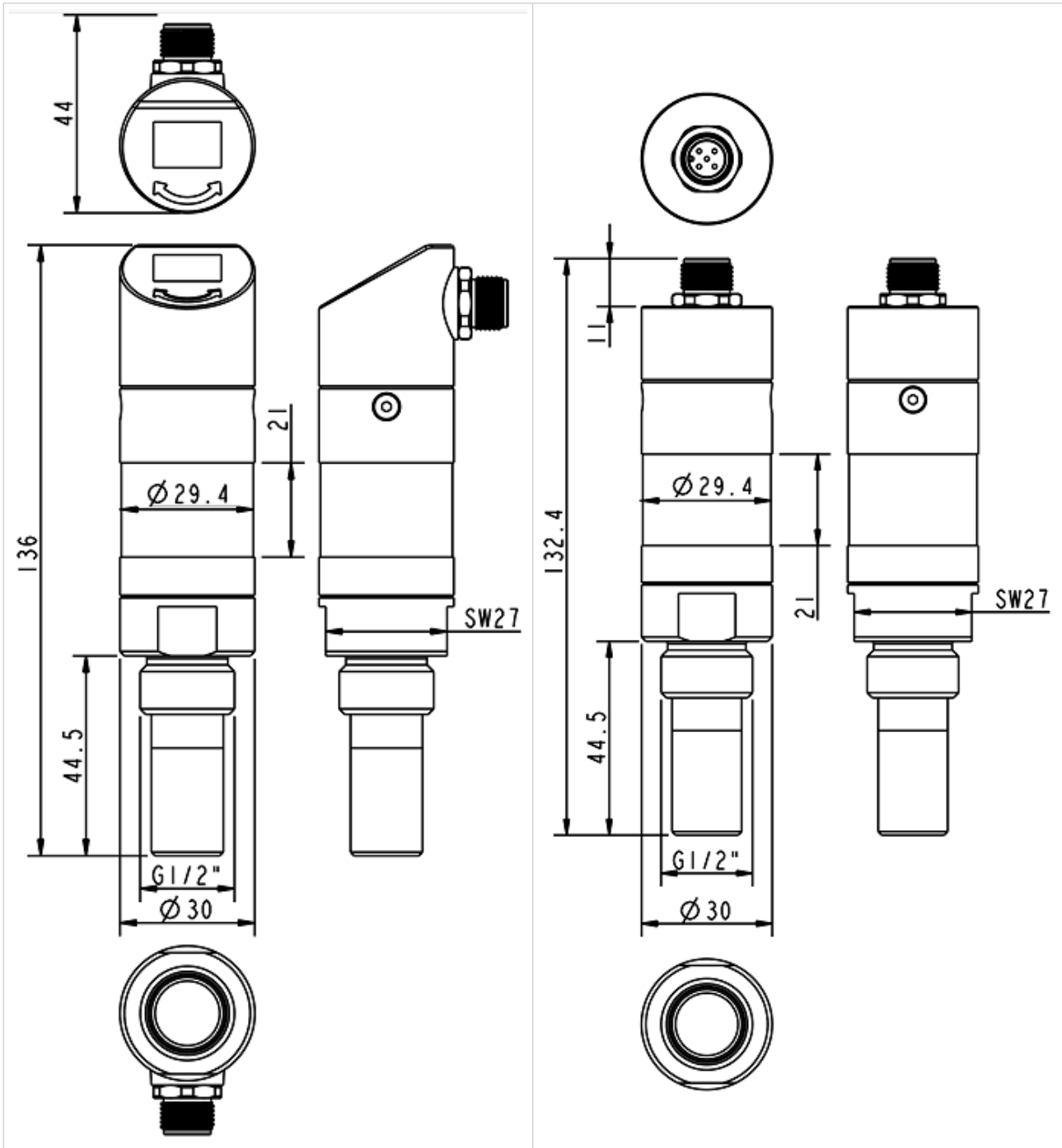

## 7 Installation

Before installing the S220, please make sure that all components listed below are included in your package.

Qty	Description	Order No. (Version dependent)
1	S220 OEM Dew Point Transmitter	S699 2201 S699 2202 S699 2203 S699 2207
1	Depending on orders: M12 plug or M12 cable	Plug: C219 0059 Cable: A553 0104/A553 0105
1	Instruction manual	No P/N
1	Calibration certificate	No P/N

The S220 OEM Dew Point Transmitter is offered in different versions. Depending on the version the options might be different, see below table for an overview about the different versions, their signal outputs and available options.

### S220 OEM Dew Point Transmitter versions

Order No.	Version
S699 2201	S220 OEM Dew Point Transmitter with 2-wire analog and SDI output
S699 2202	S220 OEM Dew Point Transmitter with 3-wire analog and SDI output
S699 2203	S220 OEM Dew Point and Pressure Transmitter with 3-wire analog and Modbus/RTU output
S699 2207	S220 OEM Dew Point Transmitter with 3-wire analog and Modbus/RTU output

### Display options

Order No.	Code	Description
	A	Without display
A1386	B	OLED Display option for S220 OEM 3-wire Analog and Modbus version (only for S699 2203)

In any case, if you need support to choose the right version for your application, please feel free to contact SUTO sales support.

## 7.1 Installation Requirements

- The device is for indoor use only! At an outdoor installation, it must be protected from solar radiation and rain.
- It is strongly recommend not to install the S220 permanently in a wet environment, which usually exists right after a compressor outlet.
- The flowing air or gas must pass the sensor tip for a proper measurement. This can be realized with a measurement chamber. For an installation without the measuring chamber, you must insert the device to the required depth, as described in section [7.2.3 Install without Measuring Chamber](#).
- Sensor orientation requirement

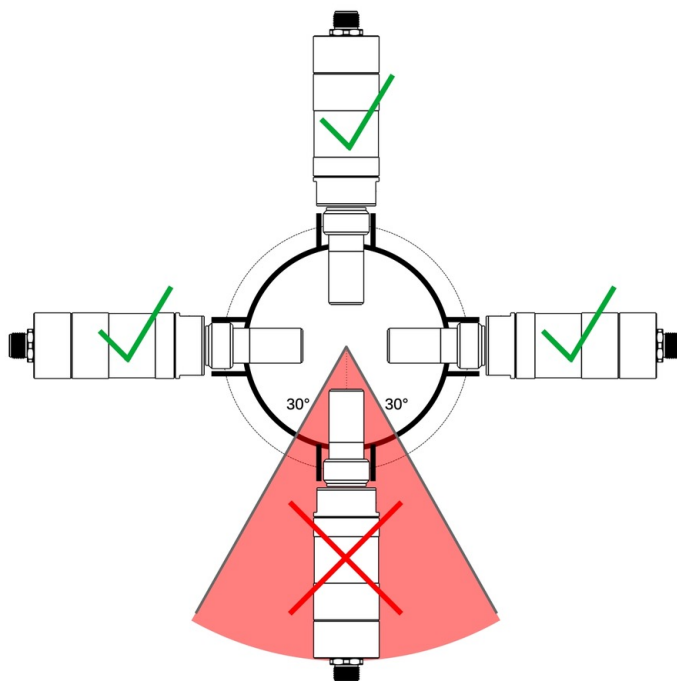

Install the device only in the recommended area, as shown in picture on the left.

The angle between the device and the centre vertical line of the tube must be greater than  $30^\circ$ .

An upside down installation is not permitted.



### ATTENTION!

**Wrong measurement is possible if the instrument is not installed correctly.**

## 7.2 Installation Procedure

### 7.2.1 Install with Measuring Chamber A699 3491

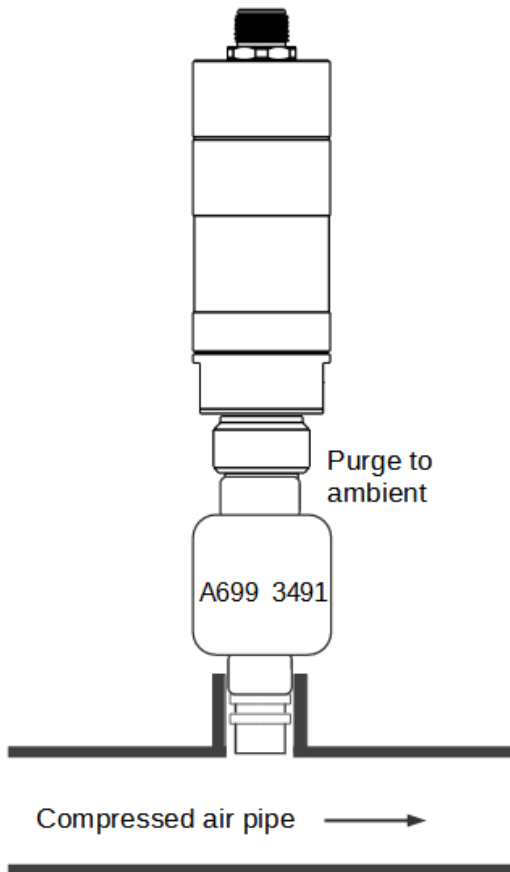

1. Mount the transmitter on the measuring chamber by using the G1/2" connection.
2. Make sure the transmitter is tightly sealed, therefore the sealing ring on the transmitter must be used.
3. Connect the measuring chamber to the compressed air system using a quick connector. Make sure the Dew Point Transmitter is screwed on the chamber before connecting. The measuring chamber will create a purge flow.

### 7.2.2 Install with By-pass Measuring Chamber A699 3493

For the model A699 3493, there are two installation methods:

#### **Method 1: Full pass through by-pass installation**

This method is to be used when the full air flow is passing through the measuring chamber.

1. Connect the inlet of the chamber using a 6 mm teflon hose to your system.

**Note:** The full flow must pass the measuring chamber. Ensure a certain flow rate to get fast response time.

2. Connect the outlet of the chamber to your system using the 6 mm hose quick connector.

See figure below for details.

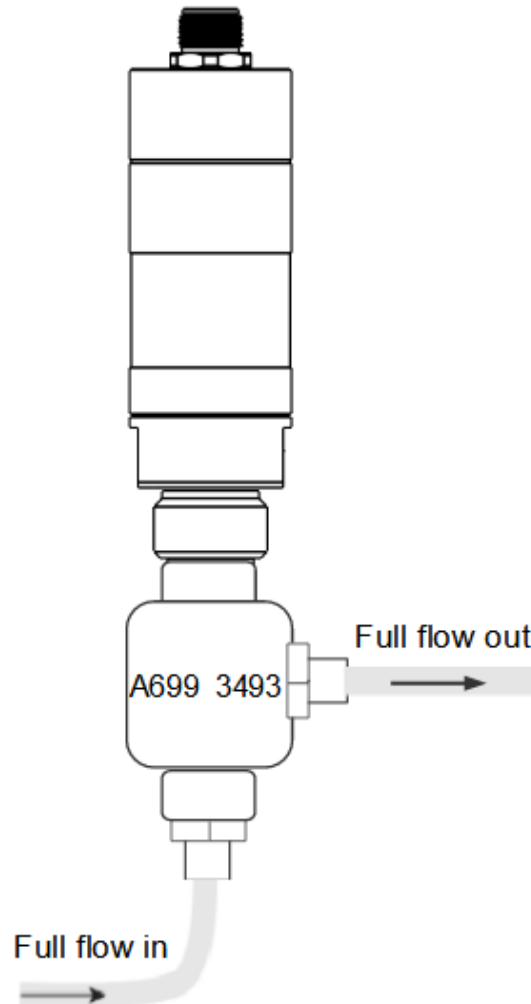

**Method 2: By-pass installation**

**Note:** In order to use the measurement chamber in a by-pass you must ensure a pressure difference between P1 and P2 as indicated in the picture below.

1. Connect the inlet of the chamber to your pipe system.
2. Connect the outlet of the chamber to your pipe system where the pressure is known to be lower than the inlet pressure.

**Note:** The pressure difference  $P1 > P2$  is needed to create a by-pass flow through the chamber. If there is no pressure difference between P1 and P2, there will be no flow through the chamber and therefore the response time will be very slow or the device will not even respond at all to the dew point changes.

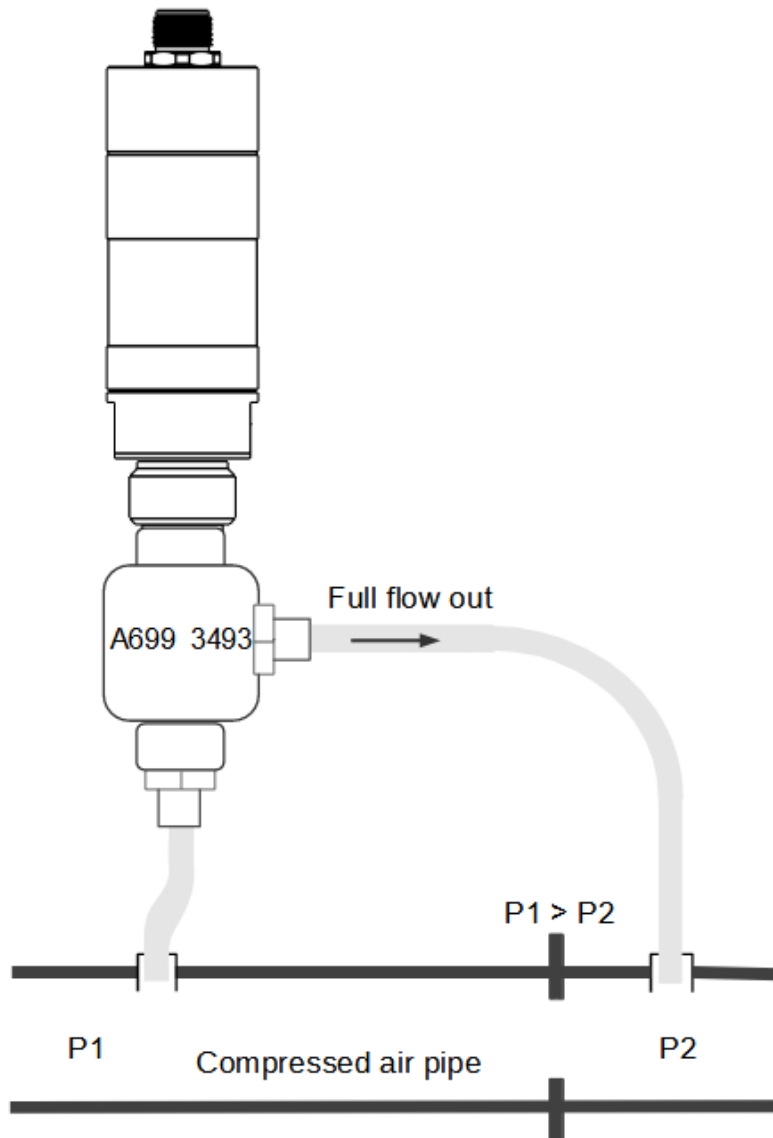

### 7.2.3 Install without Measuring Chamber

This is the full flow installation. The sensor is in the pipe.

#### Method 1: Install through a nozzle

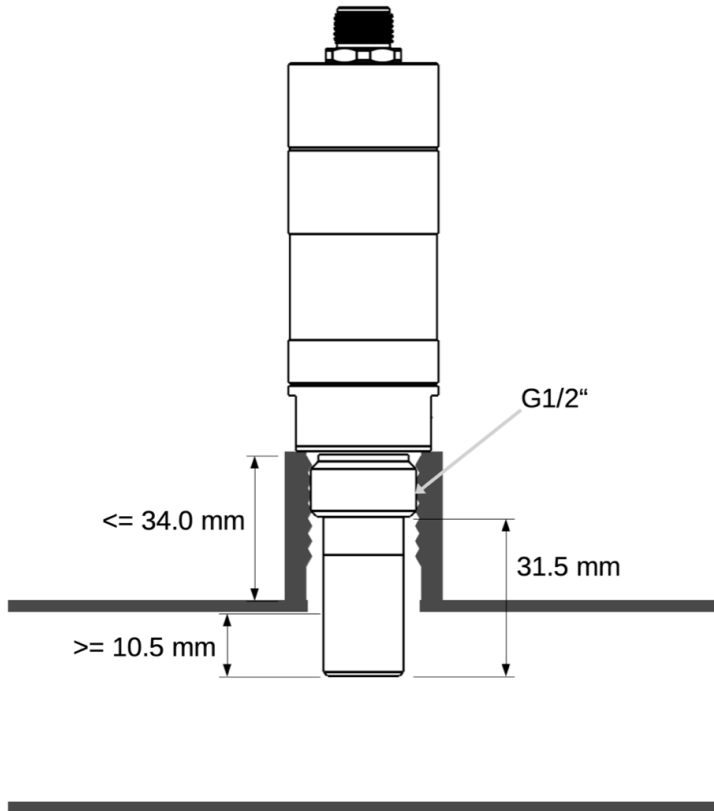

- Install the device only if the system is pressure-less.
- Check the size of the nozzle and make sure that no less than 1/3 of the sensor tip is inside of the pipe.
- The inner thread of the nozzle must be G 1/2".



### Method 2: Install with NPT thread adapter

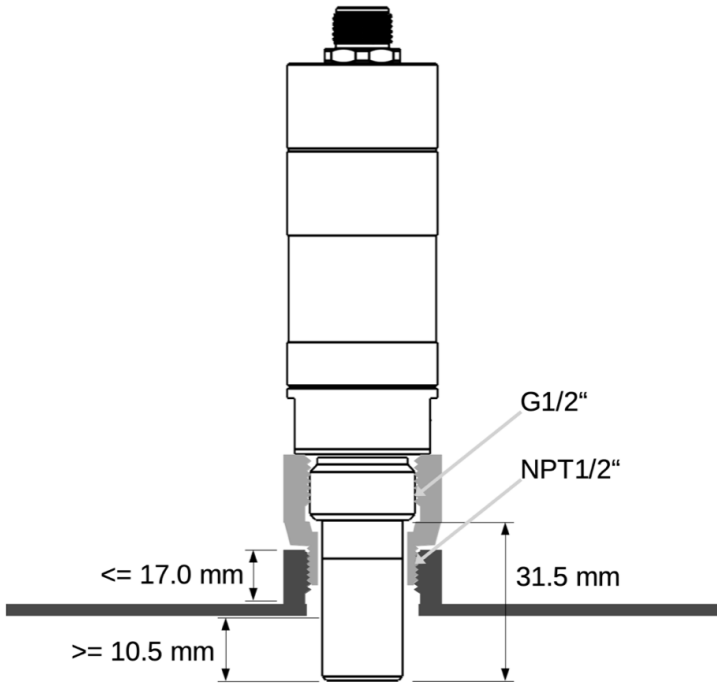

- Install the device only if the system is pressure-less.
- Please check the size of the nozzle and make sure not less than 1/3 of the sensor tip is inside of the pipe.
- The thread adapter (C190 0534) is used to adapt from G 1/2" sensor side to NPT 1/2" process connection.

### 7.3 Remove the Dew Point Transmitter

Unscrew the device off the measurement chamber or from the nozzle. Please make sure that the system is pressure-less before the Dew Point Transmitter is removed.

### 7.4 Electrical Connection

#### Connection pins of the M12 plug

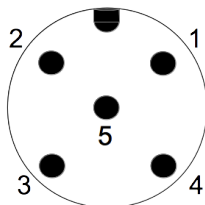

Connection pins  
(View onto the connector)

**Pin assignment of the M12 plug**

**Dew Point Transmitter version:** S699 2201

**Output signal:** 2-wire Analog output and SDI

Pin 1	Pin 2	Pin 3	Pin 4	Pin 5
SDI	$-V_B$ (Analog loop)	$+V_B$ (Analog loop)	N/A	N/A
Brown	White	Blue	Black	Gray

**Dew Point Transmitter version:** S699 2202

**Output signal:** 3-wire Analog output and SDI

Pin 1	Pin 2	Pin 3	Pin 4	Pin 5
SDI	$-V_B$	$+V_B$	$+I$ 4 ... 20 mA	NA
Brown	White	Blue	Black	Grey

**Dew Point Transmitter version:** S699 2203/S699 2207

**Output signal:** 3-wire Analog output and Modbus/RTU

Pin 1	Pin 2	Pin 3	Pin 4	Pin 5
$+I$ 4 ... 20 mA	$-V_B$	$+V_B$	D+ Modbus/RTU	D- Modbus/RTU
Brown	White	Blue	Black	Grey

**Legend to pin assignment**

SDI Digital signal (internal use)

$-V_B$  Negative supply voltage

$+V_B$  Positive supply voltage

$+I$  Active 4 ... 20 mA signal

NA Not applicable

D+ Modbus/RTU data +

D- Modbus/RTU data -



**ATTENTION!**

**Do not screw the M12 plug using force. Otherwise, it may damage the connecting pins.**

## 7.5 Connection between S220 and Customer Equipment

The figures below show how the S220 outputs connect with the customer equipment.

2-wire analog output

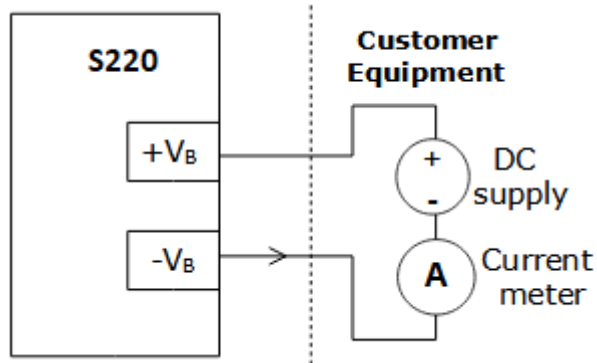

3-wire analog output

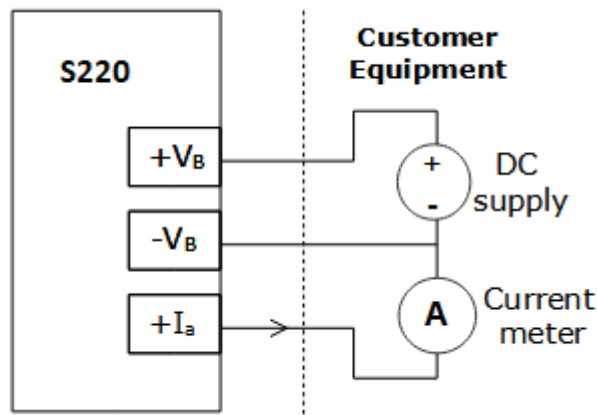

3-wire analog and Modbus/RTU outputs

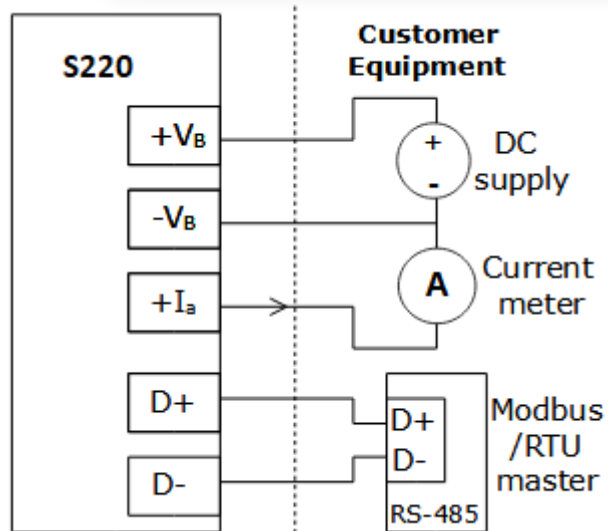

Modbus/RTU output

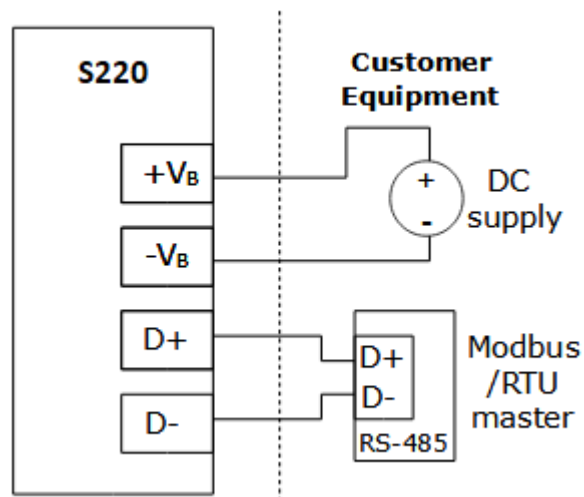

## 8 Display (Option)

### 8.1 Display Information

The dew point transmitter S220 can be equipped with an optional display directly mounted on the sensor. The display shows the live values of Dew point, Temperature, Humidity and Pressure (if the dew point transmitter with a pressure sensor).

### 8.2 Displayed Values

The display automatically cycles through all values every 3 seconds. This means the display is showing every 3 seconds the live values of Dew point, Temperature, Humidity and Pressure (if the dew point transmitter with pressure sensor) and is cycling through these automatically.

### 8.3 Display Rotation

The display can be easily rotated by 340° to fit your application. To do this, please loosen the two hex-screws at both sides of the dew point transmitter. Do not full unscrew them, only loosen them. Now you can turn the display by 340°. When the desired position is achieved, tighten the two hex-screws from both sides to fix the display position.

## 9 Signal Outputs

### 9.1 Analog Output

Depending on the version, the device provides a 2-wire or 3-wire analog output. The analog output ranges 4 ... 20 mA.

- The 2-wire analog output is a current loop (loop-powered sensor).
- The 3-wire analog output is an active current output.

The following table shows the standard scaling of the analog output.

Output	Scaling
4 mA	-100°C Td
20 mA	+20°C Td

For other ranges, please contact the manufacturer. The analog output can be allocated to the temperature, dew point, and humidity.

### 9.2 Modbus/RTU Output

#### 9.2.1 Modbus Information

The default settings of the Modbus interface are as follows.

Mode	: RTU
Baud rate	: 19200
Device address	: Last two digits of serial number
Framing / parity / stop bit	: 8 / N / 1
Response time	: 1 second
Response delay	: 0 ms
Inter-frame spacing	: 7 char

Response message that the device returns to the master:

- Function code: 03

The information for the byte order is shown in the table below:

**Byte order for 2-byte and 4-byte data**

Byte Order	Sequence				Data Type
	1st	2nd	3rd	4th	
1-0-3-2	Byte 1 (MMMMMMMM*)	Byte 0 (MMMMMMMM *)	Byte 3 (SEEEEEEE)	Byte 2 (EMMMMMMM *)	FLOAT
1-0-3-2	Byte 1	Byte 0 LSB	Byte 3 MSB	Byte 2	UINT32 INT32
1-0	Byte 1 MSB	Byte 0 LSB	---	---	UINT16 INT16
1-0	Byte 1 XXX *	Byte 0 DATA	---	---	UINT8 INT8

**Byte order for 8-byte data**

Byte order	Sequence								Data Type
	1st	2nd	3rd	4th	5th	6th	7th	8th	
1-0-3-2- 5-4-7-6	Byte 1	Byte 0	Byte 3	Byte 2	Byte 5	Byte 4	Byte 7	Byte 6	User defined

\* S: Sign, E: Exponent, M: Mantissa, XXX: no value

**Explanations of MSB and LSB**

- 
- MSB** MSB refers to Most Significant Byte first, which follows the Big-Endian byte order.  
 For example, if the main system follows the MSB first order:  
 When the 4-byte floating number, in the order of Byte1-Byte0-Byte3-Byte2, is received from the slave (sensor), the master must change the byte order to Byte3-Byte2-Byte1-Byte0 for the correct display of the value.
- 
- LSB** LSB refers to Least Significant Byte first, which follows the Little-Endian byte order.  
 For example, if the main system follows the LSB first order:  
 When the 4-byte floating number, in the order of Byte1-Byte0-Byte3-Byte2, is received from the slave (sensor), the master must change the byte order to Byte0-Byte1-Byte2-Byte3 for the correct display of the value.
-

**Note:** If your application needs other Modbus settings, please state it in the order. Modbus communication settings as well as other settings can be changed by the service App S4C-DP or through the windows based Service Software.

### 9.2.2 Holding Register Table for Modbus/RTU

<b>Modbus Register Address</b>	<b>Channel description</b>	<b>Read/Write</b>	<b>Data Type</b>	<b>Data Length</b>
2000	Group ID	R	INT16U	2-Byte
2001	Device ID	R	INT16U	2-Byte
2002	Serial number	R	INT32U	4-Byte
2004	FW/HW	R	INT16U	2-Byte
2005	Calibration date	R	DOUBLE	8-Byte
2009	Valid days from calibration date	R	INT16U	2-Byte
2010	Measuring Channel number	R	INT16U	2-Byte
2011	Device name	R	string	16-Byte
2100	Alternative humidity unit	R/W	INT16U	2-Byte
2101	Static pressure (in bar(g))	R/W	FLOAT	4-Byte
2103	Atmospheric pressure (in hPa)	R/W	FLOAT	4-Byte
2200	Unit+Resolution+Data type of Dew point	R	INT16U	2-Byte
2201	Unit+Resolution+Data type of Alternative humidity	R	INT16U	2-Byte
2202	Unit+Resolution+Data type of Pressure	R	INT16U	2-Byte
2203	Unit+Resolution+Data type of Temperature	R	INT16U	2-Byte
2300	Status	R	INT16U	2-Byte
2301	Channel Value of Dew point	R	FLOAT	4-Byte
2303	Channel Value of Alternative humidity	R	FLOAT	4-Byte
2305	Channel Value of Pressure	R	FLOAT	4-Byte
2307	Channel Value of Temperature	R	FLOAT	4-Byte

- "Unit+Resolution+Data type" Channel

- First byte is unit.

1	°C
2	°F
3	% rH
4	°C Td
5	°F Td
7	mg/m <sup>3</sup>

8	g/kg
9	g/m <sup>3</sup>
30	ppm[v]
31	°C Td atm.
32	°F Td atm.
35	kPa(g)

36	MPa(g)
38	bar(g)
39	psi(g)
54	g/m <sup>3</sup> atm.
55	mg/m <sup>3</sup> atm.

- Second byte:

Bit7	Bit6	Bit5	Bit4	Bit3	Bit2	Bit1	Bit0
Data type:				Resolution:			
0	float			0	0		
1	4-byte unsigned integer			1	0.0		
2	double			2	0.00		
				3	0.000		
				4	0.0000		



### - "Status" channel

The highest bit is used for indicating if any sensor setting is changed by users. The rest bits are used for indicating if the measuring channels that follows the Status channel are working properly or not.

Bit	Description
15	0: Sensor settings have never been changed since last reading from the master. 1: Sensor settings have been changed since last reading from the master
0	0: The 1st measuring channel that follows the Status channel (addressed 2301) is working properly. 1: This measuring channel is not working properly.
1	0: The 2nd measuring channel that follows the Status channel (addressed 2303) is working properly. 1: This measuring channel is not working properly.
2	0: The 3rd measuring channel that follows the Status channel (addressed 2305) is working properly. 1: This measuring channel is not working properly.
3	0: The 4th measuring channel that follows the Status channel (addressed 2307) is working properly. 1: This measuring channel is not working properly.
4 ... 14	Not used

## 10 Optional Accessories

### 10.1 Measuring Chambers

There are different types of measuring chambers for example Measuring chamber with quick connector, by-pass chamber with in and out connection, measuring chamber for dryer installation, or high pressure chamber. The measuring chambers and their order numbers for the S220 OEM are listed as follows:

Order No.	Description
A699 3491	Measuring chamber with quick connector, up to 1.5 MPa, 2 l/min purge @ 0.8 MPa
A699 3493	Measuring chamber by-pass, up to 1.5 MPa, 6 mm hose connection as in- and outlet

For more information, please contact your distributor or the manufacturer.

### 10.2 Wireless DP Transmitter Adapter

The Wireless DP Transmitter Adapter provides a wireless interface between the mobile phone App S4C-DP and the S220. With this DP Adapter, you can manage the S220 settings through the free mobile phone App S4C-DP. For details, see *Wireless DP Transmitter Adapter* instruction manual.

## 11 Calibration

The instrument is calibrated ex work. The exact calibration date is printed on the certificate that is supplied together with the instrument . The accuracy of the instrument is regulated by the on-site conditions, and parameters such as oil, high humidity, and other impurities can affect the calibration and furthermore the accuracy. Therefore we recommend you calibrate the instrument at least once per year. The calibration is excluded from the instrument warranty. Please contact the manufacturer for details.

## 12 Maintenance

Please observe from time to time the sinter cap. If it appears to be dirty, it is recommended to replace it for this please contact the manufacturer.



### **ATTENTION!**

**Contaminated filters can lead to longer response time and to wrong measurements.**

## 13 Disposal or Waste



Electronic devices are recyclable material and do not belong in the household waste.

The device, the accessories and its packings must be disposed according to your local statutory requirements.

The dispose can also be carried by the manufacturer of the product, for this please contact the manufacturer.

---

**SUTO iTEC GmbH**

Grißheimer Weg 21  
D-79423 Heitersheim  
Germany

Tel: +49 (0) 7634 50488 00  
Email: [sales@suto-itec.com](mailto:sales@suto-itec.com)  
Website: [www.suto-itec.com](http://www.suto-itec.com)

**SUTO iTEC (ASIA) Co., Ltd.**

Room 10, 6/F, Block B, Cambridge Plaza  
188 San Wan Road, Sheung Shui, N.T.  
Hong Kong

Tel: +852 2328 9782  
Email: [sales.asia@suto-itec.com](mailto:sales.asia@suto-itec.com)  
Website: [www.suto-itec.com](http://www.suto-itec.com)

---

**SUTO iTEC Inc.**

5460 33rd St SE  
Grand Rapids, MI 49512  
USA

Tel: +1 (616) 800-7886  
Email: [sales.us@suto-itec.com](mailto:sales.us@suto-itec.com)  
Website: [www.suto-itec.com](http://www.suto-itec.com)

---

All rights reserved ©

Modifications and errors reserved  
S220 OEM\_G1-2\_im\_en\_V2024-1-1