

Instruction and Operation Manual

S011

Pressure Transmitter



Dear Customer,

Thank you for choosing our product.

The operating instructions must be read in full and carefully observed before you start up the device. The manufacturer cannot be held liable for any damage which occurs as a result of non-observance or non-compliance with this manual.

Should the device be tampered with in any manner other than a procedure which is described and specified in the manual, the warranty is cancelled and the manufacturer is exempt from liability.

The device is destined exclusively for the described application.

SUTO offers no guarantee for the suitability for any other purpose. SUTO is also not liable for consequential damage resulting from the delivery, capability or use of this device.

Revision: 2025-1



Last modifications: December, 2025

Table of contents

1 Safety Instructions.....	4
2 Registered Trademarks.....	6
3 Application.....	7
4 Features.....	7
5 Technical Data.....	8
5.1 General.....	8
5.2 Electrical Data.....	8
5.3 Output Signals.....	9
5.4 Accuracy	9
6 Dimensional Drawing.....	9
7 Installation	10
7.1 Installation Requirements.....	10
7.2 Installation Procedure.....	10
7.3 Electrical Connection.....	11
8 Signal Output.....	12
8.1 Data Format.....	12
8.2 Protocol Frame Analysis.....	12
8.3 Register.....	13
9 Configuration.....	14
10 Calibration.....	15
11 Maintenance.....	16
12 Disposal of Waste.....	16

1 Safety Instructions

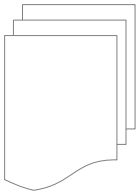

Please check if this instruction manual matches with the product type.

Please observe all notes and instructions indicated in this manual. It contains essential information which have to be observed before and during installation, operation and maintenance. Therefore this instruction manual has to be read carefully by the technician as well as by the responsible user / qualified personnel.

This instruction manual has to be available at the operation site of the Pressure Transmitter at any time. In case of any obscurities or questions, regarding this manual or the product, please contact the manufacturer.



WARNING!

Compressed air!

Any contact with quickly escaping air or bursting parts of the compressed air system can lead to serious injuries or even death!

- Do not exceed the maximum permitted pressure range.
- Only use pressure tight installation material.
- Avoid that persons get hit by escaping air or bursting parts of the instrument.
- The system must be pressureless during maintenance work.

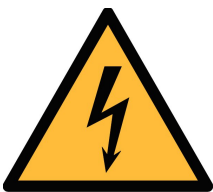

WARNING!

Voltage used for supply!

Any contact with energized parts of the product, may lead to a electrical shock which can lead to serious injuries or even death!

- Consider all regulations for electrical installations.
- The system must be disconnected from any power supply during maintenance work.
- Any electrical work on the system is only allowed by authorized qualified personal.

**ATTENTION!****Permitted operating parameters!**

Observe the permitted operating parameters, any operation exceeding this parameters can lead to malfunctions and may lead to damage on the instrument or the system.

- Do not exceed the permitted operating parameters.
- Make sure the product is operated in its permitted limitations.
- Do not exceed or undercut the permitted storage and operation temperature and pressure.
- The product should be maintained and calibrated frequently, at least annually.

General safety instructions

- It is not allowed to use the product in explosive areas.
- Please observe the national regulations before/during installation and operation.

Remarks

- It is not allowed to disassemble the product.
- Always use spanner to mount the product properly.

**ATTENTION!****Measurement values can be affected by malfunction!**

The product must be installed properly and frequently maintained, otherwise it may lead to wrong measurement values, which can lead to wrong results.

- Do not exceed the maximum operation temperature at the sensors tip.

Storage and transportation

- Make sure that the transportation temperature of the sensor is between -40 ... +85°C.
- For transportation it is recommended to use the packaging which comes with the sensor.
- Please make sure that the storage temperature of the sensor is between -40 ... +85°C.
- Avoid direct UV and solar radiation during storage.
- For the storage the humidity has to be <90%, no condensation.

2 Registered Trademarks

SUTO®

Registered trademark of SUTO iTEC

MODBUS®

Registered trademark of the Modbus Organization, Hopkinton, USA

3 Application

The S011 Pressure Transmitter is designed to measure the pressure of compressed air and gases within the permissible operating parameter. Detailed parameters can be found in the technical data section.

The S011 Pressure Transmitter can measure pressure values in MPa, kPa, or bar.

The S011 Pressure Transmitter is mainly used in compressed air systems in industrial environment. It is not developed to be used in explosive areas. For the use in explosive areas please contact the manufacturer.

4 Features

- Highly accurate and affordable industrial Pressure Transmitter
- Excellent anti-interference capability (EMC, EMI)
- Salt-spray, temperature and humidity test
- IP66 protection
- Modbus/RTU interface

5 Technical Data

5.1 General

CE	
Parameters	Standard unit pressure: MPa
Sensor	Thin-film measuring cell
Measuring medium	Air, gas (non corrosive gas)
Measuring range	0 ... 1.6 MPa (g) (S694 1887 / S694 2559) 0 ... 4.0 MPa (g) (S694 1888 / S694 2562) 0 ... 0.16 MPa (a) (S694 2563)
Temperature of the meas. medium	-30 ... +85°C
Operating temperature	-40 ... +85°C
Temperature compensation range	-40 ... 85°C
Storage temperature	-40 ... +125°C
Overload pressure	1.5 x F.S.
Burst pressure	2.0 x F.S.
Casing material	Stainless steel
Protection class	IP66
Dimensions	See dimensional drawing on the next page
Screwing thread	G 1/4" A (ISO 228/1)
Electrical connection	M12, 5 pins
Vibration resistance	10 g RMS, 20 ... 2000 Hz
Weight	70 g

5.2 Electrical Data

Power supply	24 VDC (12 ... 36 VDC)
--------------	------------------------

5.3 Output Signals

Modbus output	Modbus RTU Baud rate: 19200 Device address: last two digits of the serial number Framing/ Parity/ Stop bit: 8,N,1 Response timeout: 1 second Response delay: 0 ms Inter-frame spacing: 7 char
---------------	---

5.4 Accuracy

Accuracy	S694 1887 / S694 1888 / S694 2559 / S694 2562: $\pm 0.25\%$ F.S. S694 2563: $\pm 0.5\%$ F.S.
Long-term drift	$\leq \pm 0.3\%$ F.S. / year

6 Dimensional Drawing

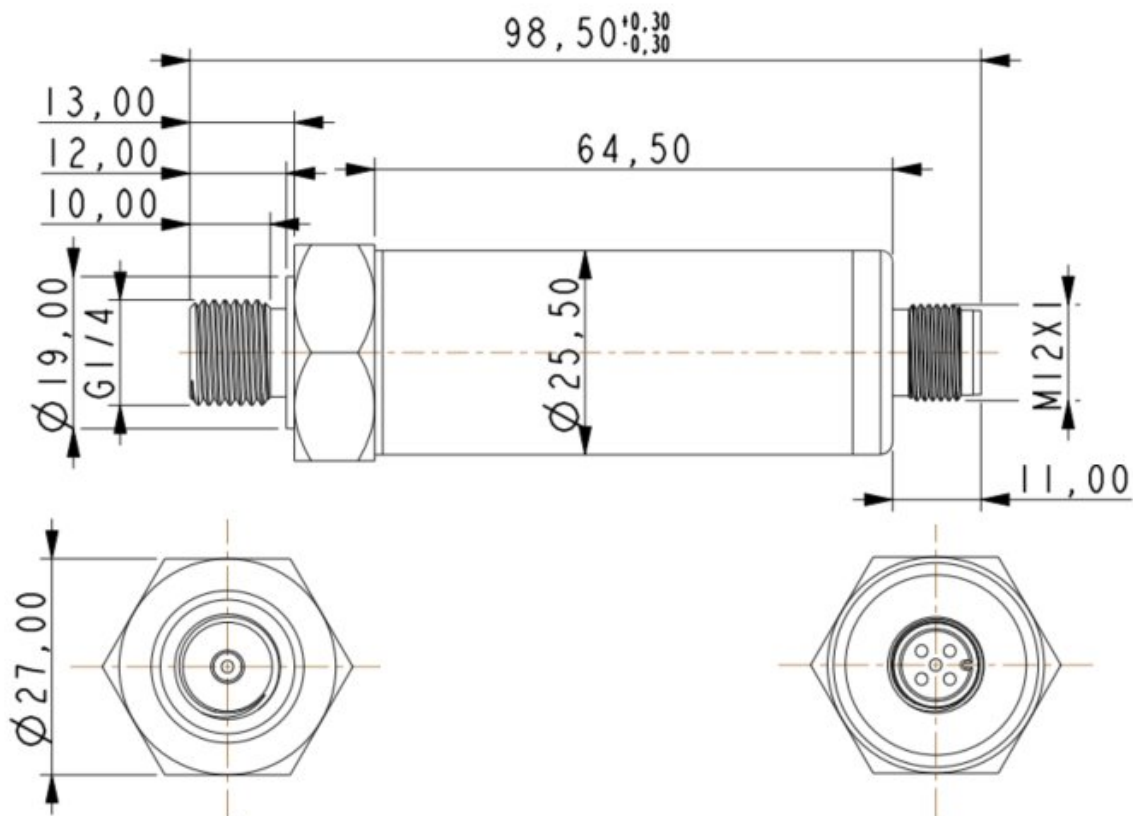

7 Installation

Please make sure that all components listed below are included in your package.

Qty	Description	Item No.
1	S011 Pressure Transmitter	S694 2559 / S694 1887 (1.6 MPa (g)) S694 2562 / S694 1888 (4.0 MPa (g)) S694 2563 (0.16 MPa (a))
1	M12 connector	C219 0060
1	Instruction manual	No P/N
1	Calibration certificate	No P/N



ATTENTION!

Wrong measurement is possible, if the Pressure Transmitter is not installed correctly.

The Pressure Transmitter is for indoor use only! At an outdoor installation, the Pressure Transmitter must be protected from solar radiation and rain.

7.1 Installation Requirements

To install the Pressure Transmitter a ball valve or a nozzle is needed. The inner thread must be G 1/4".

7.2 Installation Procedure

The following steps explain the procedure of an appropriate installation.

Installation of the Pressure Transmitter

Screw the Pressure Transmitter tightly to the nozzle.

Removal of the Pressure Transmitter

Loose unscrew the Pressure Transmitter.

7.3 Electrical Connection

The cables are connected to the Pressure Transmitter through the M12 connector.

Cable connection (Modbus)

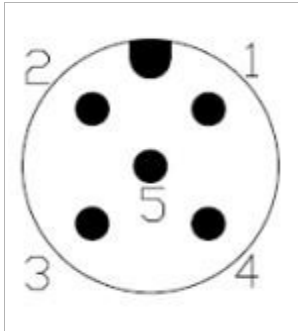

Pin	Signal	Colour	Legend to pin assignment
1	N/A	brown	Not available
2	-V _B	white	Negative supply voltage
3	+V _B	blue	Positive supply voltage
4	D+	black	Modbus data +
5	D-	grey	Modbus data -



ATTENTION!

Do not screw the M12 plug using force. Otherwise, it may damage the connecting pins.

8 Signal Output

8.1 Data Format

The pressure measurement values in the data frame are expressed as double-byte integer numbers. When reading the pressure measurement, the number of decimal places is read first, and then the size of the measured value is determined.

8.2 Protocol Frame Analysis

The function code of read-holding register is 03.

The request frame format is as follows:

Address	Function Code	Register Address	Number of Registers	Checksum
1 byte	1 byte	2 bytes	2 bytes	2 bytes

The response frame format is as follows:

Address	Function Code	Data Length	Data	Checksum
1 byte	1 byte	1 bytes	Number of Registers ×2 bytes	2 bytes

Example:

Address of read-holding register: 0

The data sent: 01 03 00 00 00 00 84 0A

The data received: 01 03 02 00 01 79 84

The function code of write-holding register is 06.

The request frame format is as follows:

Address	Function Code	Register Address	Data	Checksum
1 byte	1 byte	2 bytes	2 bytes	2 bytes

The response frame format is as follows:

Address	Function Code	Data Length	Data	Checksum
1 byte	1 byte	1 bytes	2 bytes	2 bytes

Example:

Address of write-
holding register: 0

The data sent: 01 06 00 00 00 02 08 0B

The data received: 01 06 00 00 00 02 08 0B

8.3 Register

Register Address	Description	Data Type	Operation Type	Value
0	Slave address	Unsigned char	R/W	1 ~ 255
1	Baud rate	Unsigned char	R/W	0: 2400 bps 1: 4800 bps 2: 9600 bps 3: 19200 bps 4: 38400 bps 5: 57600 bps 6: 115200 bps
2	Parity	Unsigned char	R/W	0: None 1: Odd 2: Even
3	Decimal digits	Unsigned char	R	0~4
4	Pressure	Int16	R	-32768~32767 *
5	Pressure unit	Unsigned char	R	1: kPa 2: MPa 5: bar 6: psi 7: Pa

* The value is related with the number of decimal places. For example, if the number of decimal places is 2 and the pressure value is 10023, the actual value is 100.23.

9 Configuration

To configure the Pressure Transmitter, use the S330 / S331 and the S4C-Display software

1. Follow the diagram for wiring.

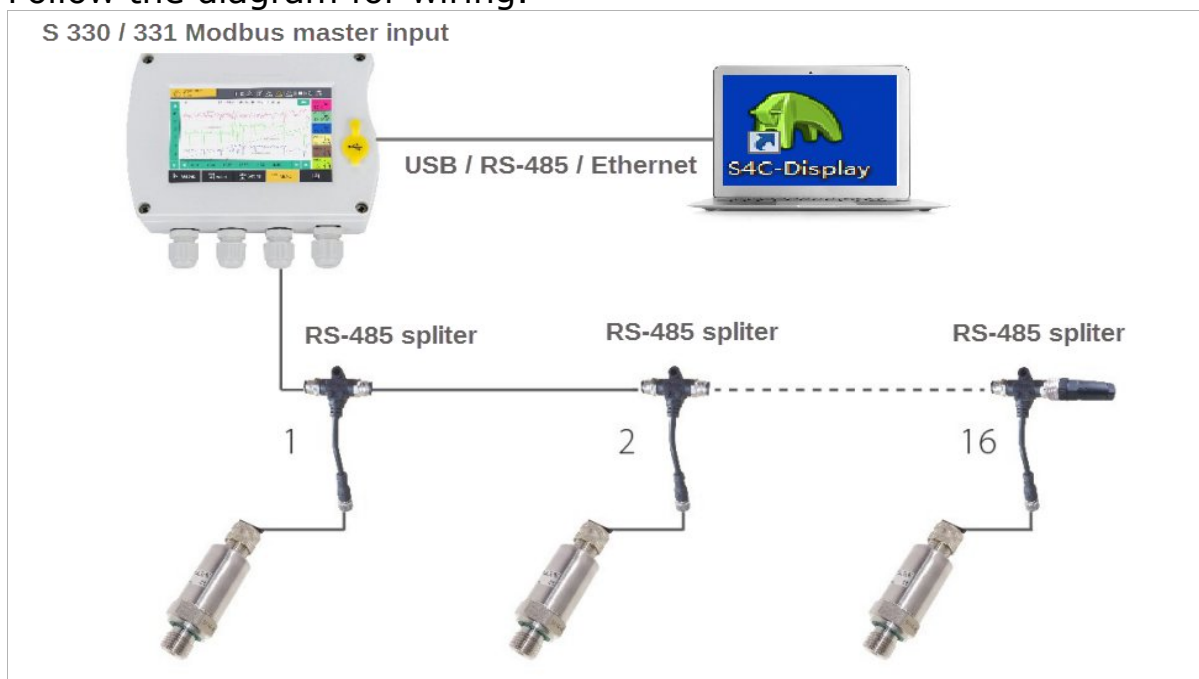

2. Launch the S4C-Display software, and make configuration as follows:
 - A. Configure the pressure transmitters as Modbus input devices to the S330 / S331, which is a Modbus Master.
 - B. Add the pressure transmitter as a third-party device to the Modbus Master.
 - C. Refer to the examples shown below to configure the pressure transmitter information including unit, resolution, value address (Modbus address), measure value type, function code, and display scaling.

Example: the pressure unit is bar, and the decimal place of the sensor output is 2 digits.

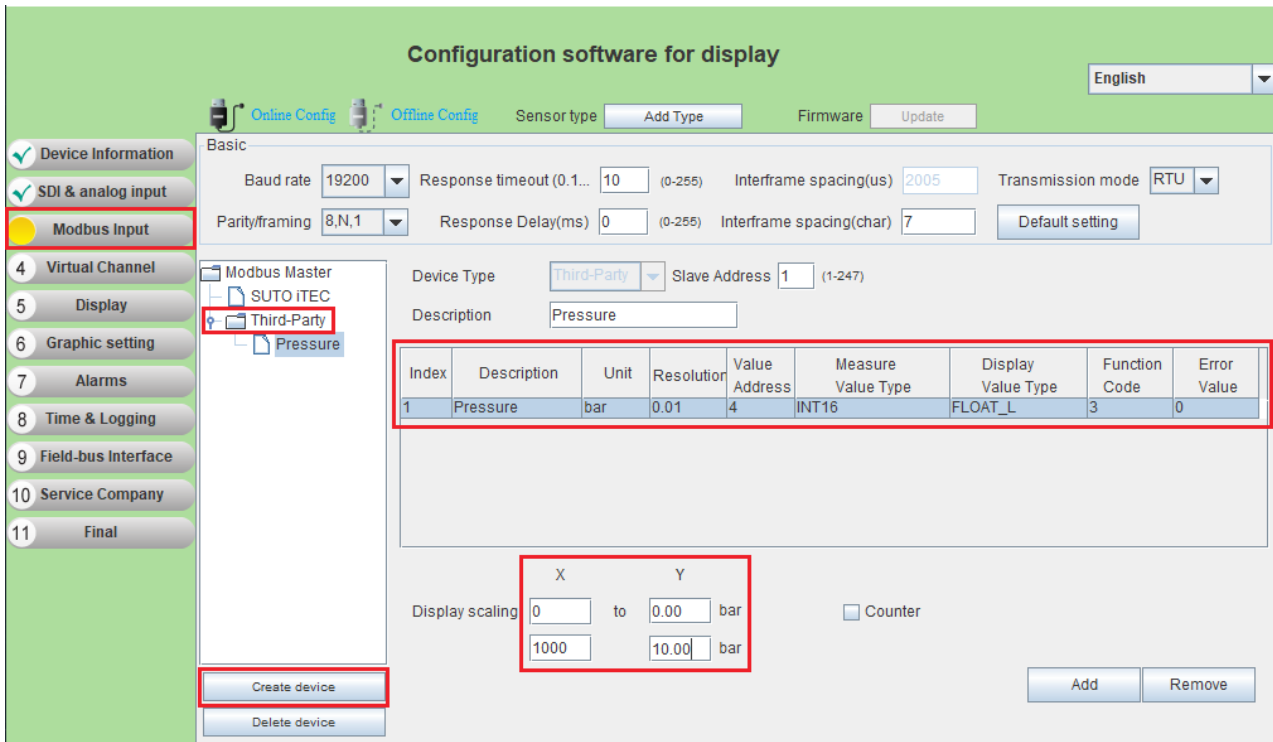

Values of X and Y on the above figure are listed in the table below.

Decimal Digits *	X		Y	
0	0	1000	0	1000
1	0	1000	0.0	100.0
2	0	1000	0.00	10.00
3	0	1000	0.000	1.000
4	0	1000	0.0000	0.1000

* Refer to the register address of 3 in section 8.3 Register.

10 Calibration

The instrument is calibrated ex work. The exact calibration date is printed on the certificate supplied together with the device. Its accuracy is regulated by the on site conditions, parameters like oil, high humidity or other impurities can affect the calibration and furthermore the accuracy. However it is recommended to calibrate the instrument at least once per year. The calibration is excluded from the instruments warranty. For this please contact the manufacturer.

11 Maintenance

To clean the Pressure Transmitter and its accessories it is recommended to use a moist cloth only.



ATTENTION!

Do not use isopropyl alcohol to clean the Pressure Transmitter and its accessories !

12 Disposal of Waste



Electronic devices are recyclable material and do not belong in the household waste.

The Pressure Transmitter, the accessories and its packings must be disposed according to your local statutory requirements. The disposal can also be carried by the manufacturer of the product, for this please contact the manufacturer.

SUTO iTEC GmbH

Grißheimer Weg 21
D-79423 Heitersheim
Germany

Tel: +49 (0) 7634 50488 00
Email: sales@suto-itec.com
Website: www.suto-itec.com

SUTO iTEC (ASIA) Co., Ltd.

Room 10, 6/F, Block B, Cambridge Plaza
188 San Wan Road, Sheung Shui, N.T.
Hong Kong

Tel: +852 2328 9782
Email: sales.asia@suto-itec.com
Website: www.suto-itec.com

SUTO iTEC Inc.

5460 33rd St SE
Grand Rapids, MI 49512
USA

Tel: +1 (616) 800-7886
Email: sales.us@suto-itec.com
Website: www.suto-itec.com

All rights reserved ©

Modifications and errors reserved

S011_IM_EN_2025-1_SUTO logo_a