

Instruction and Operation Manual

S431 OEM V2

Pitot Tube Compressor Flow Meter (Inline)



Dear Customer,

Thank you for choosing our product.

Before starting up the device please read this manual in full and carefully observe the instructions stated. The manufacturer cannot be held liable for any damage which occurs as a result of non-observance or non-compliance with this manual.

Should the device be tampered with in any manner other than a procedure which is described and specified in the manual, the warranty is void and the manufacturer is exempt from liability.

The device is designed exclusively for the described application.

SUTO offers no guarantee for suitability for any other purpose. SUTO is also not liable for consequential damage that results from the delivery, capability, or use of this device.

Revision: 2025-1



Last modifications: December, 2025

Table of contents

1	Safety Instructions.....	4
2	Registered Trademarks.....	6
3	RF Exposure Information and Statement.....	7
4	Application.....	8
5	Features.....	8
6	Technical Data.....	9
6.1	General Data.....	9
6.2	Signal / Interface and Supply.....	10
6.3	General Data.....	10
6.4	Flow Ranges.....	11
7	Dimensional Drawing.....	13
8	Installation.....	14
8.1	Installation Options.....	14
8.2	Inlet and Outlet Sections.....	14
8.3	Welding Nipple and Welding Fixture.....	16
8.4	Remove Flow Meter	19
8.5	Electrical Connection.....	20
9	Configuration.....	21
9.1	Register.....	21
9.2	Use Service App S4C-FS.....	21
9.2.1	Flow Settings.....	22
9.2.2	Unit Settings.....	23
9.2.3	Perform the Zero Flow Calibration.....	24
9.2.4	Calibration inside Compressor.....	25
9.2.5	Upload Settings.....	26
9.2.6	Download Settings.....	27
10	Signal Outputs.....	29
10.1	Analog Output.....	29
10.2	Pulse Output.....	29
10.3	Modbus Interface	31
10.4	Connection between S431 Outputs and Customer Equipment...33	
11	Maintenance.....	34
12	Disposal or Waste.....	34

1 Safety Instructions

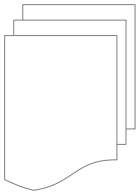

Please check if this instruction manual matches the product type.

Please observe all notes and instructions indicated in this manual. It contains essential information that must be observed before and during installation, operation, and maintenance.

Therefore this instruction manual must be read carefully by the technician and by the responsible user / qualified personnel.

This instruction manual must be available at the operation site of the flow meter at any time. In case of any obscurities or questions regarding this manual or the product, please contact the manufacturer.



WARNING!

Compressed air!

Any contact with quickly escaping air or bursting parts of the compressed air system can lead to serious injuries or even death!

- Do not exceed the maximum permitted pressure range (see sensors label).
- Only use pressure-tight installation material.
- Avoid that persons get hit by escaping air or bursting parts of the instrument.
- The system must be pressureless during maintenance work.

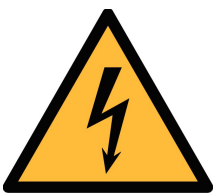

WARNING!

Voltage used for supply!

Any contact with energized parts of the product might lead to an electrical shock which can lead to serious injuries or even death!

- Consider all regulations for electrical installations.
- The system must be disconnected from any power supply during maintenance work.
- Any electrical work on the system is only allowed by authorized qualified personal.

**ATTENTION!****Permitted operating parameters!**

Observe the permitted operating parameters, any operation exceeding this parameters can lead to malfunctions and might lead to damage on the instrument or the system.

- Do not exceed the permitted operating parameters.
- Make sure that the product is operated in its permitted limitations.
- Do not exceed or undercut the permitted storage and operating temperature and pressure.
- The product should be maintained and calibrated frequently, at least annually.

General safety instructions

- It is not allowed to use the product in explosive areas.
- Please observe the national regulations before/during installation and operation.

Remarks

- It is not allowed to disassemble the product.
- Always use a spanner to mount the product properly.

**ATTENTION!****Measurement values can be affected by malfunction!**

The product must be installed properly and frequently maintained. Otherwise it might lead to wrong measurement values, which can lead to wrong results.

- Always observe the direction of the flow when installing the flow meter. The flow direction is indicated on the housing.
- Do not exceed the maximum operating temperature at the sensor tip.
-

Storage and transportation

- Make sure that the transportation temperature of the flow meter is between -30°C ... +70°C.
- For transportation it is recommended to use the packaging which comes with the flow meter.
- Please make sure that the storage temperature of the flow meter is between -30 ... +70°C.
- Avoid direct UV and solar radiation during storage.
- For the storage, the humidity must be <95% with no condensation.

2 Registered Trademarks

Trademark	Trademark owner
SUTO®	SUTO iTEC
MODBUS®	Modbus Organization, Hopkinton, USA
Android™, Google Play	Google LLC

3 RF Exposure Information and Statement

This equipment complies with FCC RF radiation exposure limits set forth for an uncontrolled environment. This equipment should be installed and operated with minimum distance of 20 cm between the radiator and your body.

This device complies with part 15 of the FCC rules. Operation is subject to the following two conditions: (1) this device might not cause harmful interference, and (2) this device must accept any interference received, including interference that might cause undesired operation.

Remark: The manufacturer is not responsible for any radio or TV interference caused by unauthorized modifications to this equipment. Such modifications could void the user's authority to operate the equipment.

Remark: This equipment has been tested and found to comply with the limits for a Class B digital device, pursuant to part 15 of the FCC Rules. These limits are designed to provide reasonable protection against harmful interference in a residential installation. This equipment generates uses and can radiate radio frequency energy and, if not installed and used in accordance with the instructions, might cause harmful interference to radio communications. However, there is no guarantee that interference will not occur in a particular installation. If this equipment does cause harmful interference to radio or television reception, which can be determined by turning the equipment off and on, the user is encouraged to try to correct the interference by one or more of the following measures:

- Reorient or relocate the receiving antenna.
- Increase the separation between the equipment and receiver.
- Connect the equipment into an outlet on a circuit different from that to which the receiver is connected.
- Consult the dealer or an experienced radio/TV technician for help.
- This device and its antenna(s) must not be co-located or operating in conjunction with any other antenna or transmitter.

4 Application

The S431 OEM Pitot Tube Compressor Flow Meter (Inline) is designed to measure the air delivery of a compressor. It can be installed at the discharge side inside the compressor where wet and contaminated air occurs.

The S431 can measure the following parameters for compressed air or gases:

Parameter	Default unit
Actual velocity	m/s
Volumetric flow	Sm ³ /h
Pressure	bar
Total consumption	Sm ³
Temperature	°C

5 Features

- Measurement of flow, pressure, and temperature at the compressor outlet
- Measurement of wet air and air at high temperatures
- The minimum cut-off velocity reaches 5 m/s, ensuring measurement accuracy even in the low range.
- Calculation of total consumption
- No straight piping required, — if the S431 is calibrated on the compressor test bench
- Easy to install on welding nipples
- Rugged design for harsh environment: ambient temperatures up to 90°C, vibration proof
- No mechanical wear parts
- One flow meter for DN50 ... DN900
- User calibration through mobile App at the compressor test bench
- Analogue and pulse outputs or Modbus/RTU

6 Technical Data

6.1 General Data

 Contains FCC ID:2ABN2-BG22B1	
Flow	
Accuracy *	$\pm(1.5\% \text{ of reading} + 0.3\% \text{ F.S.})$
Selectable units Volumetric Flow: Mass Flow: Actual Velocity:	Sm ³ /h, Sm ³ /min, Sl/min, Sl/s, Scfm kg/h, kg/min, kg/s, t/h, lb/h m/s, ft/min
Measuring range	See the table in section 6.4.
Repeatability	0.5 % of reading
Sensor	Differential pressure sensor with pitot tube
Sampling rate	3/sec
Turndown ratio	40:1
Response time (t ₉₀)	2 sec
Consumption	
Selectable units	Sm ³ , Sft3, t, lb, Sl, kg
Pressure	
Accuracy	0.5 % FS
Selectable units	bar, psi, kPa, MPa
Measuring range	0 ... 1.6 MPa(g)
Sensor	Piezzo resistive sensor
Temperature	
Accuracy	0.5°C
Selectable units	°C, °F
Measuring range	-20 ... +120°C
Sensor	Pt1000
Reference conditions	
Selectable conditions	20°C 1000 mbar (ISO1217) 0°C 1013 mbar (DIN1343) freely adjustable

6.2 Signal / Interface and Supply

Analog output	
Signal	4 ... 20 mA
Scaling	0 ... max flow
Load	250R
Update rate	1/sec
Pulse output	
Signal	Max 30 V, 200 mA
Scaling	1 pulse per consumption unit
Fieldbus	
Protocol	Modbus/RTU
Supply	
Power supply	12 ... 36 VDC; 60 mA, 1.5 W

6.3 General Data

Configuration	
Wireless	S4C-FS App for mobile phones
Material	
Housing	PC + ABS
Wetted parts	Stainless steel 1.4404 (SUS 316L)
Miscellaneous	
Electrical connection	1 x M12 (5-pole)
Protection class	IP65
Approvals	CE, RoHS, FCC
Process connection	M32 x 1.5 mm welding nipple
Weight	1.7 kg
Operating conditions	
Medium	Wet/dry air, other gases
Medium quality	Non corrosive
Medium temperature	-20 ... +120°C
Medium humidity	No requirements

Operating pressure	0 ... 1.6 MPa(g)
Ambient temperature	-20 ... +85°C
Ambient humidity	<95 % rH
Storage temperature	-30 ... 70°C
Transport temperature	-30 ... 70°C
Pipe sizes	≥DN50

* The specified accuracy is valid only within the minimum and maximum flows that are indicated in section 6.4.

6.4 Flow Ranges

The stated measuring ranges under following conditions:

- Standard flow in air
- Reference pressure: 1000 mbar
- Reference Temperature: +20°C
- Cut-off velocity: 5 m/s

Tube			Volumetric Flow			
			Standard		High-speed	
Inch	DN	Inner diameter (mm)	Min	Max	Min	Max
			Sm ³ /h		Sm ³ /h	
2"	DN50	53.1	31	1,298	32	1,687
2½"	DN65	68.9	55	2,218	55	2,883
3"	DN80	80.9	76	3,084	76	4,010
4"	DN100	100	117	4,760	117	6,189
5"	DN125	125	184	7,500	184	9,751
6"	DN150	150	267	10,854	266	14,110
8"	DN200	200	478	19,482	477	25,327
10"	DN250	250	745	30,465	747	39,605
12"	DN300	300	1,076	43,870	1,076	57,031

Remark:

- The flow is calculated based on medium conditions of air at 6 bar(g), 70 °C, and 90% humidity.

- The flow measurement range is related to the actual inner diameter of the installed pipe. Differences in the inner diameter will result in different maximum and minimum flow values. The exact range can be calculated using Flow Range software, which can be used online from www.suto-itec.com by clicking **Support > Flow Range Calculator**.

SENSOR SELECTION		CALCULATOR OUTPUTS	
Sensor Type	S431	Max. flow	1340 Sm³/h
Measuring section		Min. flow	132 Sm³/h
Measuring range	Standard	Max. velocity	200.0 Sm/s
Pipe inner diameter	54.0	Min. velocity	2.9 m/s

7 Dimensional Drawing

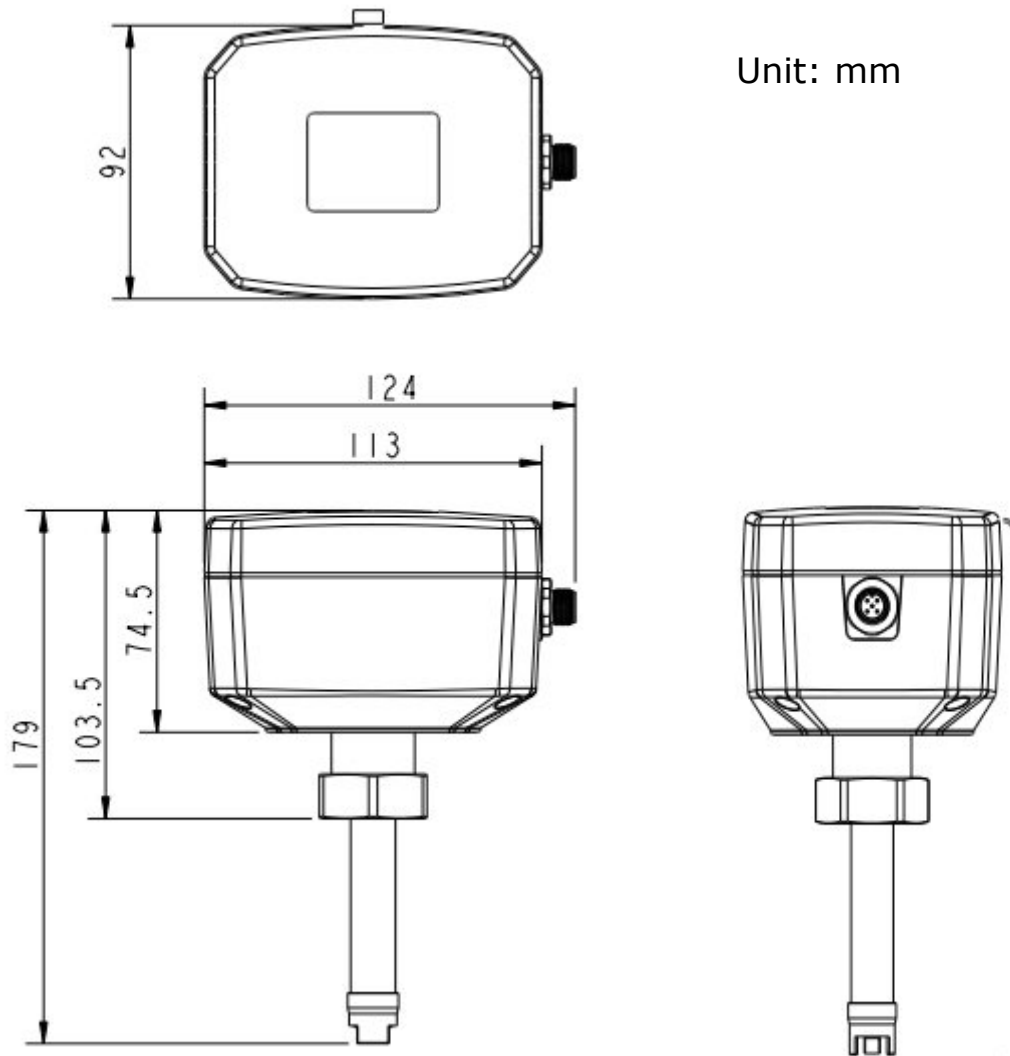

8 Installation

Before you install the flow meter, make sure that all components listed below are included in your package.

Qty	Description	Order No.
1	S431 OEM Pitot Tube Compressor Flow Meter (Inline)	S695 4312
1	Output option Analog / Pulse Modbus/RTU	A4314 A4315
1	O-ring	NA
1	M12 cable 5 m with open ends	A553 0104
1	Instruction manual	NA
1	Calibration certificate	NA

Remark: For the various installations welding nipples are available and need to be ordered separately.

8.1 Installation Options

There are 2 installation options:

- Installation inside compressors
This installation requires a calibration of the S431 together with the compressor in the test stand of compressor maker. For information about how to calibrate, see the section 9.2.4 Calibration inside Compressor.
- Installation outside compressors
This installation requires a straight pipe of a certain length. For information about the straight pipe requirements, see the section 8.2 Inlet and Outlet Sections.

8.2 Inlet and Outlet Sections

Unhindered flow characteristics are achieved if the section in front of the flow meter (inlet) and behind the flow meter (outlet) are sufficiently long, absolutely straight, and free of obstructions such as edges, seams, curves, and so on.

Make sure that enough space exists at your site for an adequate installation as described in this manual.

**ATTENTION!**

The wrong measurement might occur if the flow meter is not installed correctly.

- Pay careful attention to the design of the inlet and outlet sections. Obstructions can cause counter-flow turbulence as well as turbulence in the direction of the flow.
- The flow meter is for indoor use only! At an outdoor installation, the flow meter must be protected from solar radiation and rain.

Remark: If there is any combination of the following situations, the longest straight inlet section must be maintained.

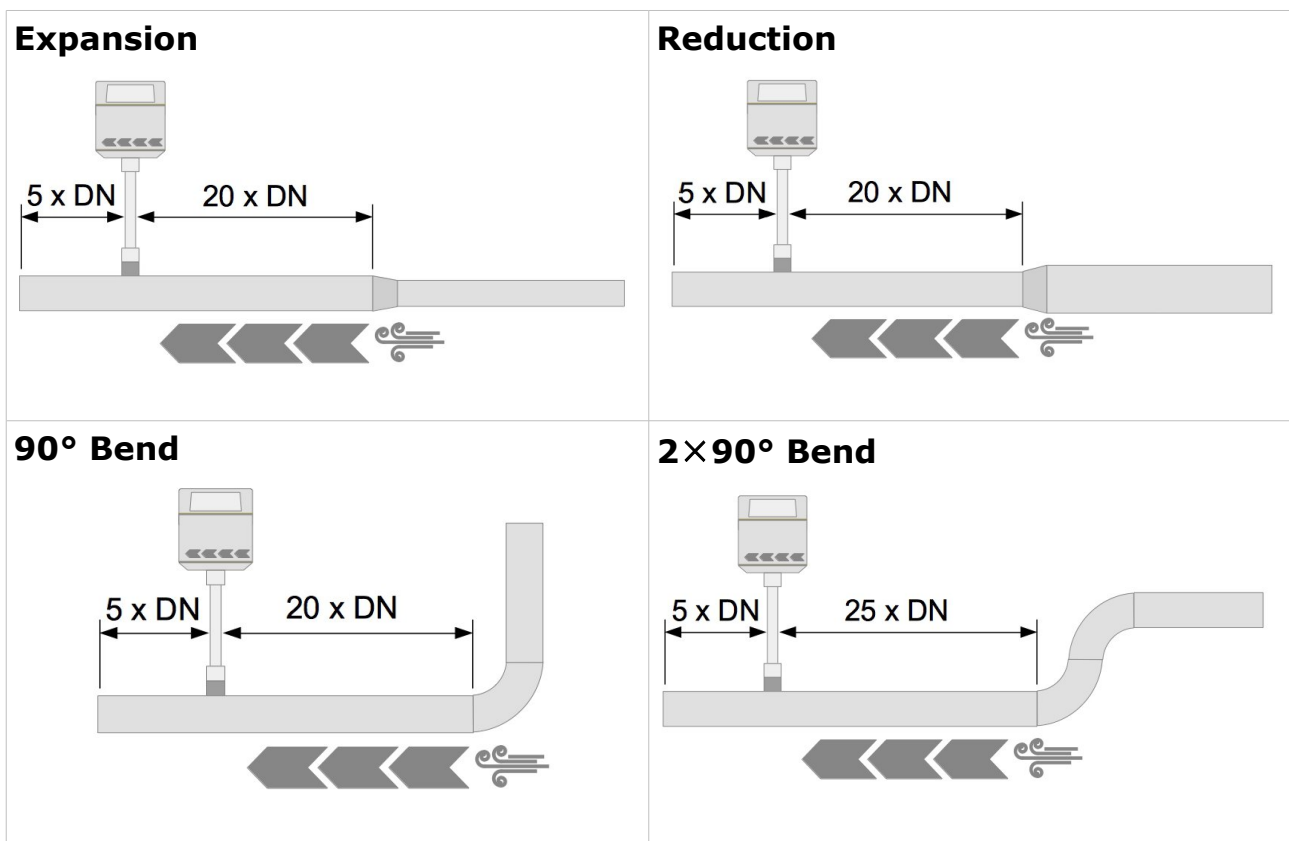

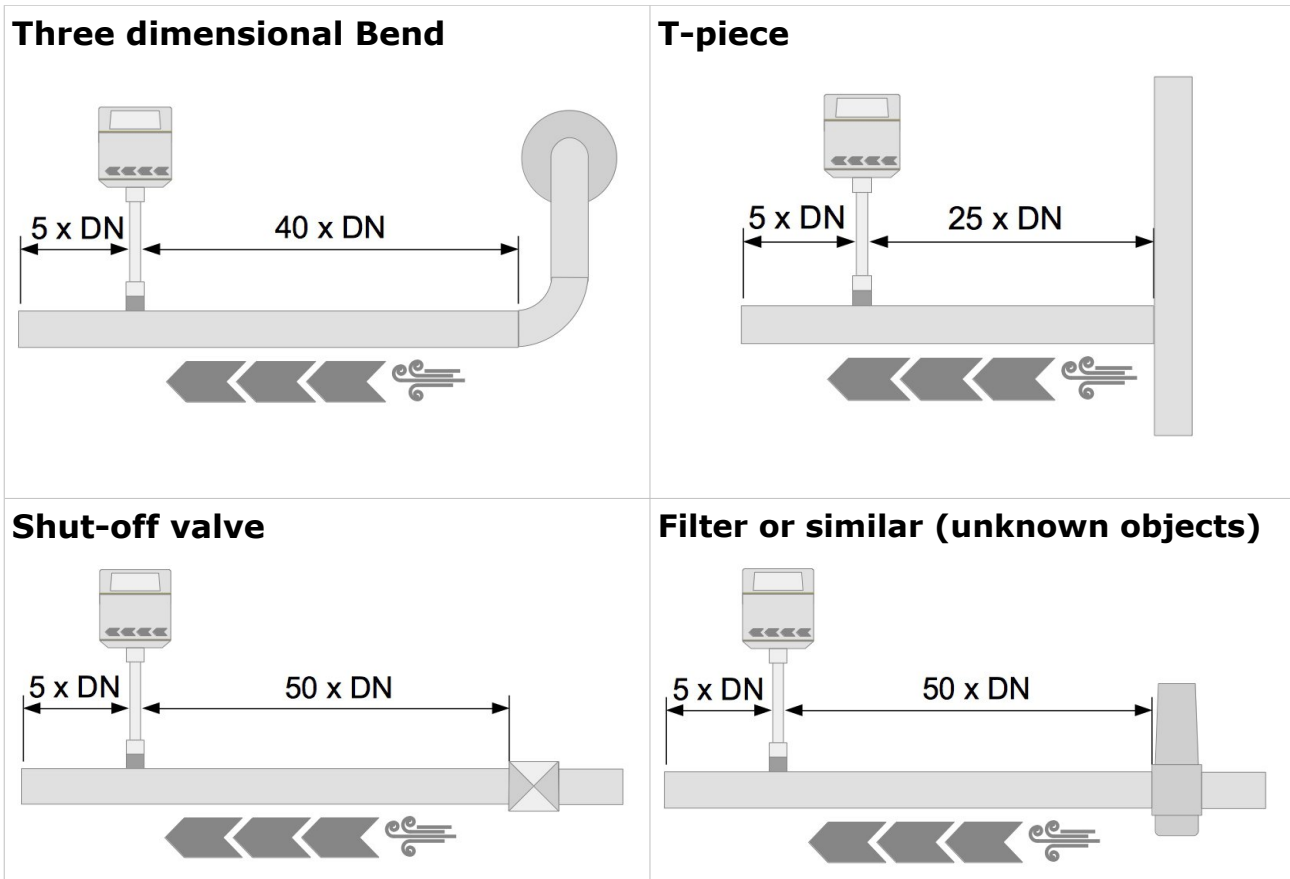

8.3 Welding Nipple and Welding Fixture

In order to install the flow meter, first a hole must be made as follows:

- The diameter of the hole is 18 mm for the installation in a horizontal pipe.
- The diameter of the hole is 21 mm for the installation in a vertical pipe.

Then a welding nipple will be welded onto the pipe. There are 4 types available:

Order No.	Description
A4310	Welding nipple DN50 ... DN80 for horizontal pipes installation
A4311	Welding nipple DN100 ... DN900 for horizontal pipes installation
A4312	Welding nipple DN50 ... DN80 for vertical pipes installation
A4313	Welding nipple DN100 ... DN900 for vertical pipes installation

Horizontal pipe installation - S695 4310

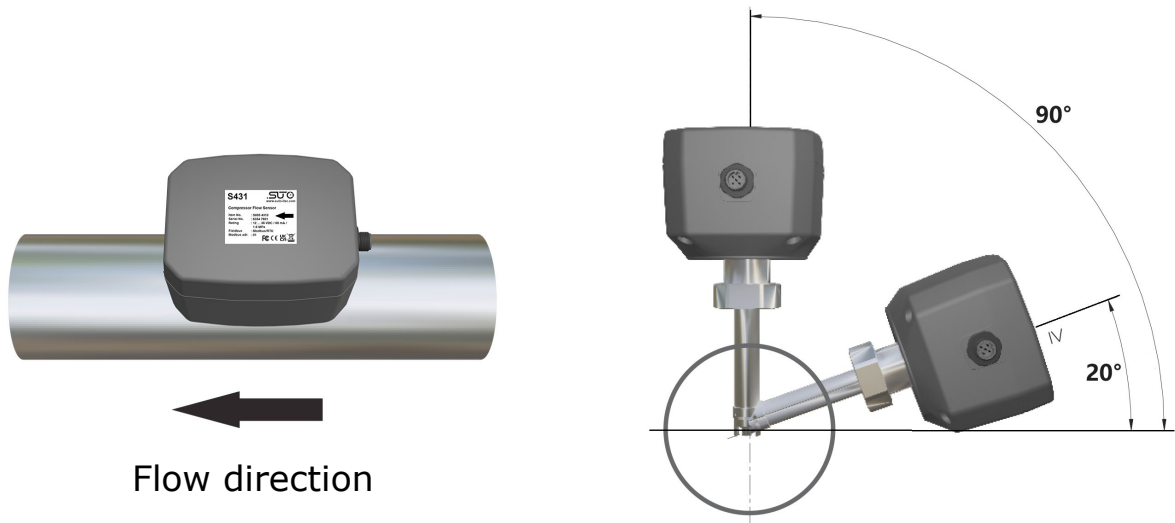

Vertical pipe installation - S695 4311

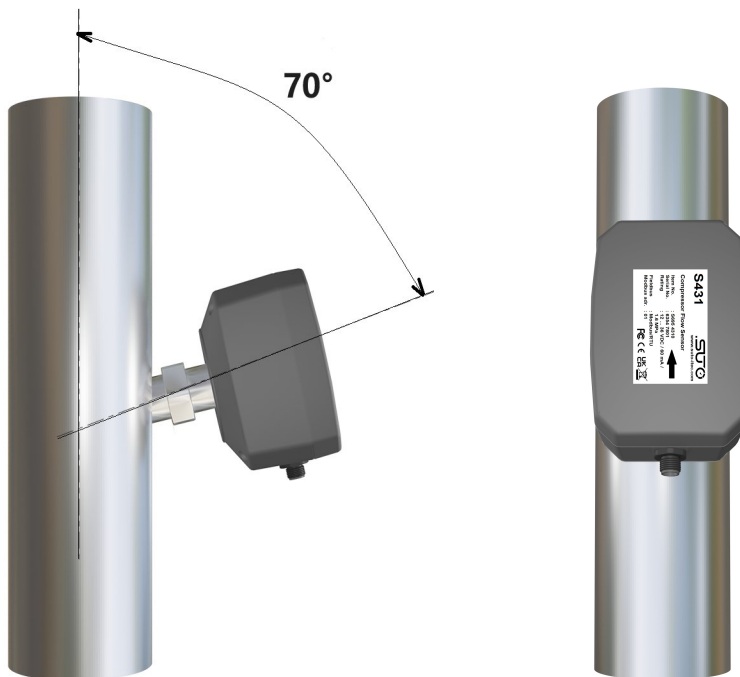

In addition, you also can use the customized welding fixture for welding processing to get the best positioning and welding quality, as shown below.

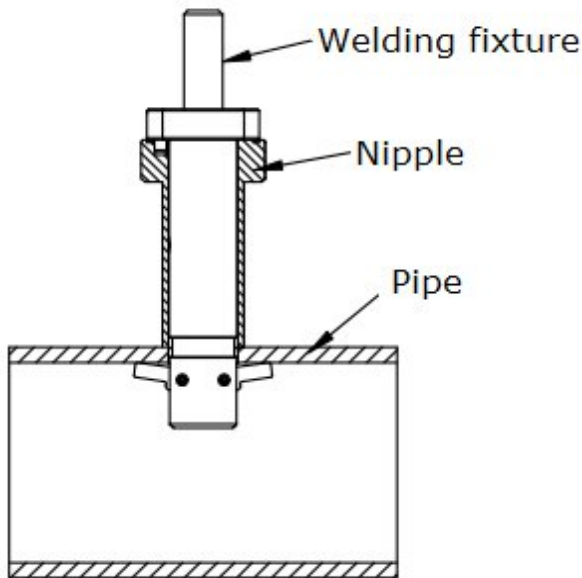

Welding fixture in a horizontal pipe

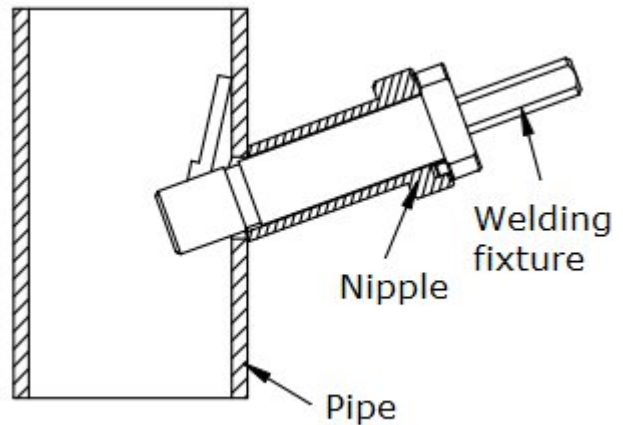

Welding fixture in a vertical pipe

The types of the welding fixtures and their order numbers are as follows:

Order No.	Description
A695 4310	Welding fixture DN50 ... DN80 for horizontal pipe installation
A695 4311	Welding fixture DN100 ... DN900 for horizontal pipe installation
A695 4312	Welding fixture DN50 ... DN80 for vertical pipe installation
A695 4313	Welding fixture DN100 ... DN900 for vertical pipe installation

8.4 Remove Flow Meter



WARNING!

Removing flow meter under pressure can be dangerous! Be aware that the flow meter can be shot out if you do not carefully follow the steps described below!

For your information: Removal of the flow meter is only permitted in a depressurized state!

Follow the steps below to remove the flow meter:

1. Hold the flow meter.
2. Release the connection nut at the connection thread.
3. Pull out the shaft slowly.
4. The measuring section can be closed with the optional closing cap so that the system can operate normally during maintenance of the flow meter.

Follow the steps below to re-install the flow meter after maintenance:

1. Place the O-ring into the recess of the connection nut.
2. Insert the flow meter back to the pipe.
3. Tighten the connection nut.

8.5 Electrical Connection

The S431 has a 5-pole M12 connector for power supply and signal output.

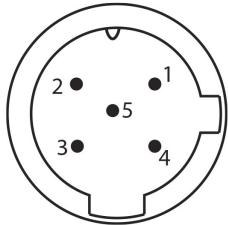

5-pole M12 cable with open ends included

Pin assignment connector plug M12 (5-pole)

Output	Pin 1	Pin 2	Pin 3	Pin 4	Pin 5
Analog/Pulse	+I	-V _B	+V _B	SW	SW
Modbus	GND _M	-V _B	+V _B	D+	D-
Wire color	Brown	White	Blue	Black	Grey

Legend for pin assignment

GND _M	Ground for Modbus/RTU
-V _B	Negative supply voltage
+V _B	Positive supply voltage
+I	Positive 4 ... 20 mA signal
SW	Isolated pulse output (switch)
D+	Modbus/RTU data +
D-	Modbus/RTU data -
N/A	Not applicable



ATTENTION!

Do not screw the M12 connector using force. Otherwise it might damage the connection pins.

9 Configuration

After installing the flow meter, you can change the sensor settings as needed, using the Service App S4C-FS.

Search and installation of the S4C-FS are as follows:

1. On your smart phone, download the **S4C-FS** app from Google Play Store or from the SUTO website.
2. Install **S4C-FS**.

9.1 Register

Before using the S4C-FS App, you must register. Only registered users are able to modify settings. Please get in touch with SUTO service team and provide the required registration information.

9.2 Use Service App S4C-FS

The S4C-FS is an Android and iOS App that enables you to view measurement readings, change settings and perform calibrations on the S431.

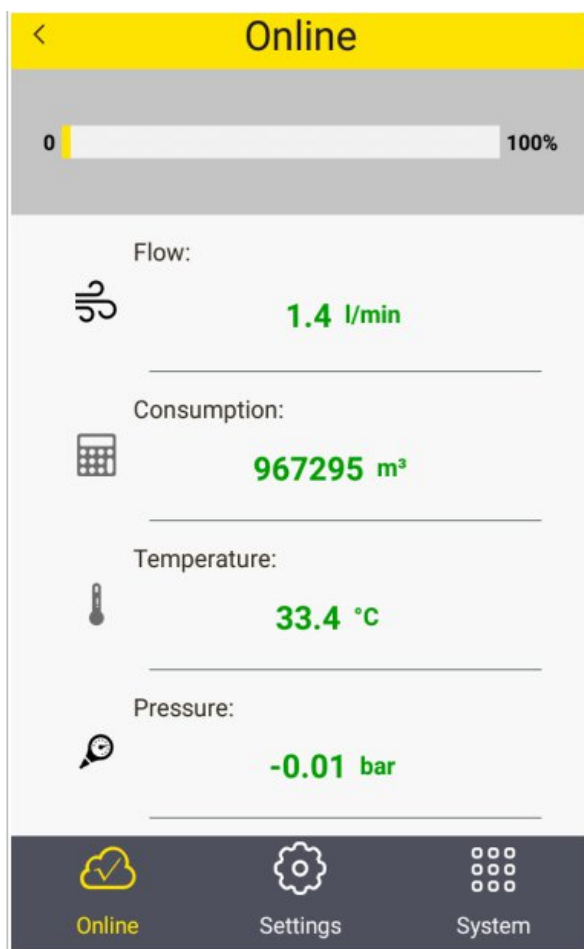

Preparation:

Power on the S431.

As a registered user you can access the flow meter through a wireless connection immediately. If you are not a registered user you need to scan the QR code on the calibration certificate.

Scan QR Code:

In the **System** menu select **Scan QR Code**.

After scanning the QR code signal icon changes from **Orange** to **Green**.

After finishing this step you can return to the online screen and see online values.

9.2.1 Flow Settings

Before any measurement can be done the flow settings need to be entered.

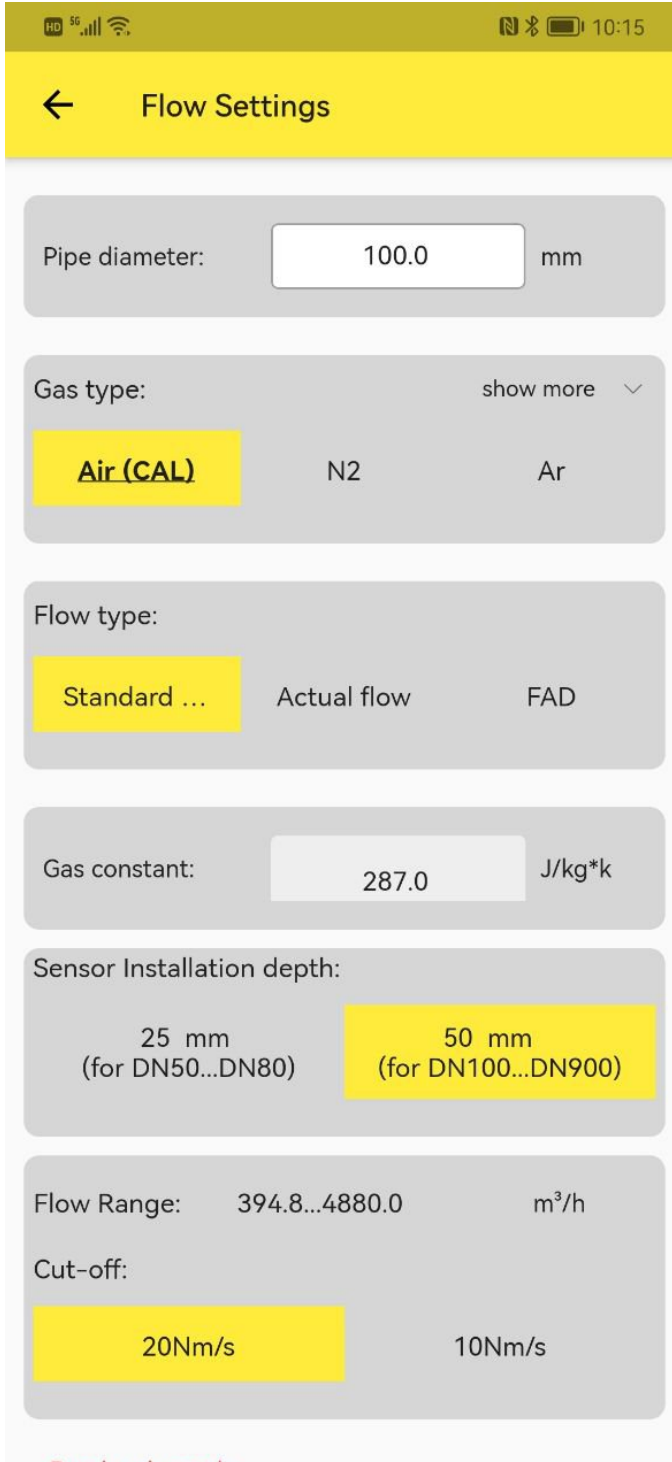

Pipe diameter

Enter the inner diameter of the pipe.

Gas type

Select the medium to measure.

Flow type

Select Standard flow, Actual Flow or FAD (Free Air Delivery).

Gas constant

It is set through the selected gas type. Each gas type has its own specific gas constants. When the gas type is "other", you have to input a gas constant.

Sensor installation depth

You have to select the insertion depth of either 25 mm (DN50 ... DN80) or 50 mm (>DN100).

Cut-Off velocity

The default is 20 Nm/s. The velocity values below this setting appear as zero.

9.2.2 Unit Settings

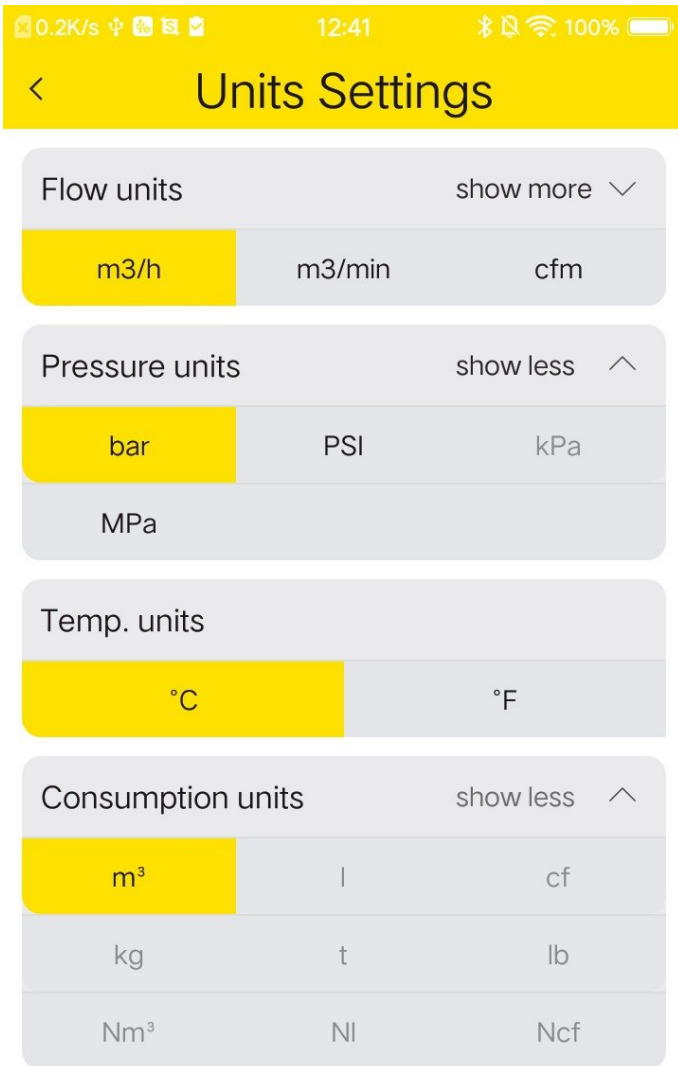

Select the desired physical unit for the different measurement channels.

9.2.3 Perform the Zero Flow Calibration

The zero flow calibration is a compulsory operation for the flow meter installation.

Before you start the zero flow calibration, make the flow meter have been mounted onto the welding nibble and the compressor is switched off – no air delivery!

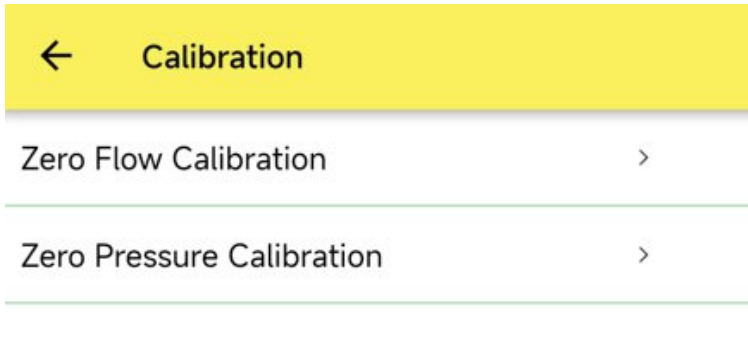

Click **Settings > Calibration > Zero Flow Calibration** to enter the zero flow calibration page. Follow the onscreen instructions to perform the zero flow calibration.

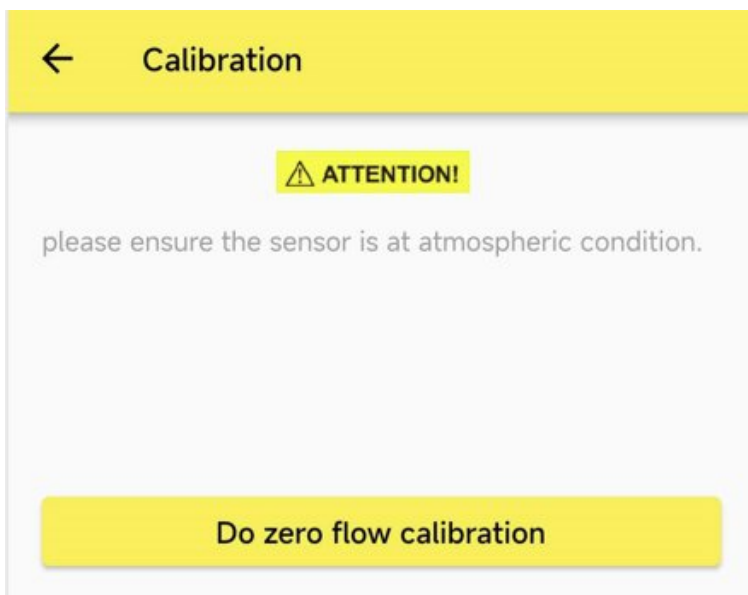

Note: The zero pressure calibration is not required.

9.2.4 Calibration inside Compressor

The S431 received a basic factory calibration before delivery. In case the required straight inlet and outlet sections cannot be met (that is, installation inside compressors or close to compressor outlet), a calibration is needed. Compressor makers can easily perform a calibration in their test stand according to ISO 1217. The steps of calibration are as follows:

1. Launch **S4C-FS**, and select **Settings > User Calibration**.
2. Follow the onscreen instructions to perform the flow calibration.

Below is the GUI of the mobile app for the calibration page:

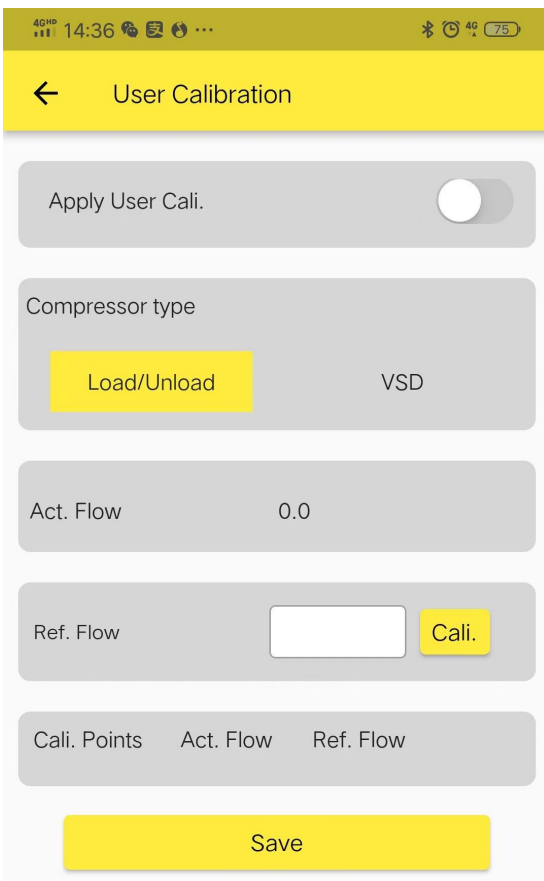

Apply User Calibration

Needs to be activated to perform the calibration.

Compressor type

Select Load/Unload or VSD.

For Load/Unload types, the calibration is offered at full load (1 point). For VSD compressors there are up to 5 calibration points available. It's recommended to select them over the range of 10%...100%. In general 3 points should be sufficient (10%, 50%, 90%).

Act. Flow

This is the flow without the user calibration as it is measured.

Ref. Flow

Manufacturer enters the flow measured by the calibration stand in the factory.

Calibration points are sorted and user can delete any of the calibration points.

Note: Regardless of whether the S431 is installed inside or outside the compressor, it is recommended to send it back to the supplier once a year for calibration or to perform a replacement calibration. Please contact SUTO Service department for this purpose.

In case installation of the S431 inside the compressor, the easiest way for annual calibration is to replace the unit with another flow meter that

has been newly calibrated by SUTO. Since the compressor specific settings have been stored in a cloud database, the operator can download the settings of the replaced unit into the replacement unit through the mobile app. The replaced flow meter can be return to a SUTO service facility for re-calibration and maintenance.

9.2.5 Upload Settings

Flow meter settings can be saved in the cloud server or a local file for a later access in case the S431 need to be replaced in a service case. It is recommended to use this function especially when S431 has been tested and calibrated together with the compressor in the factory or on the site before a flow meter exchange.

Note: This function can only be used by users with special authorizations. Contact SUTO Service Team for authorization.

Follow steps below to upload settings:

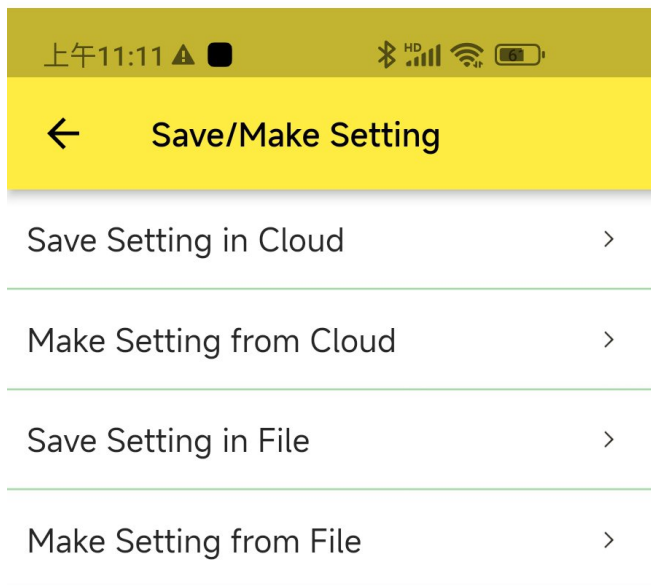

1. Start the S4C-FS App, and enter **Settings** > **Save/Making Setting** page.
2. Click **Save Setting in Cloud** to go into the uploading page.sett

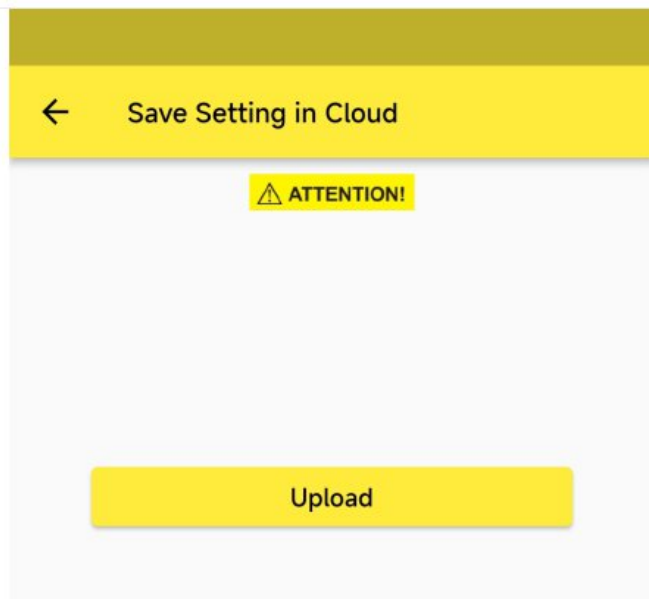

3. Click **Upload**, then settings for the S431 are saved in the cloud server.
4. After uploading successfully, a **SUCCESS** message appears on the lower position of the screen for a few seconds.

Note: Select **Save Setting in File** on **Save/Making Setting** page to save the settings to the mobile phone.

9.2.6 Download Settings

In case the S431 has to be replaced, the settings of the previously installed S431 can be downloaded into the replacement unit from the cloud server or a local file. This is a convenient way to ensure the same settings. User will be asked to enter the serial number of the previous S431 when downloading. If settings of the previous S431 were stored on the cloud server or a local file, it will be downloaded into the new sensor unit.

Note: This function can only be used by users with special authorizations. Contact SUTO Service Team for authorization.

Follow steps below to download settings:

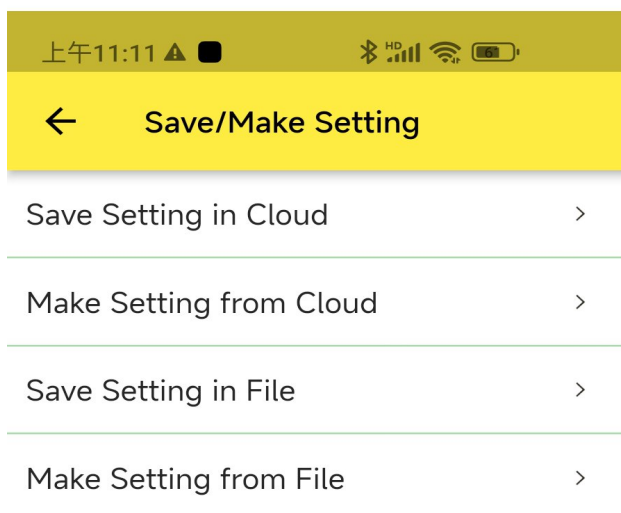

1. Start the S4C-FS App, and enter **Settings** > **Save/Making Setting** page.
2. Click **Make Setting from Cloud** to go into the downloading page.

Note: If settings were saved in a local file, select **Make Setting from File** to download the saved settings.

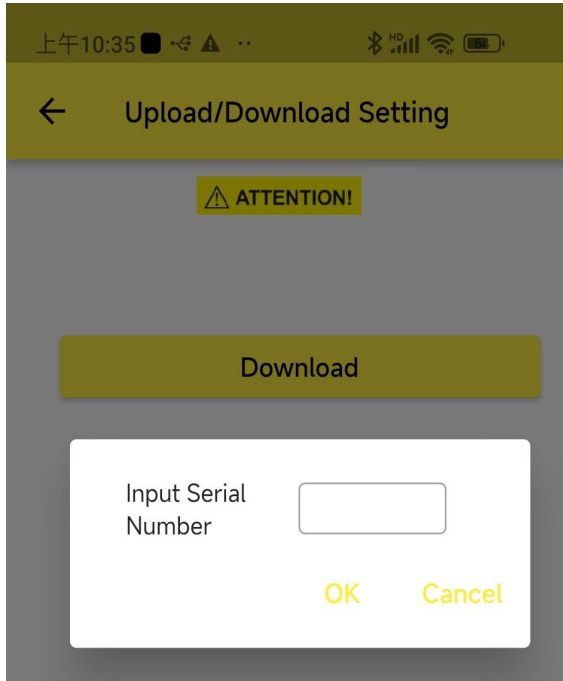

3. Click **Download**, then a pop-up window displays asking for a serial number.
4. Enter the serial number of the previous S431, and click **OK**.

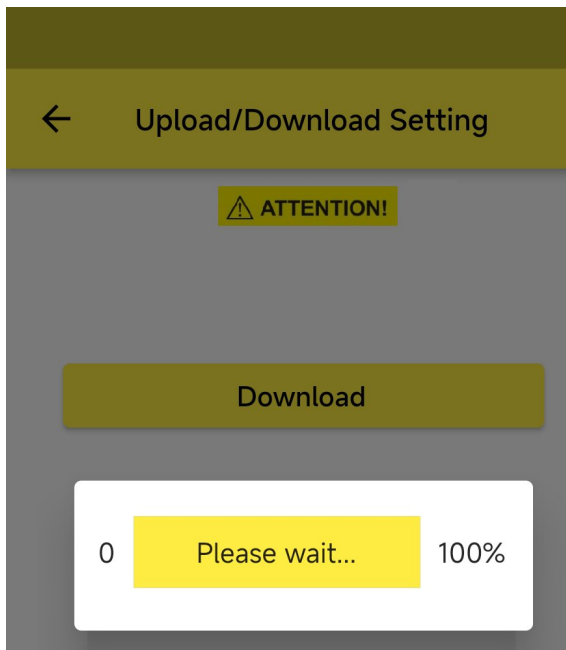

5. The App is downloading the saved settings to the new S431. After downloading successfully, a **SUCCESS** message appears on the lower position of the screen for a few seconds.

10 Signal Outputs

10.1 Analog Output

The S431 can provide an analogue output with the range of 4...20 mA. This output can be scaled to match a desired measuring range. The standard range is the range from 0 to max.

10.2 Pulse Output

The S431 sends out one pulse per a consumption unit by default. This pulse output can be connected to an external pulse counter to count the total consumption. The number of m^3 per second are accumulated and indicated after one second. The pulse length depends on consumption rate.

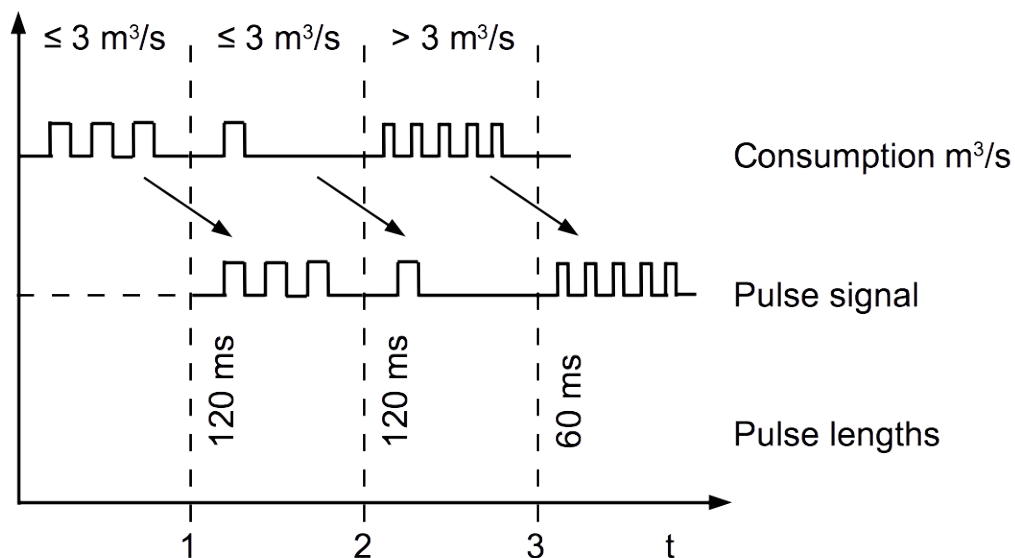

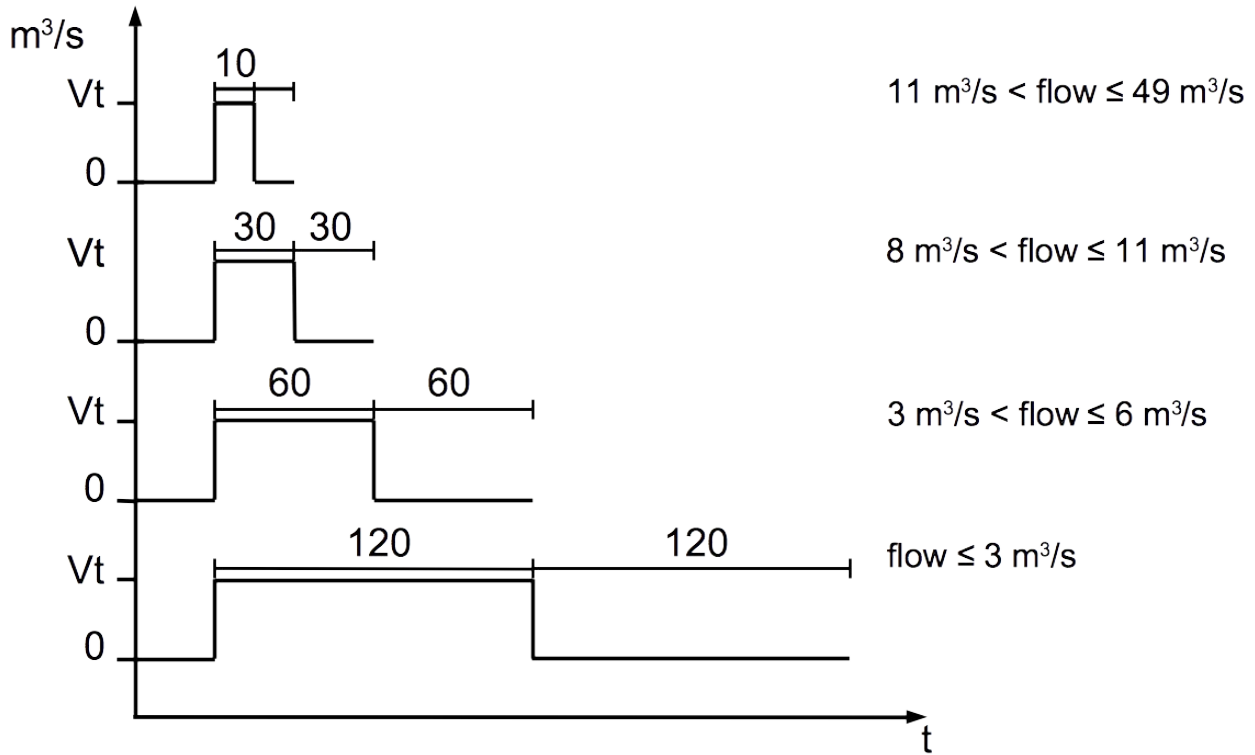

If the flow is higher than 50 m³/s, l/s of ft³/s, the S431 cannot output the pulses with default settings (one pulse per a consumption unit).

In this case, you can set the pulse to 1 pulse per 10 consumption units or 1 pulse per 100 consumption units using by the S4C-FS service app or a connected display.

For example, with the setting of 1 pulse per 10 m³, the S431 sends one pulse each 10 m³.

Example:

Volume flow [m ³ /h]	Pulse length [ms]	Max. consumption [m ³]
≤ 10,800	120	10,800
> 10,800	60	28,800
> 28,800	30	57,600

10.3 Modbus Interface

The default settings of the Modbus interface are as follows:

Mode	RTU
Baud rate	19200
Device address	Last two digits of the serial number
Framing / parity / stop bit	8, N, 1
Response time	1 second
Response delay	0 ms
Inter-frame spacing	7 char

Response message that the device returns to the master:

- Function code: 03

The information of the byte order is shown in the table below:

Byte Order	Sequence				Data Type
	1st	2nd	3rd	4th	
1-0-3-2	Byte 1 (MMMMMMMM*)	Byte 0 (MMMMMMMM *)	Byte 3 (SEEEEEEE)	Byte 2 (EMMMMMMM *)	FLOAT
1-0-3-2	Byte 1	Byte 0 LSB	Byte 3 MSB	Byte 2	UINT32 INT32
1-0	Byte 1 MSB	Byte 0 LSB	---	---	UINT16 INT16
1-0	Byte 1 XXX *	Byte 0 DATA	---	---	UINT8 INT8

* S: Sign, E: Exponent, M: Mantissa, XXX: no value

Explanations of MSB and LSB

MSB MSB refers to Most Significant Byte first, which follows the Big-Endian byte order.

For example, if the main system follows the MSB first order:

When the 4-byte floating number, in the order of Byte1-Byte0-Byte3-Byte2, is received from the slave (sensor), the master must change the byte order to Byte3-Byte2-Byte1-Byte0 for the correct display of the value.

LSB LSB refers to Least Significant Byte first, which follows the Little-

Endian byte order.

For example, if the main system follows the LSB first order:

When the 4-byte floating number, in the order of Byte1-Byte0-Byte3-Byte2, is received from the slave (sensor), the master must change the byte order to Byte0-Byte1-Byte2-Byte3 for the correct display of the value.

Remarks: Modbus communication settings as well as other settings can be changed by the service App **S4C-FS** or the optional sensor display.

Available measurement channels:

Channel description	Resolution	Format	Length	Register address
Medium temperature	0.1	FLOAT	4-Byte	0
Medium pressure	0.010	FLOAT	4-Byte	2
Actual velocity	0.1	FLOAT	4-Byte	4
Flow	0.1	FLOAT	4-Byte	6
Consumption	1.0	UINT32	4-Byte	8
System status	N/A	UINT32	4-Byte	24

System status

The device provides the device statuses via Modbus as well. The 32-bit data information is read as single bit. The meanings of these bits are described as follows.

Bit	Description	Bit	Description
2	Measurement over range	9	Pressure sensor broken
3	Temperature over range	10	Temperature sensor broken
4	Pressure over range	11	NTC broken
5	Pulse over range	15	Flow direction 0: standard 1: reversed
6	Calibration overdue	16	BT module connected
8	Differential pressure sensor broken		

10.4 Connection between S431 Outputs and Customer Equipment

This section provides figures to show how outputs supported by the S431 connect with the customer equipment.

In the following figures, the SUTO instrument indicates the S431.

4 ... 20 mA analog output (3-wire)

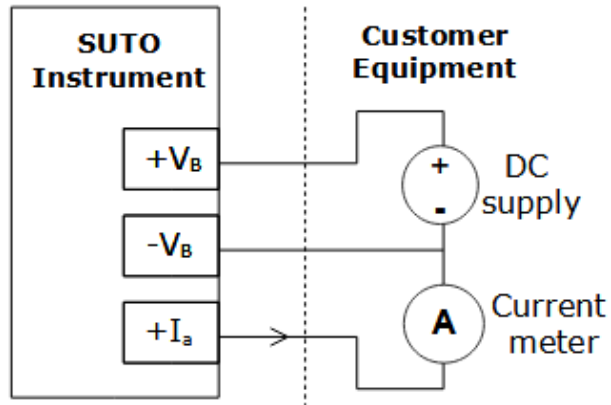

Pulse output (passive)

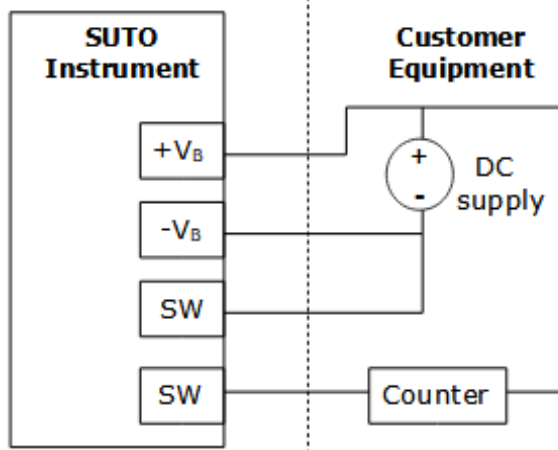

Modbus/RTU output

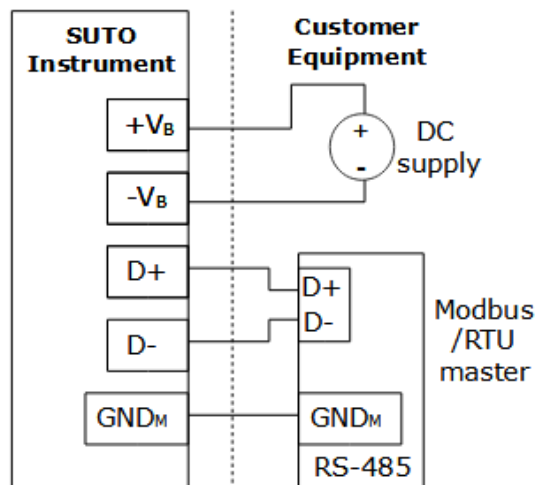

11 Maintenance

To clean the flow meter it is recommended to use distilled water or isopropyl alcohol only. If the contamination can not be removed, you must send the flow meter to the manufacturer for inspection.

12 Disposal or Waste



Electronic devices are recyclable material and do not belong in the household waste.

The device, the accessories and its packings must be disposed according to your local statutory requirements.

The dispose can also be carried by the manufacturer of the product. Please contact the manufacturer for details.

SUTO iTEC GmbH

Grißheimer Weg 21
D-79423 Heitersheim
Germany

Tel: +49 (0) 7634 50488 00
Email: sales@suto-itec.com
Website: www.suto-itec.com

SUTO iTEC (ASIA) Co., Ltd.

Room 10, 6/F, Block B, Cambridge Plaza
188 San Wan Road, Sheung Shui, N.T.
Hong Kong

Tel: +852 2328 9782
Email: sales.asia@suto-itec.com
Website: www.suto-itec.com

SUTO iTEC Inc.

5460 33rd St SE
Grand Rapids, MI 49512
USA

Tel: +1 (616) 800-7886
Email: sales.us@suto-itec.com
Website: www.suto-itec.com

All rights reserved ©

Modifications and errors reserved

S431 OEM_V2_IM_EN_V2025-1