

Instruction and Operation Manual

S601

Stationary Compressed Air Purity Monitor



Dear Customer,

Thank you for choosing our product.

Please read the manual in full and carefully observe operating instructions stated before you start up the device. The manufacturer cannot be held liable for any damage that occurs as a result of non-observance or non-compliance with this manual.

Should the device be tampered with in any manner other than a procedure which is described and specified in the manual, the warranty is void and the manufacturer is exempt from liability.

The device is destined exclusively for the described application.

SUTO offers no guarantee for the suitability for any other purpose. SUTO is also not liable for consequential damage resulting from the delivery, capability or use of this device.

Revision: 2025-2-3



Last modifications: December, 2025

Table of Contents

1 Safety Instructions.....	5
2 Registered Trademarks.....	8
3 Application.....	9
4 Features.....	9
5 Technical Data.....	10
5.1 General Data.....	10
5.2 Electrical Data.....	11
5.3 Accuracy.....	11
5.4 Relay Module (Optional)	12
6 Dimensions.....	13
7 Installation on Site.....	14
7.1 Select Installation Location.....	14
7.2 Mount on the Wall.....	15
7.3 Electrical Connections.....	16
7.3.1 Power Supply.....	16
7.3.2 RS-485 Networking (Modbus/RTU).....	17
7.3.3 TCP/IP Networking (Modbus/TCP).....	18
7.3.4 Alarm Outputs.....	18
7.4 Compressed Air Connection.....	20
7.5 Connect Modbus/RTU Sensors/Devices to a Master.....	21
7.5.1 Modbus/RTU Cable Length.....	21
7.5.2 Modbus/RTU Wiring and Cable Type.....	22
7.5.3 Daisy-Chain using RS-485 Splitter.....	22
7.5.4 Topology of Modbus/RTU Daisy-Chain.....	23
8 Setup.....	24
9 Operations and Configurations.....	24
9.1 Main Screen.....	25
9.1.1 Quick Buttons and Icons.....	25
9.1.2 Icons in the Status Bar.....	25
9.2 Value Screen.....	26
9.3 Graphic Screen.....	27
9.4 Menu.....	27
9.4.1 Sensor Settings.....	28
9.4.2 Alarm Setting.....	29
9.4.3 Logger Setting.....	30
9.4.4 Files.....	31
9.4.5 Service Info	31
9.4.6 System Setting.....	32
9.4.7 Communication.....	33
9.5 Configuring S601 using S4C-Display.....	33
9.5.1 RS-485 Settings.....	34
9.5.2 Ethernet Settings.....	35
9.5.3 Modbus Interface.....	36
10 Software Installation.....	38
11 Optional Accessories.....	38

12 Maintenance.....38
13 Disposal or Waste.....39
14 Calibration.....39
15 Warranty.....39

1 Safety Instructions

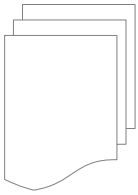

Please check if this instruction manual matches the product type.

Please observe all notes and instructions indicated in this manual. It contains essential information which must be observed before and during installation, operation and maintenance. Therefore this instruction manual must be read carefully by the technician as well as by the responsible user / qualified personnel.

This instruction manual must be available at the operation site of the flow sensor at any time. In case of any obscurities or questions, regarding this manual or the product, please contact the manufacturer.



WARNING!

Compressed air!

Any contact with quickly escaping air or bursting parts of the compressed air system can lead to serious injuries or even death!

- Do not exceed the maximum permitted pressure range. (See sensors label.)
- Only use pressure tight installation material.
- Avoid that persons get hit by escaping air or bursting parts of the instrument.
- The system must be pressure less during maintenance work.

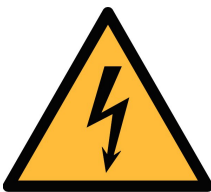

WARNING!

Voltage used for supply!

Any contact with energized parts of the product, may lead to an electrical shock which can lead to serious injuries or even death!

- Consider all regulations for electrical installations.
- The system must be disconnected from any power supply during maintenance work.

Laser Safety Information



This product contains a laser-based counter that is Class 1 product (as defined by 21 CFR, Subchapter J of the Health and Safety Act of 1968) when used under normal operation and maintenance. Service procedures on the counter can result in exposure to invisible radiation. Service should be performed only by factory-authorized personnel.



ATTENTION!

Permitted operating parameters!

Observe the permitted operating parameters. Any operation exceeding this parameters can lead to malfunctions and may lead to damage on the instrument or the system.

- The instrument must be operated within or better than compressed air quality Class 4.5.4 according to the ISO8573-1. If the air quality cannot reach the specified Class, the device may show wrong measurement values or even may get damaged.
- Do not exceed the permitted operating parameters.
- Make sure the product is operated in its permitted limitations.
- Do not exceed or undercut the permitted storage and operating temperature and pressure.
- The product must be maintained and calibrated frequently, at least annually.

General safety instructions

- It is not allowed to use the product in explosive areas.
- Please observe the national regulations before/during installation and operation.

Remarks

- It is not allowed to disassemble the product.
- Always check the compressed air connectors in terms of stability and tightness.

**ATTENTION!**

Measurement values can be affected by malfunction!

The product must be installed properly and frequently maintained. Otherwise it may lead to wrong measurement values, which can lead to wrong results.

- Always observe the direction of the flow when installing the sensor. The direction is indicated on the housing.
- Do not exceed the maximum operating temperature at the sensors tip.
- Avoid condensation on the sensor element as this will affect the accuracy enormously.

Storage and transportation

- Make sure that the transportation temperature is between -10 ... +50°C.
- For transportation it is recommended to use the packaging which comes with the sensor.
- Please make sure that the storage temperature of the sensor is between -10 ... +50°C.
- Avoid direct UV and solar radiation during storage.
- For the storage the humidity must be <90%, no condensation.

**ATTENTION!**

Equipment may get damaged!

Please make sure, that your measuring point is free of excessive contamination/dirt. This should be maintained before every measurement.

- Observe the measuring point always before measurement if it is free of contamination like water drops, oil drops or other rough contamination.
- Should water hit the inner electronics, the sensors could be seriously damaged.
- Check your measurement point with the enclosed test kit.

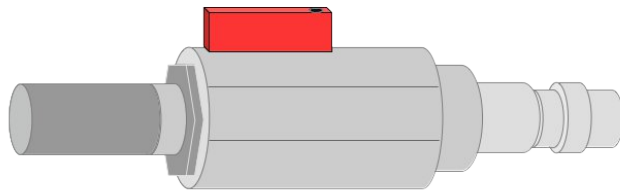

2 Registered Trademarks

SUTO®	Registered trademark of SUTO iTEC
MODBUS®	Registered trademark of the Modbus Organization, Hopkinton, USA
HART®	Registered trademark of the HART Communication Foundation, Austin, USA
Android™, Google Play	Trademarks of Android™, Google Play

3 Application

The S601 Stationary Compressed Air Purity Monitor is a compact wall-mounted device that measures and records three major quality parameters of compressed air (particle quantity, dew point and temperature).

The S601 is mainly used in industrial environments, and not developed to be used in explosive areas.

4 Features

- All-in-one device measures particle concentration, dew point and oil vapor
- Measures additionally the temperature and pressure
- Open protocol outputs enable integration with your management system
- Modbus/RTU (RS-485) and Modbus/TCP (Ethernet) included
- Compact design and easy setup
- Compressed air connection via 6 mm tube
- Integrated data logger saves data for later analysis
- Dew point measurement from -100 ... +20°C Td
- Oil vapor measurement from 0.001... 5.000 mg/m³
- The detection limit of oil vapor down to 0.001 mg/m³
- Particle measurement in two versions:
 - A1260: $0.3 < d \leq 5.0 \mu\text{m}$
 - A1263: $0.1 < d \leq 5.0 \mu\text{m}$

5 Technical Data

5.1 General Data

CE FC			
Parameter	Measuring parameter	Range	Reference
	Particle	Option A1260: 0.3 < d ≤ 0.5 μm 0.5 < d ≤ 1.0 μm 1.0 < d ≤ 5.0 μm	Annex 1 / DIN 14644
		Option A1263: 0.1 < d ≤ 0.5 μm 0.5 < d ≤ 1.0 μm 1.0 < d ≤ 5.0 μm	
	Dew point	-100 ... +20°C Td	DIN 8573
	Oil vapor	0.001 ... 5.000 mg/m ³	ZLG/AIM 07120604
	Pressure	0.3 ... 1.5 MPa	DIN 1301
	Temperature	0 ... +50°C	DIN 60751
	Reference settings	ISO 1217, 20°C 1000 mbar	
Measurement principle	Parameter	Principle	
	Particle quantity	Laser optical detection	
	Dew point	Polymer humidity sensor, oscillating crystal	
	Oil vapor	PID	
Resolution of oil vapor sensor	0.001 mg/m ³		
Data logger	Internal, 100-million values		
Interface	USB Ethernet (Modbus/TCP) RS-485 (Modbus/RTU)		
Output	Two internal Relays One 8-channel relay module (optional)		

Medium	Compressed air, non corrosive components
Humidity of the medium	< 40% rH, non condensation
Temperature of the medium	0 ... +50°C
Operation pressure	0.3 ... 1.5 MPa / 43.5 ... 217.6 psig
UV lamp lifetime (oil vapor)	9,000 working hours
Housing material	Sheet steel, powder-coated on the outside
Protection class	IP55
Dimension	Please observe the drawings on the next page
Display	5" graphics color display, 800 x 480 Pixel with touch screen interface
Weight	15 kg

5.2 Electrical Data

Power supply	Input: 100 ... 240 VAC, 50/60 Hz, 50 VA
--------------	---

5.3 Accuracy

Particle (Per ISO 21501-4)	
Option A1260	30...70% of $d > 0.3 \mu\text{m}$ 90... 110% of $d \geq 0.45 \mu\text{m}$
Option A1263	30...70% of $d > 0.1 \mu\text{m}$ 90... 110% of $d \geq 0.3 \mu\text{m}$
Dew point	$\pm 1 \text{ }^\circ\text{C Td}$ (0 ... 20 $^\circ\text{C Td}$) $\pm 2 \text{ }^\circ\text{C Td}$ (-70 ... 0 $^\circ\text{C Td}$) $\pm 3 \text{ }^\circ\text{C Td}$ (-100 ... -70 $^\circ\text{C Td}$)
Oil vapor	5% of value $\pm 0.003 \text{ mg/m}^3$
Temperature	$\pm 0.2 \text{ K}$
Pressure	$\pm 0.08 \text{ bar}$

5.4 Relay Module (Optional)

Power input	10 ... 48 VDC
Power consumption	1.8 W @ 24 VDC
Number of output channels	8
Contact rating (Resistive)	0.5 A @ 120 VAC 0.25 A @ 240 VAC 1 A @ 30 VDC 0.3 A @ 110 VDC
Breakdown voltage	750 VAC (50/60 Hz)
Total switching time	10 ms
Maximum operating	50 operations / min
Mounting	Rail mounted

6 Dimensions

Dimensions in mm:

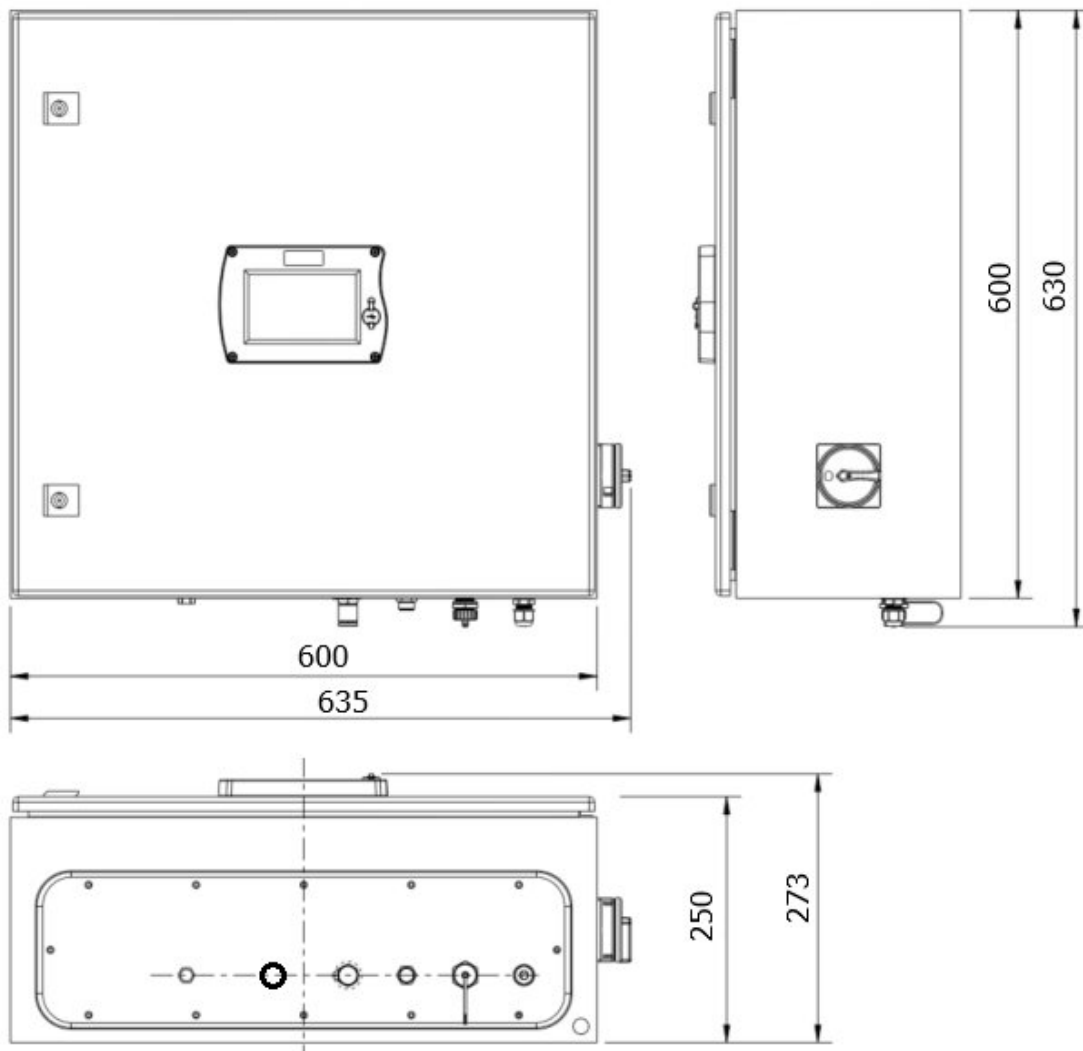

7 Installation on Site

Please make sure that all components listed below are included in your package.

Qty.	Description	Item No.
1	S601 Stationary Compressed Air Purity Monitor in a wall mountable cabinet	D500 0601
1	USB OTG memory stick	A554 0087
1	Operation and instruction manual	No P/N
1	Purge filter for pre-measurement (test kit)	A554 0604
1	6 mm Teflon hose with quick connector on one end and compressed air coupling on the other end, 1.5 m	A554 3316
1	Depending on orders: M12 connector or M12 cable (5 or 10 m)	Connector: C219 0059 Cable: A553 0104 or A553 0105
1	M12 connector	C219 0059
1	Certificate of calibration	No P/N

If you need replacement materials from the list above or need further useful accessories, please contact the manufacturer or your local distributor.

7.1 Select Installation Location

The device needs to be set up next to the measuring point.

The air supply tube should not be bended too strongly and should be installed with a big curve radius.



ATTENTION!

The device is designed to be operated indoors only

7.2 Mount on the Wall

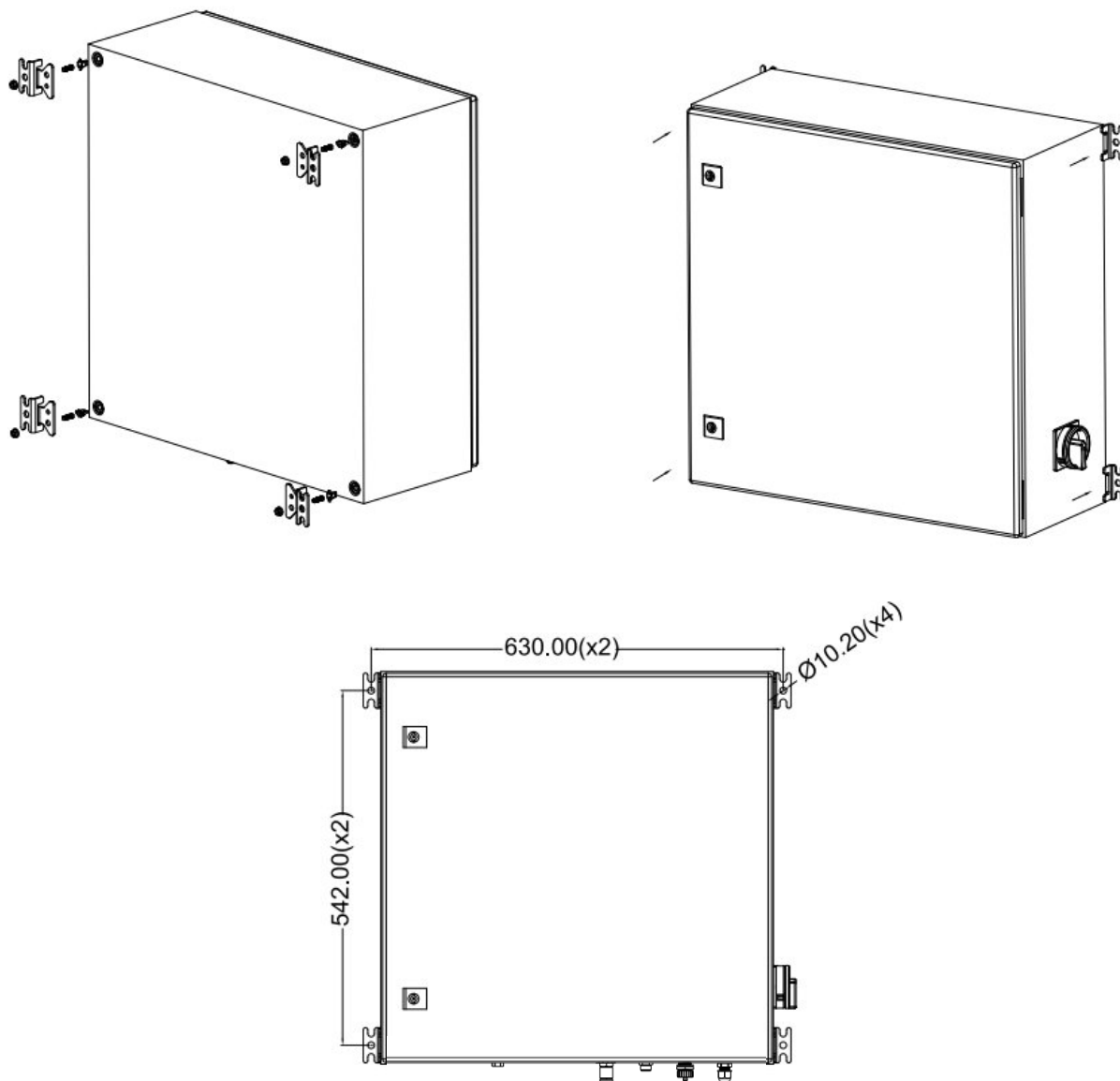

7.3 Electrical Connections

The S601 provides the following electrical connectors:

- A power supply connector (The cable is inserted through a PG plug and wires are connected to the internal screw terminals.)
- An M12 RS-485 connector: To connect S601 to a RS-485 network
- A RJ-45 Ethernet connector: To connect S601 to a TCP/IP network
- A PG plug for the relay output. The relays are provided inside the S601 cabinet.

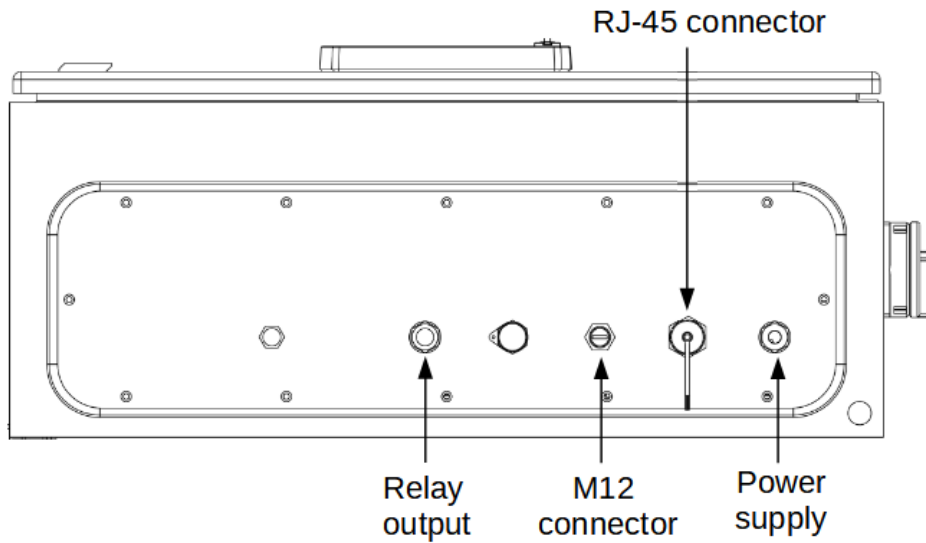

S601 bottom view

7.3.1 Power Supply

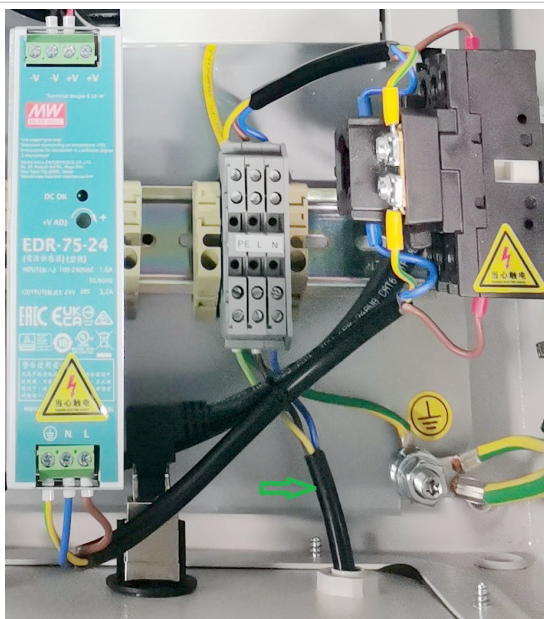

The power cable for the 230 VAC is connected to the terminals inside of the cabinet, as shown in the picture on the left.

**ATTENTION!**

Please observe voltage ranges and power levels!

7.3.2 RS-485 Networking (Modbus/RTU)

Through the M12 connector at the bottom, the S601 can be connected to the RS-485 network over the Modbus/RTU protocol.

The RS-485 network requires a termination resistor at both far ends of the RS-485 bus. Please set them up correctly.

The RS-485 networking uses the following 3 pins in the M12 connector. The pin functions are described below.

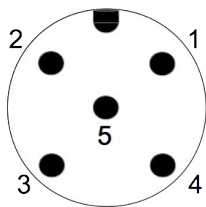

Pin No.	Assignment	Function
4	Data +	Data + signal
5	Data -	Data - signal
1	GND RS-485	Ground of RS-485

RS-485 cable

Only cables according to the recommendations of EIA 485 standard should be used. A maximum of 30 devices may be connected to one segment. The bus cable must be laid at a distance of at least 20 cm from other cables. It should be laid in a separate, conductive, and earthed cable trunk. It must be ensured that no potential differences occur between the individual devices on the bus.

RS-485 cable specification

- Impedance: 135 – 165 Ohm @ 3 to 20 Mhz
- Cable capacity: < 30 pF/m
- Cable diameter: > 0.64 mm
- Cross section: > 0.34 mm², conforms to AWG 22
- Loop resistance: < 110 Ohm/km
- Screening: Cu shielding braid or shielding braid and shielding foil
- Outer diameter for power and sensor cable: 4.5 ... 8 mm

7.3.3 TCP/IP Networking (Modbus/TCP)

Through the RJ-45 connector at the bottom, the S601 can be connected to the TCP/IP network over the Modbus/TCP protocol.

Remove the protection cap and plug in the network cable (RJ-45).

7.3.4 Alarm Outputs

7.3.4.1 Built-in Relays

The S601 provides two relays for alarm outputs (230 VAC, 3 A) in the S601 cabinet.

The relays are pre-wired and the relay wires are connected to terminals inside the cabinet, as shown in the picture below.

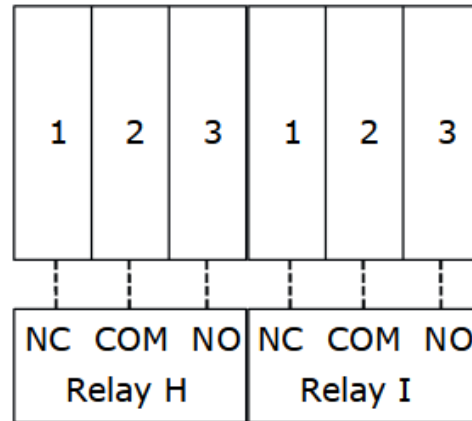
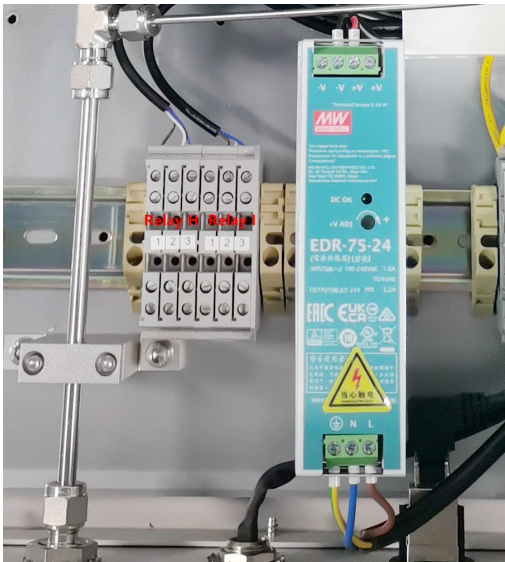

The example on the right shows a DC alarm unit wiring.

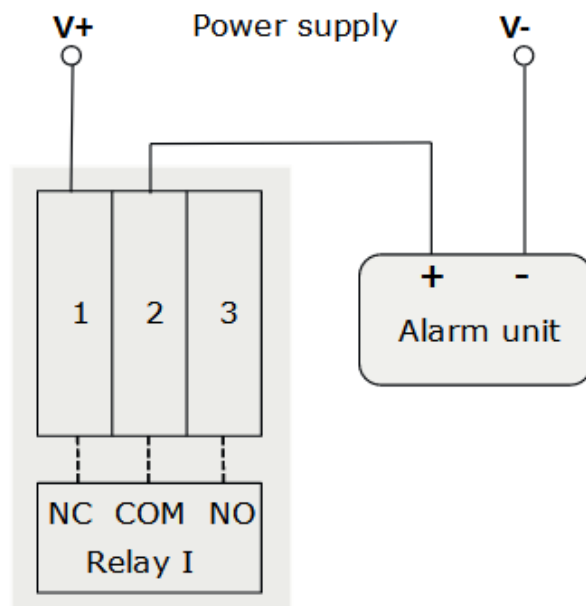

7.3.4.2 Optional Relay Module

If more relay outputs are required, an extended relay module is available. The relay module provides up to 8 relay outputs.

In the relay module, the RL0 ~ RL7 are relay terminals. All relays on the module can be configured as required to control external devices. For configurations, see the section 9.4.2.

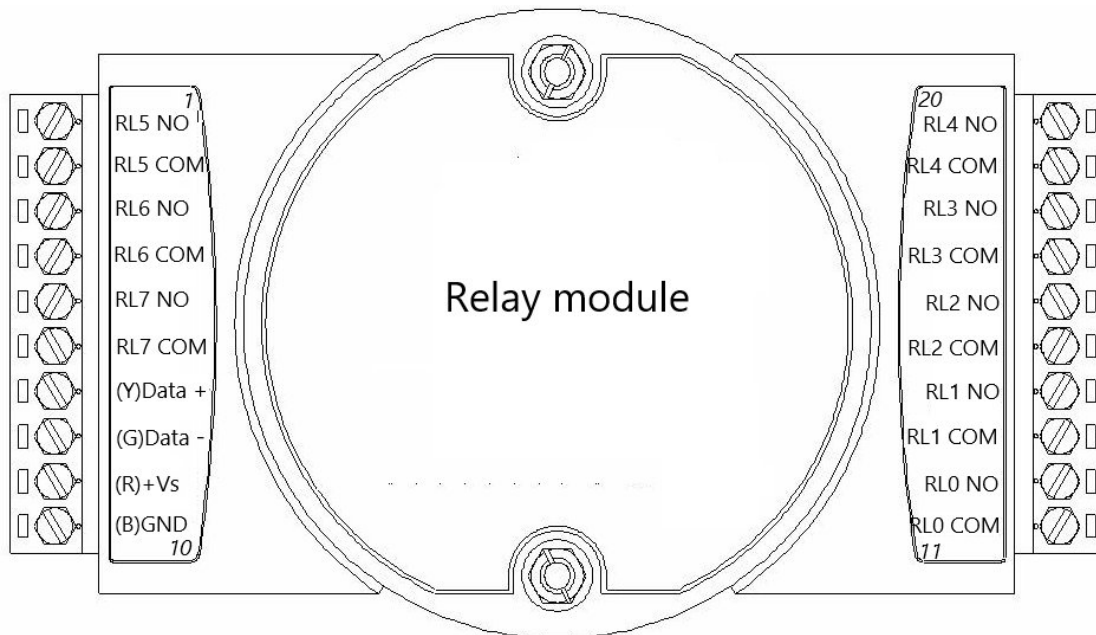

The example below shows a DC alarm unit wiring.

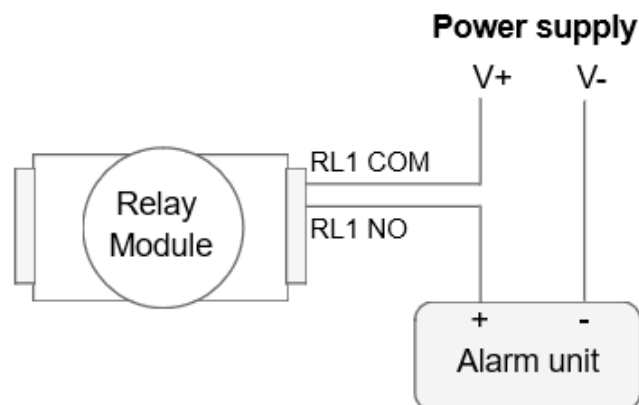

If you purchase the S601 with the relay module, the module is pre-installed in the S601 chassis with all necessary connections completed, and you only need to connect the external alarm device to the relay.

If you purchase the relay module for your existing S601, you can contact SUTO service team for detailed installation procedures.

7.4 Compressed Air Connection

The S601 offers a compressed air inlet and an outlet at the bottom of the cabinet, next to the electrical connectors.

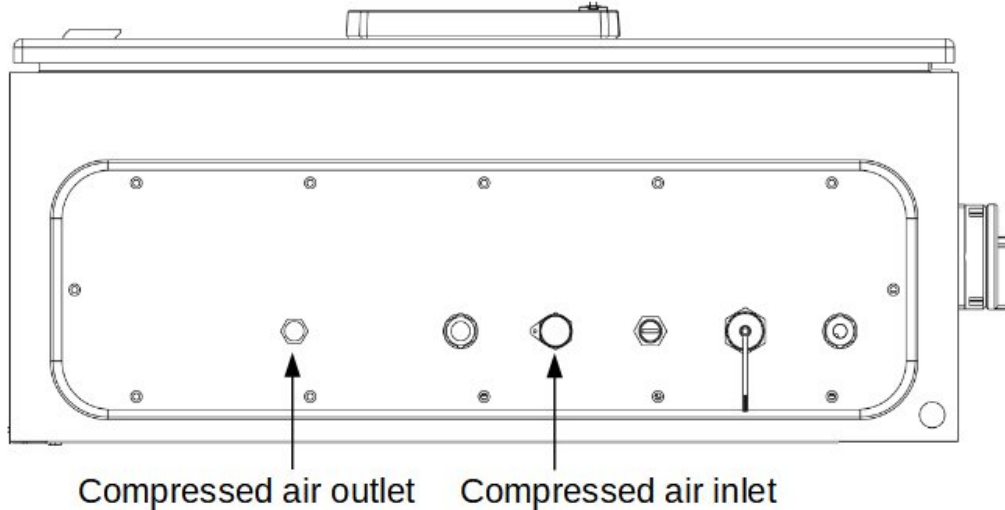

S601 bottom view

Installation precautions



ATTENTION!

Permissible pressure!

Please observe the maximum permissible incoming pressure. It must be in between 0.3 and 1.5 MPa. If the pressure exceeds, it will damage the device. If the pressure is too low, the volume flow will not be high enough, which will lead to wrong results.



ATTENTION!

Before you connect the device to your point of measurement, make sure that there is no rough contamination such as water / oil drops or heavy dust. This could damage the sensor units.

Please use the purge filter test kit to check the contamination.

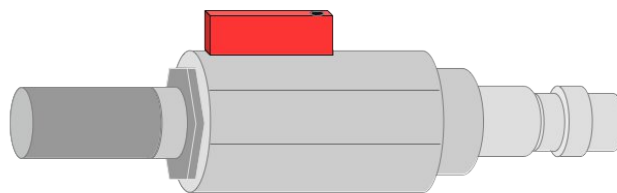

To check the measuring point, do the following:

1. Connect the purge filter test kit onto your measuring point.
2. Open the purge valve on the test kit and purge some air for a short period.
3. Check the filter in the test kit for high contamination of water, oil or dust.
4. If the filter is contaminated severely, stop using the S601 to measure because this may lead to serious damage. In case you are not sure, please contact the manufacturer.

7.5 Connect Modbus/RTU Sensors/Devices to a Master

Sensors and devices with a Modbus/RTU output can be connected to a Modbus master device. This master can be either SUTO displays and gateways or any third-party Modbus/RTU master.

See below specifications of the Modbus/RTU connections.

7.5.1 Modbus/RTU Cable Length

A Modbus/RTU bus line has limitations which shall not be exceeded, otherwise the communication might not be stable.

- The maximum total bus length must not exceed 1200 m.
- The stub length to each node must not exceed 30 cm.

See the picture below for details.

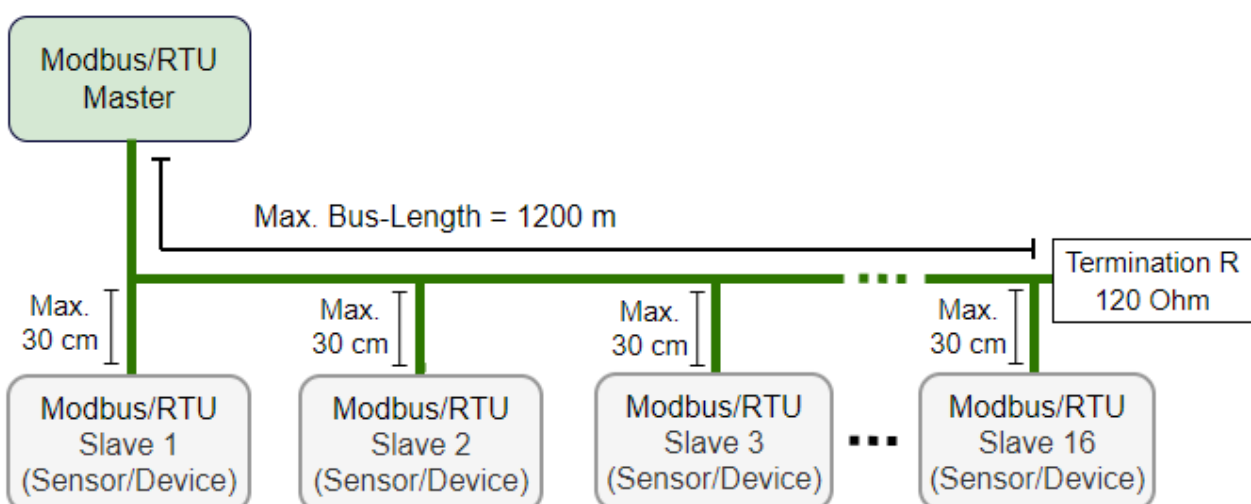

7.5.2 Modbus/RTU Wiring and Cable Type

To ensure a stable communication a twisted-pair bus cable must be chosen to set up the Modbus/RTU communication.

- Bus-cable specifications must follow the EIA485 Standard, must be twisted pair and shielded, for example 2 x 2 x 0.22 mm², Li-2YCY (A553 0123).
- The shield must be connected at one end to the master GND connection.
- At the end of the bus, a 120 Ohm resistor should be placed a termination resistor.

See the below picture for details.

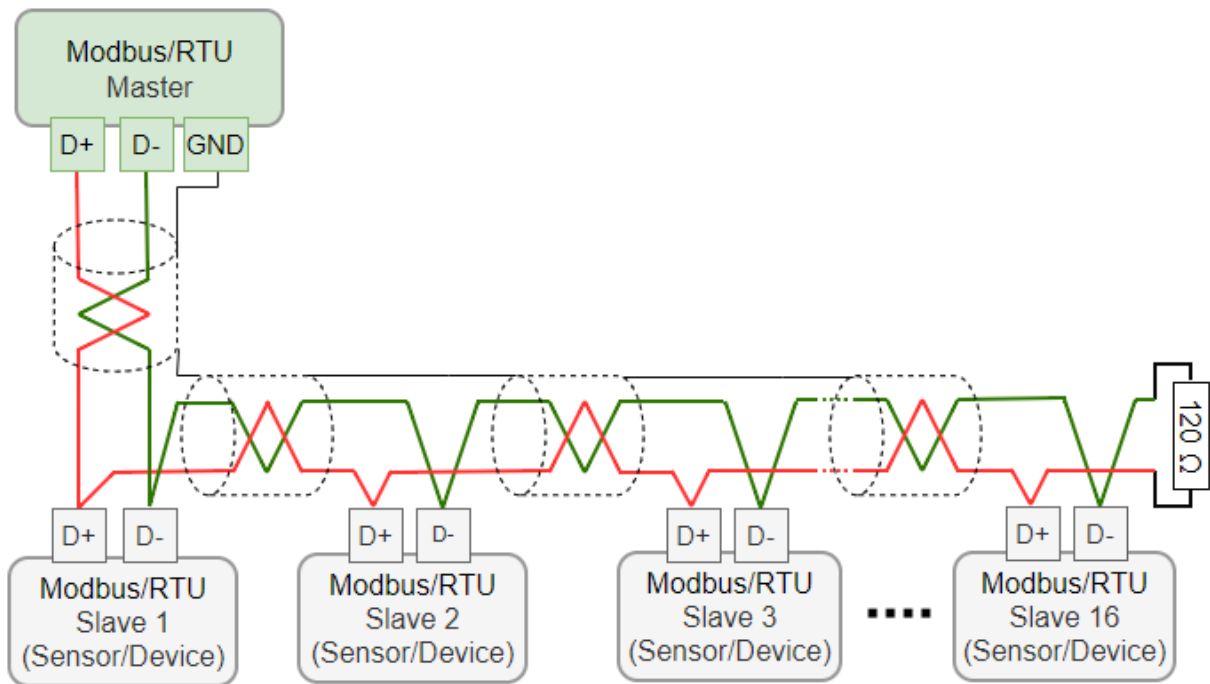

7.5.3 Daisy-Chain using RS-485 Splitter

SUTO devices with M12 connectors can be easily connected in a Modbus/RTU daisy-chain using a M12 RS-485 splitter (A554 3310). Furthermore this allows to easily place the M12 termination resistor (C219 0055) at the last splitter in the bus-chain.

Connect Modbus/RTU slaves with M12 connectors to a daisy-chain using M12 RS-485 splitters.

The M12 RS-485 splitter (A554 3310) comes with two M12 connectors to easily wire the chain.

7.5.4 Topology of Modbus/RTU Daisy-Chain

The recommended bus topology is to connect devices as a daisy-chain, as shown in the figure in section 7.5.1 Modbus/RTU Cable Length. Other connection topologies are not recommended and must be avoided.

Avoid a connection of slaves to the master in ring or star topology.

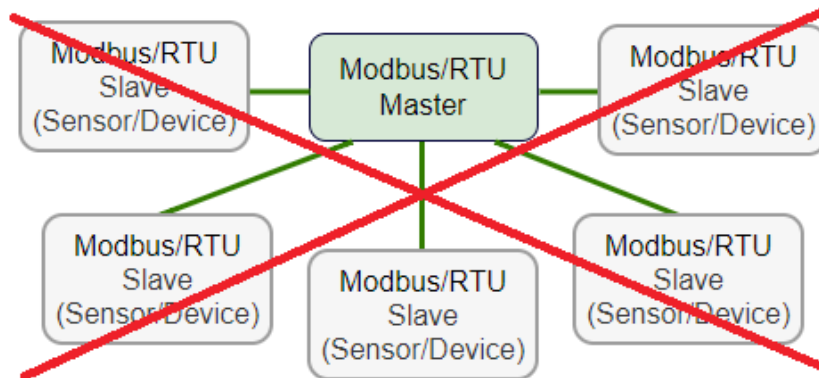

Avoid a star topology

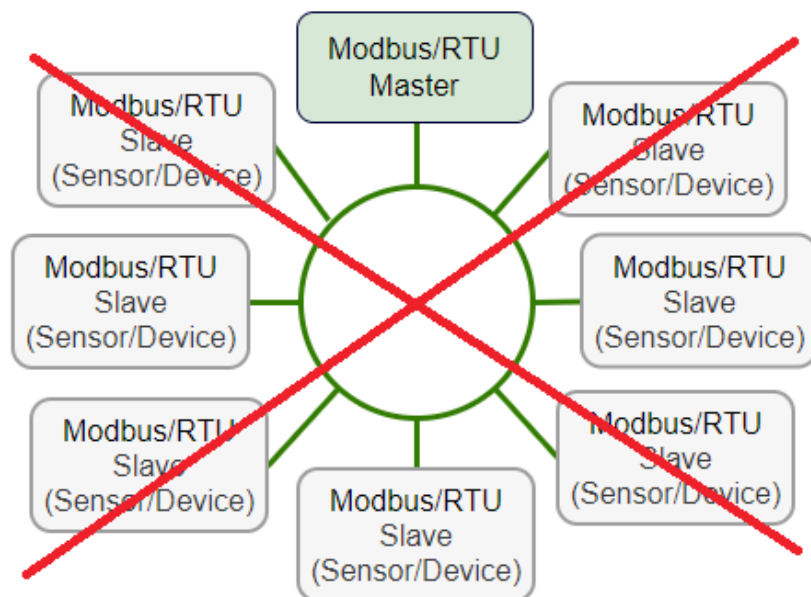

Avoid a ring topology

8 Setup

The S601 is configured ex-work and ready to measure out of the box. The setup settings are saved in the device and will not be lost even after a power failure.

To ensure an accurate measurement, before measurement, configure the altitude where the device is placed. The device also enables you to change the ex-work settings. For more information, see section 9.4.



ATTENTION!

If you have problems setting up your device, feel free to contact the manufacturer or your local dealer for assistance.

If a power failure occurs during the measurement, the measurement data will not be saved.

9 Operations and Configurations



When the S601 is powered on, the initialization screen is displayed with an active progress bar.

During the initialization, the device configures the sensors and runs initialization routines.

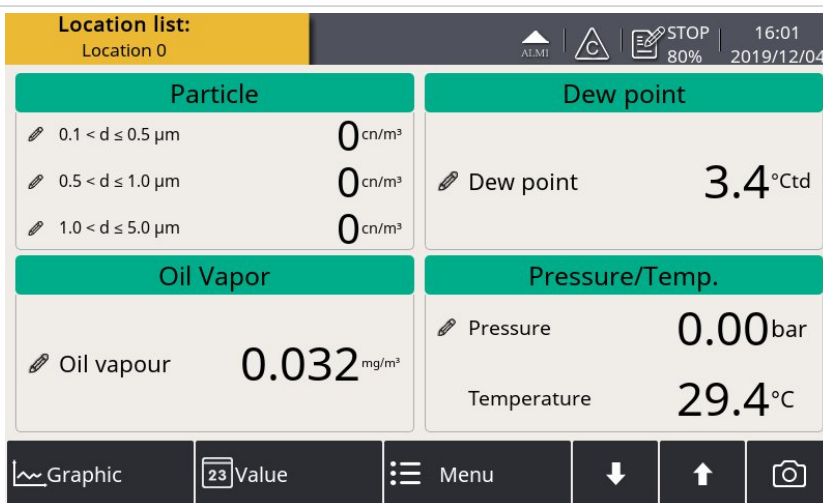

The value screen appears, as shown in the left.

9.1 Main Screen

The following figure shows the main screen in the value view.

Status bar

Display area

Quick buttons and icons

9.1.1 Quick Buttons and Icons

	To switch to the graphic view of measurement data
	To switch to the value view of measurement data
	To access the operation menus
	To scroll down and up the screen
	To take a screenshot

9.1.2 Icons in the Status Bar

	USB stick connected. Press the icon to disconnect the stick.		System errors occur. Press this icon to get further information.
	Type of the connected sensor does not match with the sensor type configured in the device.		Sensor unit is not matching with configuration.
	Logger status		RTC backup battery status
	Calibration is expired. Please contact the manufacturer or your local dealer.		Alarm triggered

9.2 Value Screen

Shows the measured values in real time.

The screenshot displays the Value Screen interface. At the top, a yellow bar shows 'Location list: Location 0'. To the right, there are status icons: an alarm bell (ALM), a warning triangle (C), and a 'STOP 80%' indicator. The time is 16:01 and the date is 2019/12/04. The main area is divided into four panels:

- Particle:** Shows three categories: 0.1 < d ≤ 0.5 μm (0 cn/m³), 0.5 < d ≤ 1.0 μm (0 cn/m³), and 1.0 < d ≤ 5.0 μm (0 cn/m³).
- Dew point:** Shows a reading of 3.4 °Ctd.
- Oil Vapor:** Shows a reading of 0.032 mg/m³.
- Pressure/Temp.:** Shows Pressure at 0.00 bar and Temperature at 29.4 °C.

At the bottom, there is a navigation bar with icons for Graphic, Value (selected), Menu, and navigation arrows (down, up, camera).

To view the value screen, press **Value** in the bottom bar.

Remark: During the first five minutes, the S601 automatically performs a purge process to ensure any remaining particles in the system are blown out. During this period, the counting numbers on the *Particle* pane appear green and blink.

9.3 Graphic Screen

Shows the dynamic graphs of all measurements. To view the graphic screen, press **Graphic** in the bottom bar.

The graphic view is pre-configured in the factory. You can view the S601 measurement graph without configuring anything. In case that you want to manipulate the graph, follow the instructions indicated in the following figure.

The screenshot shows the 'Graphic' screen with a line graph of measurements over time. The top status bar shows 'Remaining time: N/A', a battery icon, 'STOP 76%', and the date '2019/08/19'. The graph displays several data series in different colors (red, yellow, green, blue, purple, pink) against a white background with a red zero line. The Y-axis is labeled 'cn/ft³' and the X-axis shows time from 19:19:50 to 19:20:20. A right-hand panel lists channel settings for various parameters like 'Dew point', 'Oil vapour', and 'Temperature'. A bottom navigation bar includes 'Graphic', 'Value', 'Menu', and navigation arrows. Annotations with arrows point to specific features: 'Touch Y-axis to set scaling' points to the Y-axis; 'Touch X-axis to define the viewing period' points to the X-axis; 'To scroll time' points to the right arrow in the bottom bar; 'To bring you back to the home page' points to the home icon in the bottom bar; and 'Settings related to a channel' points to the channel list on the right, which includes instructions: 'Touch once on a channel to select the channel's scaling as the Y axis.', 'Touch twice on a channel to hide its graph.', and 'Long touch to change the channel settings such as curve color.'

9.4 Menu

Enables you to change the S601 settings.

The screenshot shows the 'Menu' screen with a grid of eight circular icons representing different settings: 'Sensor setting', 'Location setting', 'Alarm', 'Logger', 'Files', 'Service info', 'System setting', and 'Communication'. The top status bar shows a battery icon, 'STOP 94%', and the date '2015/08/30'. The bottom navigation bar is identical to the one in the previous screenshot. To the right of the menu screen, text states: 'You can enter the main menu by pressing **Menu** in the quick buttons bar at the bottom.'

9.4.1 Sensor Settings

Enables you to configure the measurement units and altitude for the S601.

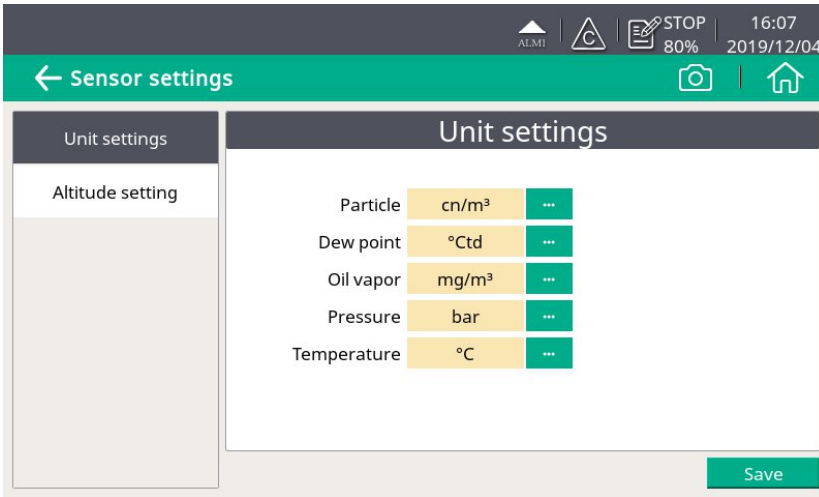

To change the measurement units.

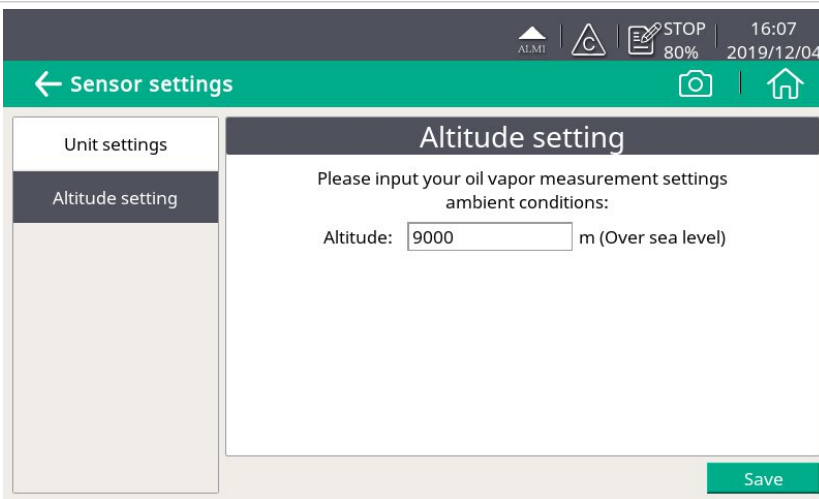

To ensure an accurate oil vapor measurement, enter the altitude where the S601 is placed. The valid values can be positive only.

If the S601 is placed at a negative altitude, please enter 0 instead of the actual negative value.

9.4.2 Alarm Setting

Enables you to define alarms in the S601. The S601 offers two alarm relay outputs and an optical alarm indication (flashing value).

	Channel	Unit	Threshold	Hysteresis	Direction	Relay
0	Location 0 Particle 0.1 < d ≤ 0.5 μm	cn/m ³	5000	0	Up	Relay I
1	Location 0 Dew point Dew point	°Ctd	-11	0	Up	Relay H
2	Location 0 Oil Vapor Oil vapour	ppm	0.1	0	Up	Ext. Rela

Channel	Select a channel to be configured.
Unit	The unit is shown automatically after the channel is selected.
Hysteresis	<p>The alarm is activated when the channel reading reaches the threshold and deactivated when the reading is the threshold minus hysteresis (high alarm) or the threshold plus hysteresis (low alarm).</p> <p>For example: The threshold is 30 and hysteresis is 5. High alarm is activated on channel reading ≥ 30 and deactivated on readings < 25. Low alarm is activated on channel reading ≤ 30 and deactivated on readings > 35.</p>
Direction	<p>UP indicates a high alarm. The alarm is activated when the reading is higher than the threshold.</p> <p>Down indicates a low alarm. The alarm is activated when the reading is lower than the threshold.</p>
Relay	Select a relay. Relay I and Relay H are equipped by default. In addition, the optional relay module offers 8 additional relays (Ext. Relay 0 to Ext. Relay 7). These 8 relays can only be displayed and used when the optional relay module is installed.
Add button	Click Add to add a channel to set alarm parameters.

Delete button

Click **Delete** to delete the selected channel.

After setting the alarms, you can view the activated alarms or dismiss some alarms through **Menu > Alarm > Activated alarm**.



ATTENTION!

Before installing the relay module, turn off the S601. After the relay module is installed, power on the S601 again. Otherwise, the normal use of the relay module may be affected.

9.4.3 Logger Setting

Enables you to start and stop the logger and view logger status.

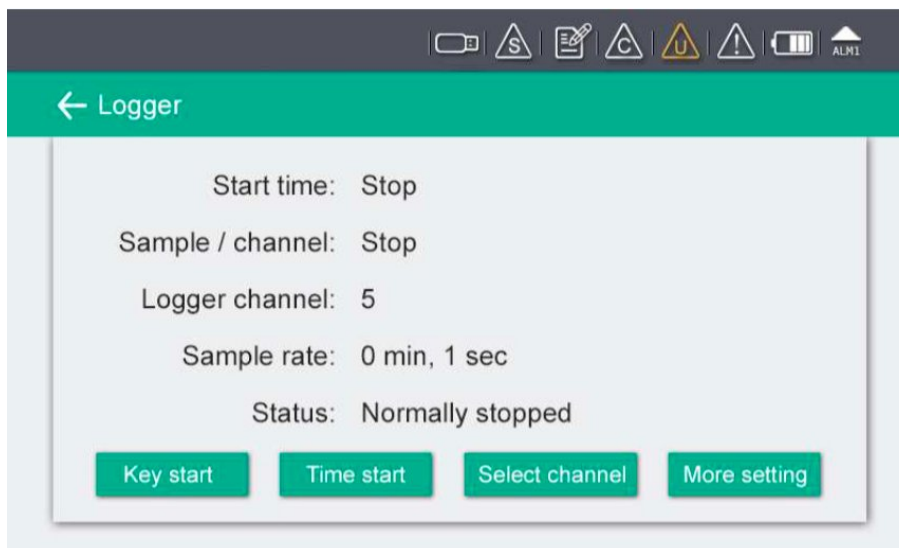

Start time	Shows Logger start time.
Sample / Channel	Show the number of recorded samples per logging channel.
Logger channel	Shows the total number of the recorded channel.
Sample rate	Shows the sampling rate. To change the sampling rate, click More settings .
Status	Shows the logger status.
Key start	Click to start logging immediately.
Time start	Click to configure a scheduled start for logging.
Select channel	Click to select the channel to log for.

More setting

Click to configure the logging interval, logging mode, and memory mode.

- Average: Turning Average on means to log the average value during an interval; turn the average off means the logged value is an instantaneous one.
- Memory mode: Choose a mode as needed.
 - Full stop: Logging stops if the memory is full.
 - Wrap around: If the memory is full, new logging data overwrites the oldest data.

9.4.4 Files

Shows all recorded log files and screenshots as well as memory status. You can select a log file to view log details or to delete the file.

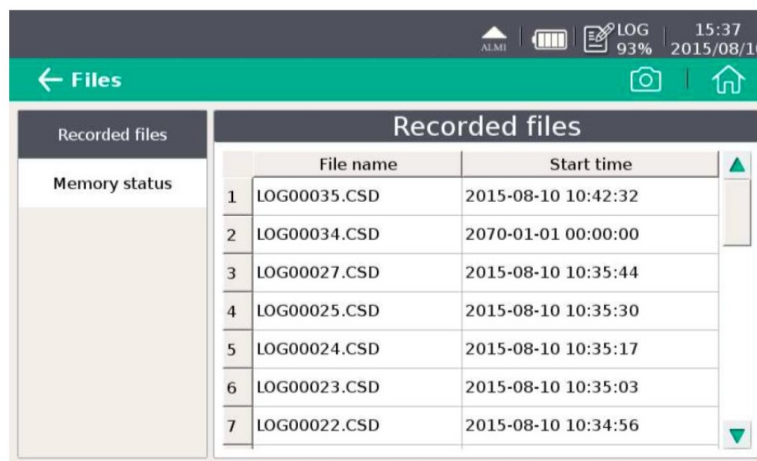

The screenshot shows a mobile application interface with a green header bar labeled 'Files'. Below the header, there are two main sections: 'Recorded files' on the left and a larger 'Recorded files' table on the right. The table has two columns: 'File name' and 'Start time'. The table contains seven rows of log files, each with a number in the first column.

	File name	Start time
1	LOG00035.CSD	2015-08-10 10:42:32
2	LOG00034.CSD	2070-01-01 00:00:00
3	LOG00027.CSD	2015-08-10 10:35:44
4	LOG00025.CSD	2015-08-10 10:35:30
5	LOG00024.CSD	2015-08-10 10:35:17
6	LOG00023.CSD	2015-08-10 10:35:03
7	LOG00022.CSD	2015-08-10 10:34:56

9.4.5 Service Info

Enables you to view the contacts of the service provider, which can be input using the S4C-Display software.

For more information about how to use S4C-Display, see section [9.5 Configuring S601 using S4C-Display](#).

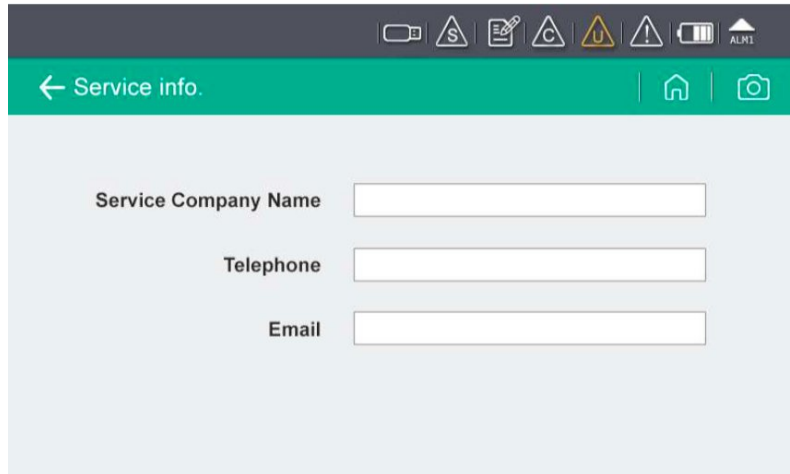

9.4.6 System Setting

Enables you to configure the S601 general settings.

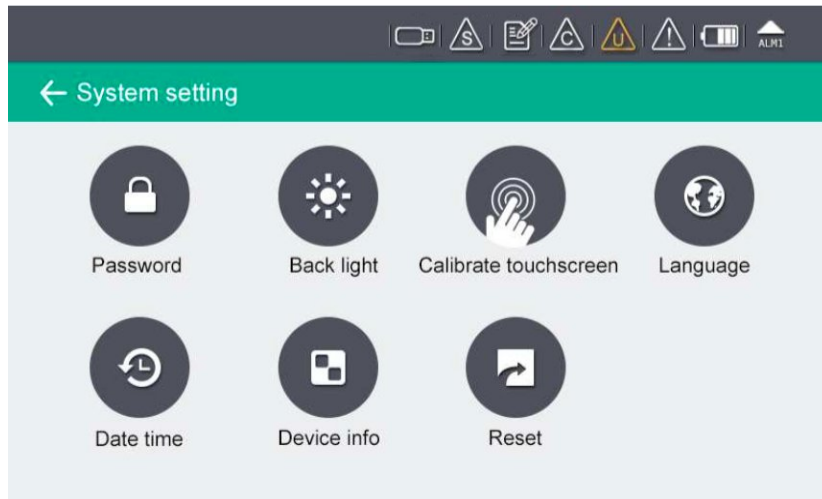

Password	To configure a password to protect the S601 from unauthorized operations.
Back light	To adjust the back light brightness and the dimming timeout.
Calibrate touch screen	To calibrate the touch accuracy.
Language	To select the user interface language.
Date time	To configure the date and time.
Device info	<ul style="list-style-type: none"> To view the device software and hardware information, such as S/N and firmware versions of the system and the sensors. To update the new sensor S/N after an exchange service.

Reset To reboot the display.

9.4.7 Communication

The menu enables to configure the communication settings for S601. Click the desired button and follow the instruction shown on the display.

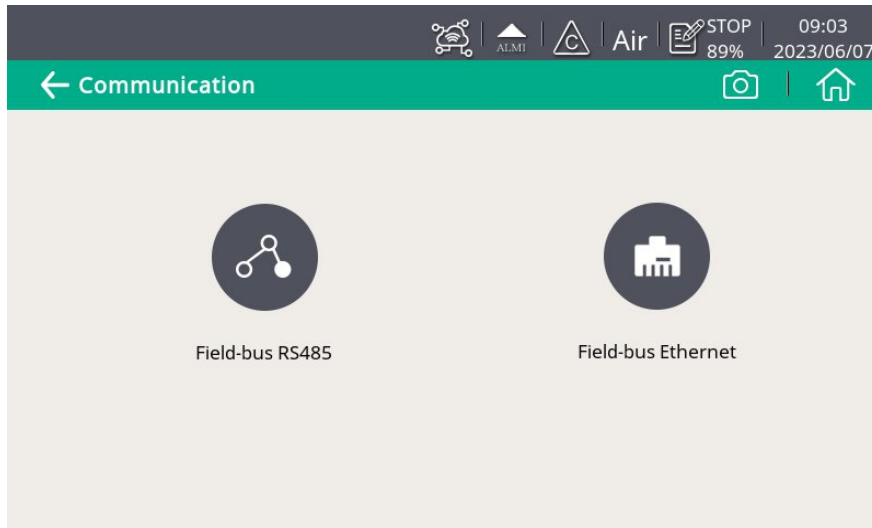

Field-bus RS485 S601 works as the slave. Enter the port (1-247) that S601 uses to communicate with the master.

Field-bus Ethernet Enter an IP address for the S601 or select DHCP for the S601 to be assigned with a dynamic IP address.

9.5 Configuring S601 using S4C-Display

To change the S601 settings, in addition to the S601 display, you can use the configuration software S4C-Display. You can download S4C-Display for free from the SUTO web page at www.suto-itec.com.

The following sections describe how to change the settings using the S4C-Display software, but focus on the Field Bus Interface settings.

9.5.1 RS-485 Settings

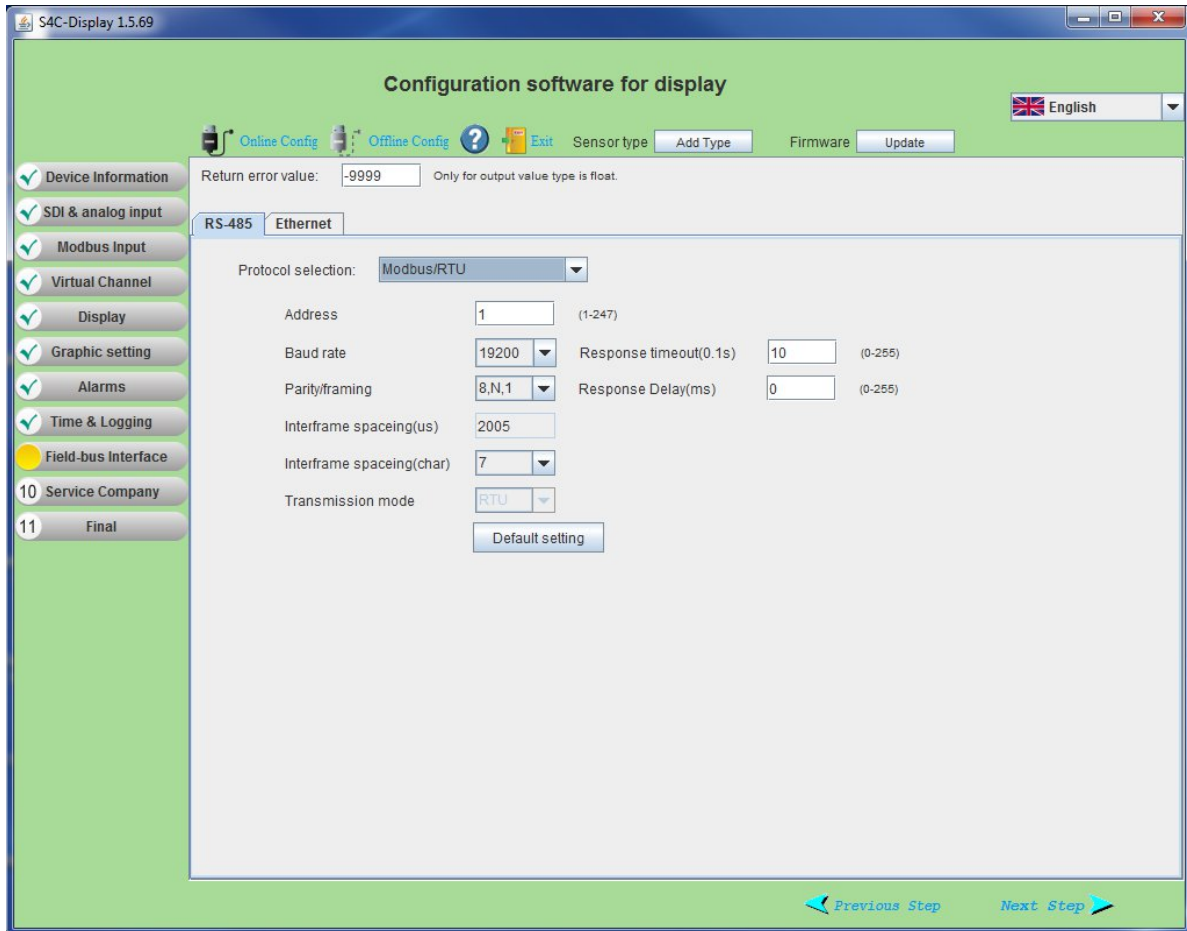

Return error value Is the value the slave device will return as a measurement value in case of any error condition.

- Protocol selection**
- Choose SUTO Protocol if the peer device is using SUTO software.
 - Choose Modbus if the S601 is connected to a Modbus network.

Address Each device on the RS-485 network needs to have a Unique device address. Please ensure that address 0 is not used and that there are no duplicated addresses.

9.5.2 Ethernet Settings

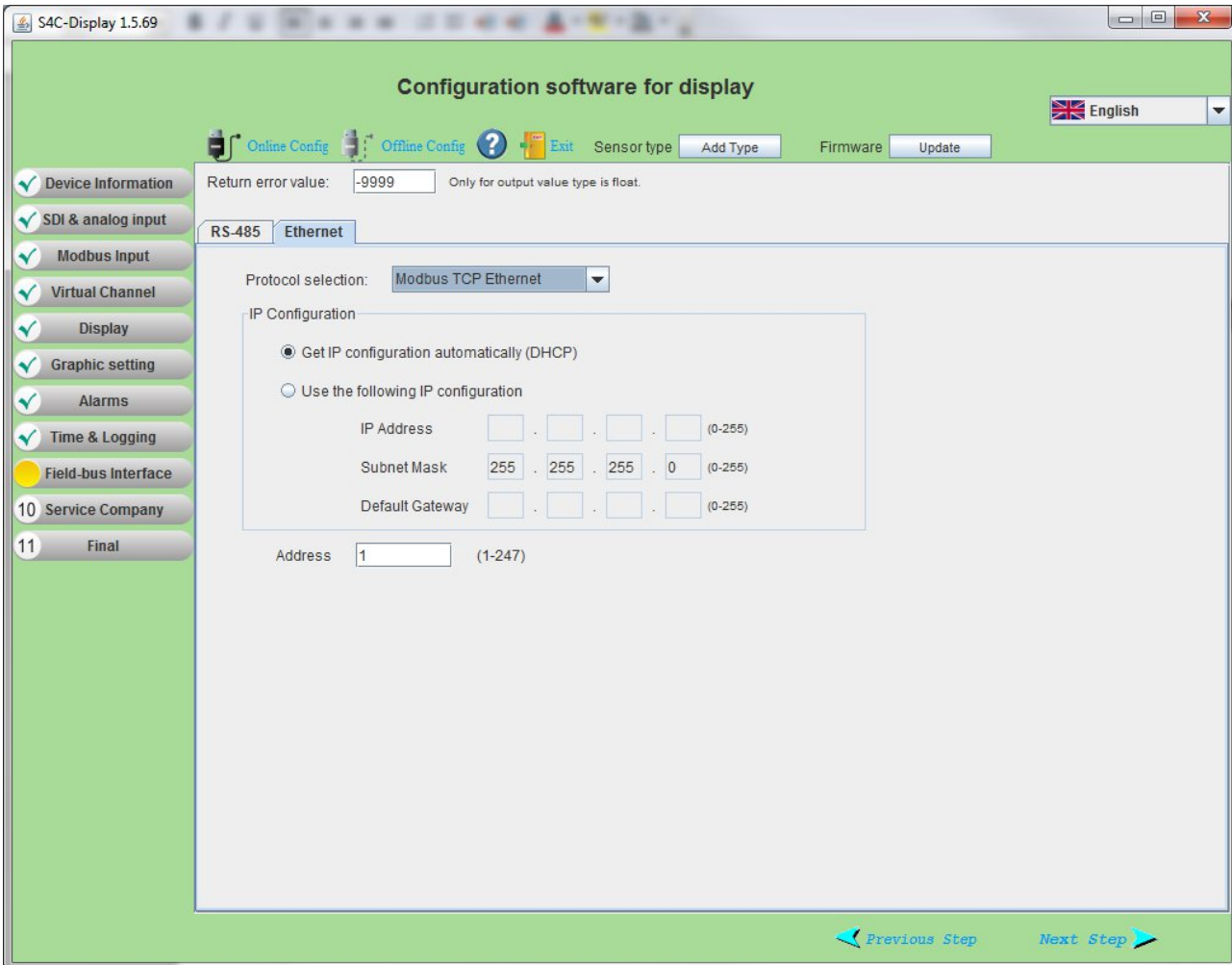

Return error value

Is the value the slave device will return as a measurement value in case of any error condition.

Protocol selection

Please choose SUTO Protocol if using SUTO software, chose Modbus if device is connected to a Modbus network.

Get IP config automatically

After you select this option, the network router will dynamically assign the S601 an IP address. This is convenient but not recommended in industrial networks. It is recommended to assign a static IP address to the S601.

Use the following IP....

Enter the static IP address for the S601.

9.5.3 Modbus Interface

The default settings of the Modbus interface are as follows:

Communication parameters (Modbus/RTU)

- Baud rate : 19200
- Device address : Last two digits of serial number
- Framing / parity / stop bit : 8, N, 1
- Response time : 1 second
- Response delay : 0 ms
- Inter-frame spacing : 7 char

Communication parameters (Modbus/TCP)

- DHCP : Yes
- MAC : Set ex-factory
- IP address : Dynamic or Static
- Subnet : Dynamic or Static
- Gateway : Dynamic or Static
- Timeout : >= 200 ms

Response message that the device returns to the master:

- Function code: 03

The information for the byte order is shown in the table below:

Byte Order	Sequence				Data Type
	1st	2nd	3rd	4th	
1-0-3-2	Byte 1 (MMMMMMMM*)	Byte 0 (MMMMMMMM *)	Byte 3 (SEEEEEEE)	Byte 2 (EMMMMMMM*)	FLOAT
1-0-3-2	Byte 1	Byte 0 LSB	Byte 3 MSB	Byte 2	UINT32 INT32
1-0	Byte 1 MSB	Byte 0 LSB	---	---	UINT16 INT16
1-0	Byte 1 XXX*	Byte 0 DATA	---	---	UINT8 INT8

*S: Sign, E: Exponent, M: Mantissa, XXX: no value

Explanations of MSB and LSB

MSB MSB refers to Most Significant Byte first, which follows the Big-Endian byte order.

For example, if the main system follows the MSB first order:

When the 4-byte floating number, in the order of Byte1-Byte0-Byte3-Byte2, is received from the slave (sensor), the master must change the byte order to Byte3-Byte2-Byte1-Byte0 for the correct display of the value.

LSB LSB refers to Least Significant Byte first, which follows the Little-Endian byte order.

For example, if the main system follows the LSB first order:

When the 4-byte floating number, in the order of Byte1-Byte0-Byte3-Byte2, is received from the slave (sensor), the master must change the byte order to Byte0-Byte1-Byte2-Byte3 for the correct display of the value.

Modbus holding register table

Sensor Description	Channel Description	Holding register	Data type	No. of byte	Unit	Res.	R/W	Func Code
Dew point sensor	Temperature	2	FLOAT_L	4	°C	0.1	R	3
	Dew point	4	FLOAT_L	4	°C Td	0.1	R	3
	Serial number sensor 1	10	UINT32_L	4		1	R	3
	Serial number sensor 2	12	UINT32_L	4		1	R	3
	Device status Dew point	14	UINT32_L	4		1	R	3
Particle counter	0.1 < d ≤ 0.5 um	20	FLOAT_L	4	cn/m ³	1	R	3
	0.5 < d ≤ 1.0 um	22	FLOAT_L	4	cn/m ³	1	R	3
	1.0 < d ≤ 5.0 um	24	FLOAT_L	4	cn/m ³	1	R	3
	0.3 < d ≤ 0.5 um	26	FLOAT_L	4	cn/m ³	1	R	3
	d > 5 um	28	FLOAT_L	4	cn/m ³	1	R	3
	Serial number	30	UINT32_L	4		1	R	3
	Device status particle	32	UINT32_L	4		1	R	3
Oil vapor sensor	Oil vapor	40	FLOAT_L	4	mg/m ³	0.001	R	3
	Pressure	42	FLOAT_L	4	bar	0.01	R	3
	Serial number sensor	48	UINT32_L	4		1	R	3
	Device status oil vapor	50	UINT32_L	4		1	R	3
Display unit	Serial number display	60	UINT32_L	4		1	R	3
	Serial number sensor rack	62	UINT32_L	4		1	R	3
	Device status display	64	UINT32_L	4		1	R	3

Remarks:

- Device status information will be defined in a later state.
- Display unit serial number is the same number as the serial number of the complete S601 unit.

10 Software Installation

Following software is available for download from www.suto-itec.com:

S4C-Display	Free configuration software
S4A	Free logger readout and data analysis software
S4M	Multiple-device data acquisition and analysis software

After download, please follow the onscreen instructions to install the software.

11 Optional Accessories

To buy the following optional accessories, please contact the manufacturer or your local dealer.

- Teflon hoses
- Sorts of adapters
- Relay module (P/N: A1510)

12 Maintenance

Use a moist fabric to clean the device. For the use in GMP-area, it is possible to disinfect through wipe disinfection. For this please contact the manufacturer or your local dealer.



ATTENTION!

Please dry the device after cleaning using a clean and dry fabric. Always take care, that the fabric for cleaning is not too wet because water could get into the device and cause damage.

13 Disposal of Waste



Electronic devices are recyclable material and do not belong in the household waste.

The device, the accessories and its packing must be disposed according to your local statutory requirements. The dispose can also be carried by the manufacturer of the product, for this please contact the manufacturer.

14 Calibration

For calibration we recommend you use our exchange service, where the complete sensor unit is exchanged with a newly-calibrated unit. This saves time and costs.



ATTENTION!

Save all your measurement data on an external device before returning the instrument to calibration and service. It might be necessary to reset the displays storage during calibration and service.

After exchanging a new sensor unit, input its serial number to the S601 through **Menu > System Setting > Device info.**

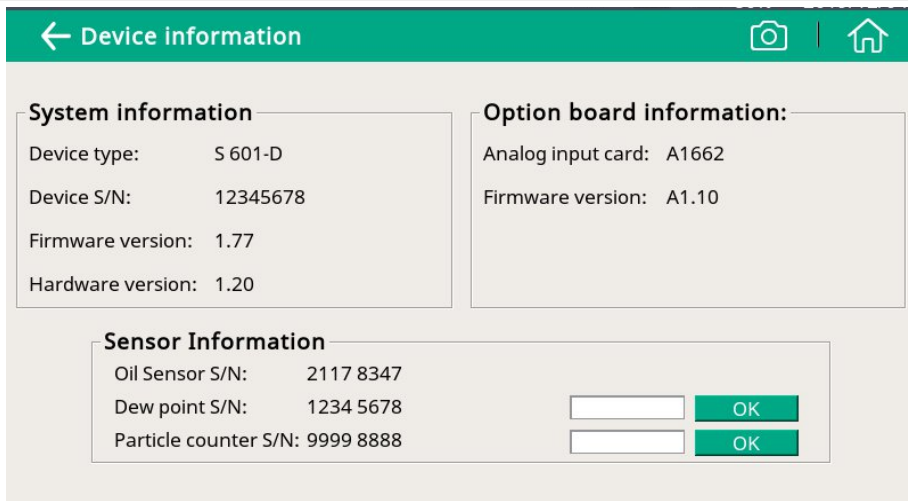

15 Warranty

Please find the warranty as a separated warranty card included with the instrument delivery.

The warranty does not cover any wear parts or consumables, therefore the UV lamp with limited lifetime as well as the internal filter are not covered by the warranty.

SUTO iTEC GmbH

Grißheimer Weg 21
D-79423 Heitersheim
Germany

Tel: +49 (0) 7634 50488 00
Email: sales@suto-itec.com
Website: www.suto-itec.com

SUTO iTEC (ASIA) Co., Ltd.

Room 10, 6/F, Block B, Cambridge Plaza
188 San Wan Road, Sheung Shui, N.T.
Hong Kong

Tel: +852 2328 9782
Email: sales.asia@suto-itec.com
Website: www.suto-itec.com

SUTO iTEC Inc.

5460 33rd St SE
Grand Rapids, MI 49512
USA

Tel: +1 (616) 800 -7886
Email: sales.us@suto-itec.com
Website: www.suto-itec.com

SUTO iTEC (Thailand) Co., Ltd.

Head Office: 91/66 Suwinthawong Rd,
Minburi Bangkok 10510
Thailand

Tel: +66 (0)2108 9658
Email: sales.th@suto-itec.com
Website: www.suto-itec.com