

Instruction and Operation Manual

S418

Compact Thermal Mass Flow Meter (Pro-Inline)



Dear Customer,

Thank you for choosing our product.

Before you start up the device, please read the operating instructions in full and carefully observe them. The manufacturer cannot be held liable for any damage which occurs as a result of non-observance or non-compliance with this manual.

Should the device be tampered with in any manner other than a procedure which is described and specified in the manual, the warranty is canceled and the manufacturer is exempt from liability.

The device is destined exclusively for the described application.

SUTO iTEC offers no guarantee for the suitability for any other purpose. SUTO iTEC is also not liable for consequential damage resulting from the delivery, capability or use of this device.

Revision: 2026-1



Last modifications: January, 2026

Table of Contents

1	Safety Instructions.....	4
2	Registered Trademarks.....	6
3	RF Exposure Information and Statement.....	7
4	Application.....	8
5	Features.....	8
6	Technical Data.....	9
6.1	General Data.....	9
6.2	Electrical Data.....	10
6.3	Data Logger.....	10
6.4	Output Signals.....	10
6.5	Accuracy	11
6.6	Flow Ranges.....	11
6.7	Additional Data for Models with Pressure Sensor.....	12
7	Dimensional Drawing.....	13
7.1	S418 Dimension.....	13
7.2	Thread Adapter Dimension.....	17
8	Installation.....	18
8.1	Installation Considerations.....	19
8.2	Electrical Connection.....	20
8.3	Information on the Display.....	21
8.3.1	Measurement Data on the Display.....	21
8.3.2	LED Indicators.....	21
8.3.3	Error Codes.....	22
9	Signal Outputs.....	23
9.1	Analog Output.....	23
9.2	Pulse Output.....	23
9.3	Modbus Interface.....	24
9.3.1	Modbus Information.....	24
9.3.2	Connect Several S418 to Modbus Master.....	25
9.4	M-Bus Output.....	29
9.5	Connection between S418 Outputs and Customer Equipment. . .	29
10	Configuration.....	31
11	Read and Analysis of Measurement Data.....	32
11.1	Data Logger.....	32
11.2	Operations.....	33
11.2.1	Logger Configuration.....	33
11.2.2	Data Read-out and Analysis.....	33
12	Calibration.....	35
13	Maintenance.....	35
14	Disposal of Waste.....	35

1 Safety Instructions

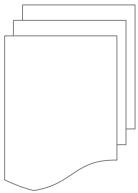

Please check if this instruction manual matches the product type.

Please observe all notes and instructions indicated in this manual. It contains essential information which must be observed before and during installation, operation and maintenance. Therefore this instruction manual must be read carefully by the technician as well as by the responsible user/qualified personnel.

This instruction manual must be available at the operation site of the flow sensor at any time. In case of any obscurities or questions, regarding this manual or the product, please contact the manufacturer.

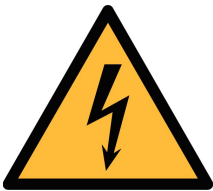

WARNING!

Compressed air!

Any contact with quickly escaping air or bursting parts of the compressed air system can lead to serious injuries or even death!

- Do not exceed the maximum permitted pressure range (see sensors label).
- Only use pressure tight installation material.
- Avoid that persons get hit by escaping air or bursting parts of the instrument.
- The system must be pressureless during maintenance work.

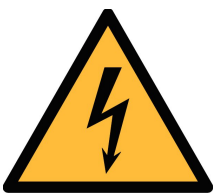

WARNING!

Voltage used for supply!

Any contact with energized parts of the product might lead to an electrical shock, which can lead to serious injuries or even death!

- Consider all regulations for electrical installations.
- The system must be disconnected from any power supply during maintenance.
- Any electrical work on system is only allowed by authorized qualified personal.

**ATTENTION!****Permitted operating parameters!**

Observe the permitted operating parameters, any operation exceeding this parameters can lead to malfunctions and might result in damage on the instrument or the system.

- Do not exceed the permitted operating parameters.
- Make sure the product is operated in its permitted limitations.
- Do not exceed or undercut the permitted storage and operating temperature and pressure.
- The product should be maintained and calibrated frequently, at least annually.

General safety instructions

- It is not allowed to use the product in explosive areas.
- Please observe the national regulations before/during installation and operation.

Remarks

- It is not allowed to disassemble the product.

**ATTENTION!****Measurement values can be affected by malfunction!**

The product must be installed properly and frequently maintained, otherwise it may lead to wrong measurement values, which can lead to wrong results.

- Always observe the direction of the flow when installing the sensor. The direction is indicated on the housing.
- Do not exceed the maximum operating temperature at the sensors tip.
- Avoid condensation on the sensor element as this will affect accuracy enormously.

Storage and transportation

- Make sure that the transportation temperature is between -30 ... +70 °C.
- For storage and transportation it is recommended to use the packaging which comes with the sensor.
- Make sure that storage temperature of the sensor is between -10 ... +50°C.
- Avoid direct UV and solar radiation during storage.
- For the storage the humidity must be <90% with no condensation.

2 Registered Trademarks

Trademark	Trademark owner
SUTO®	SUTO iTEC
MODBUS®	Modbus Organization, Hopkinton, USA
Android™, Google Play	Google LLC

3 RF Exposure Information and Statement

This equipment complies with FCC RF radiation exposure limits set forth for an uncontrolled environment. This equipment should be installed and operated with minimum distance of 20 cm between the radiator and your body.

This device complies with part 15 of the FCC rules. Operation is subject to the following two conditions: (1) this device may not cause harmful interference, and (2) this device must accept any interference received, including interference that may cause undesired operation.

NOTE: The manufacturer is not responsible for any radio or TV interference caused by unauthorized modifications to this equipment. Such modifications could void the user's authority to operate the equipment.

NOTE: This equipment has been tested and found to comply with the limits for a Class B digital device, pursuant to part 15 of the FCC Rules. These limits are designed to provide reasonable protection against harmful interference in a residential installation. This equipment generates uses and can radiate radio frequency energy and, if not installed and used in accordance with the instructions, may cause harmful interference to radio communications. However, there is no guarantee that interference will not occur in a particular installation. If this equipment does cause harmful interference to radio or television reception, which can be determined by turning the equipment off and on, the user is encouraged to try to correct the interference by one or more of the following measures:

- Reorient or relocate the receiving antenna.
- Increase the separation between the equipment and receiver.
- Connect the equipment into an outlet on a circuit different from that to which the receiver is connected.
- Consult the dealer or an experienced radio/TV technician for help.
- This device and its antenna(s) must not be co-located or operating in conjunction with any other antenna or transmitter.

4 Application

The S418 is a Compact Thermal Mass Flow Meter designed to measure the consumption of compressed air and other gases within the permissible operating parameters. These parameters are stated in chapter [6 Technical Data](#).

The S418 can measure the following parameters:

- Volumetric flow (default unit: l/min)
- Total consumption (default unit: m³)
- Pressure of the fluid (optional) (default unit: bar)

Other units are configurable using the service App S4C-FS, which can be downloaded from the Google Play Store or SUTO Website. For more information see chapter [10](#).

5 Features

- Inline thermal mass flow meter virtually independent of pressure and temperature changes.
- Process connection of G-type thread with DN8, DN15, DN20, DN25, DN32, DN40, and DN50 available
- Very short response time.
- Particularly suitable for measuring at the point-of-use flow and consumption of compressed air and other gases.
- Integrated display showing volumetric flow.
- Options for output signals:
 - Analogue 4 ... 20 mA and pulse output
 - Modbus interface
 - M-Bus interface
- Wireless interface for remote sensor settings
- Configurable through Android or iOS devices
- Embedded Data logger capable of recording 5-million measurement samples

6 Technical Data

6.1 General Data

 FCC ID: 2ASK2-SUTO-003	
Parameters	Volumetric flow: l/min, m ³ /h, m ³ /min, cfm Consumption: m ³ , ft ³ Medium pressure: bar, psi
Reference conditions	Selectable by users. Default ex-factory settings: <ul style="list-style-type: none"> • Compressed air: ISO1217 20°C, 1000 hPa • Other gas: DIN1343 0°C, 1013.25 hPa
Principle of measurement	Thermal mass flow
Sensor	Glass coated resistive sensor
Measured gases	Non-corrosive gases, up to 2 calibrated gases
Ambient temperature /Transport temperature	0 ... +50°C / -30 ... +70°C
Medium conditions	0 ... +50°C, rH<90%, no condensation
Operating pressure	0 ... 1.6 MPa
Pressure drop	Maximum pressure drop at the maximum flow of Standard (S) flow range: <ul style="list-style-type: none"> • DN8 type : 30 hPa • DN15 type: 100 hPa • DN20 type: 100 hPa • DN25 type: 200 hPa • DN32 type: 170 hPa • DN40 type: 160 hPa • DN50 type: 180 hPa
Casing	Process connection: <ul style="list-style-type: none"> • Aluminum alloy for all pipe types • Stainless steel SUS316L/1.4404 for DN8, DN15, DN20, and DN25 Contact part: aluminum alloy or stainless steel SUS316L/1.4404 Top casing: PC + ABS
Protection class	IP54
Dimensions	See dimensional drawing on page 13 .

Display	4-digit LED display
Tube diameter	DN8, DN15, DN20, DN25, DN32, DN40, DN50
Process connection:	G inner thread ISO 228-1 Thread adapter, NPT1/2" inner thread to G1/2" outer thread
Weight	<ul style="list-style-type: none"> • Aluminum alloy type 0.43 kg (DN8), 0.46 kg (DN15), 0.96 kg (DN20), 0.97 kg (DN25), 1.7 kg (DN32), 2.7 kg (DN40), 4.3 kg (DN50) • Stainless steel type: 1 kg (DN8), 0.97 kg (DN15), 2.45 kg (DN20), 2.36 kg (DN25)

6.2 Electrical Data

Power supply	15 ... 30 VDC, 120 mA @ 24 VDC
--------------	--------------------------------

6.3 Data Logger

Memory size	Up to 8,000,000 samples.
Recording channels	Up to 3: flow, consumption, and pressure.
Logger programming	Use the mobileApp S4C-FS (Free for download on Google Play Store)
Logger readout	Use Windows-based software - S4A via USB (Free for download on the SUTO Website)

Remark: The total consumption value is saved to the permanent memory every 5 minutes. If within these 5 minutes the device is powered off, it will restore the last consumption value which was saved in the last cycle.

6.4 Output Signals

Analogue output	Signal: 4 ... 20 mA, isolated Scaling: 0 to max flow Max load: 250R
Pulse output	1 pulse per consumption unit (m ³ or ft ³) isolated switch, max. 30 VDC, 200 mA (pulse length: 10 ... 120 ms, depends on flow rate)
Modbus output	See section 9.3 on page 24

6.5 Accuracy

Accuracy*	$\pm(1.5\% \text{ of reading} + 0.3\% \text{ F.S.})$
Temperature coefficient	$< 0.1\%/K \text{ FS}$
Pressure coefficient	2% / 1 MPa
Turndown ratio	100:1
Stated accuracy at	Ambient/process temperature $23^{\circ}\text{C}\pm 3^{\circ}\text{C}$ Ambient/process humidity $< 90\%$ Process pressure at 0.6 MPa
Repeatability	$\pm 0.5\%$ of reading
Sampling rate	10 samples per second

* The specified accuracy is valid only within the minimum and maximum flow rates that are indicated in section 6.6.

6.6 Flow Ranges

Unit: l/min; Media: Standard flow in air; Reference pressure: 1000 hPa;
Reference Temperature: $+20^{\circ}\text{C}$

	DN8		DN15		DN20		DN25		DN32		DN40		DN50	
	Min	Max	Min	Max	Min	Max	Min	Max	Min	Max	Min	Max	Min	Max
Standard range (S)	2.5	250	10	1000	20	2000	35	3500	60	6000	200	10000	280	14000
Low range (L)	0.5	50	2	200	4	400	7	700	12	1200	40	2000	56	2800

Unit: l/min; Condition: N_2 at 0°C and 1013.25 hPa

	DN8		DN15		DN20		DN25		DN32		DN40		DN50	
	Min	Max	Min	Max	Min	Max	Min	Max	Min	Max	Min	Max	Min	Max
Standard range (S)	2.22	222	8.9	890	17.8	1780	31.1	3110	53	5335	178	8879	246	12304
Low range (L)	0.45	44.5	1.78	178	3.56	356	6.22	622	11	1067	36	1776	49	2461

Unit: l/min; Condition: **O₂** (Oil-and grease-free) at 0°C and 1013.25 hPa

	DN8		DN15		DN20		DN25		DN32		DN40		DN50	
	Min	Max	Min	Max	Min	Max	Min	Max	Min	Max	Min	Max	Min	Max
Standard range (S)	2.38	238	9.53	953	19.07	1907	33.37	3337	57	5720	95	9520	132	13192
Low range (L)	0.45	47.7	1.91	191	3.81	381	6.67	667	11	1144	19	1904	26	2638

Note: To calculate flow ranges based on pipe sizes and reference conditions in your site, SUTO offers the "Flow Range Calculator" tool for free. The tool can be used online from <http://www.suto-itec.com> by clicking **Support > Flow Range Calculator**.

SENSOR SELECTION

Sensor Type
S418 ▼

Measuring section
DN8 ▼

Measuring range
Standard ▼

Pipe inner diameter
15.0

Profile
0.660

Cut-off velocity
▼

CALCULATOR OUTPUTS

Max. flow **15.0** **Sm³/h**

Min. flow **0.2** **Sm³/h**

Max. velocity 35.7 Sm/s

Min. velocity 0.0 m/s

6.7 Additional Data for Models with Pressure Sensor

Accuracy	±0.5% FS
Parameters	Pressure: bar (default) or psi
Sensor	Piezzo-resistive sensor
Measuring range	0 ... 1.6 MPa

7 Dimensional Drawing

Unit: mm

7.1 S418 Dimension

DN8/DN15

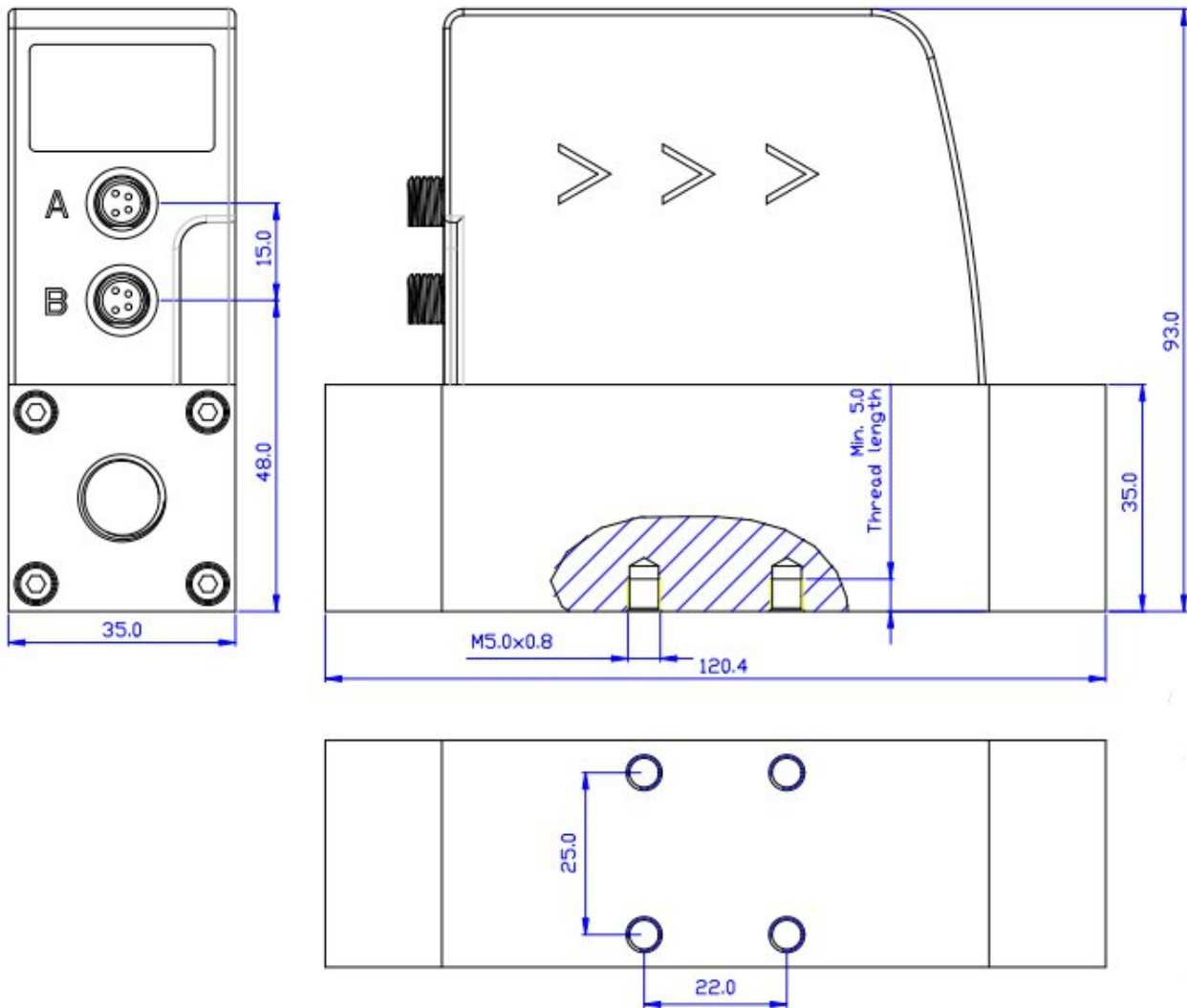

DN20/DN25

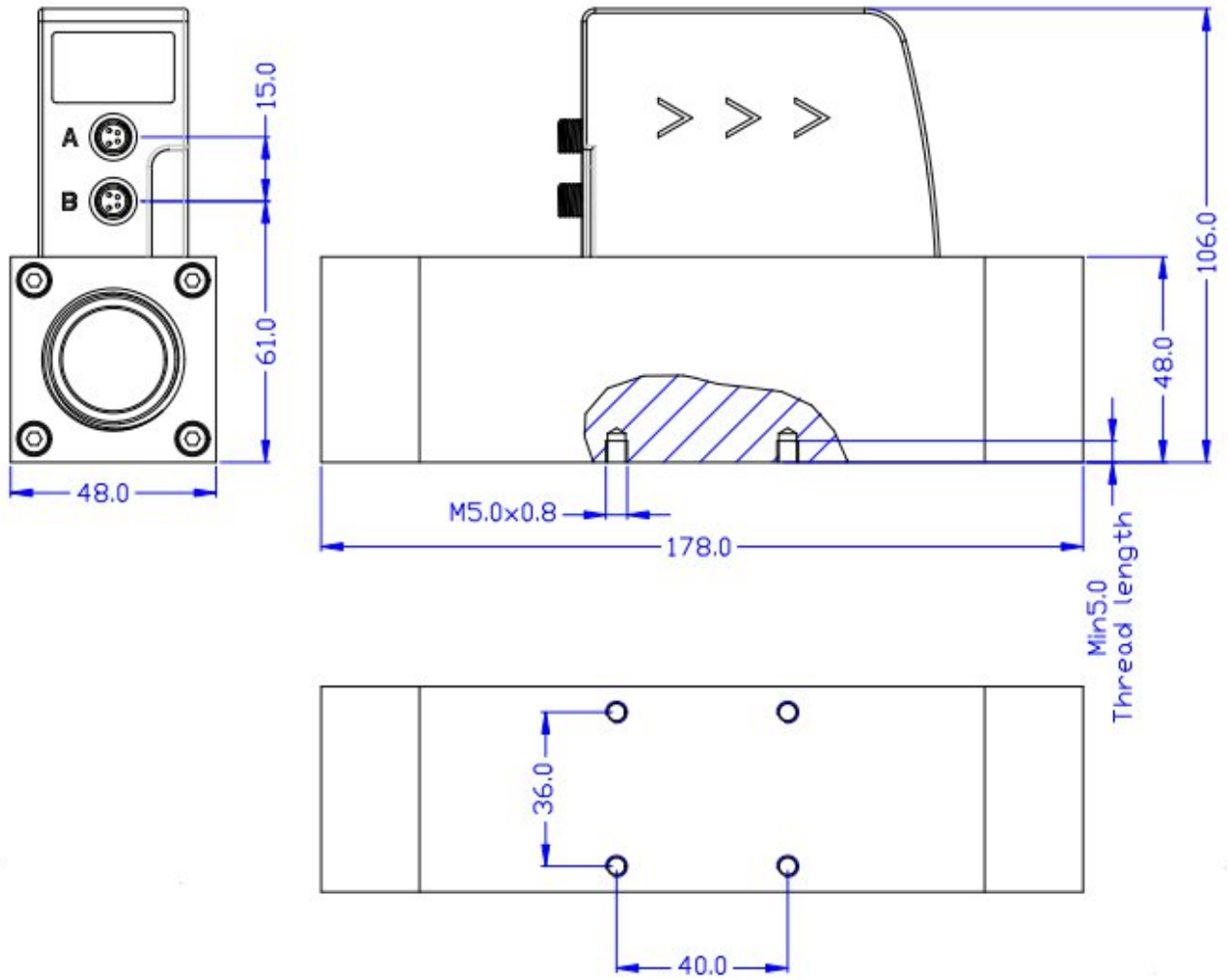

DN32

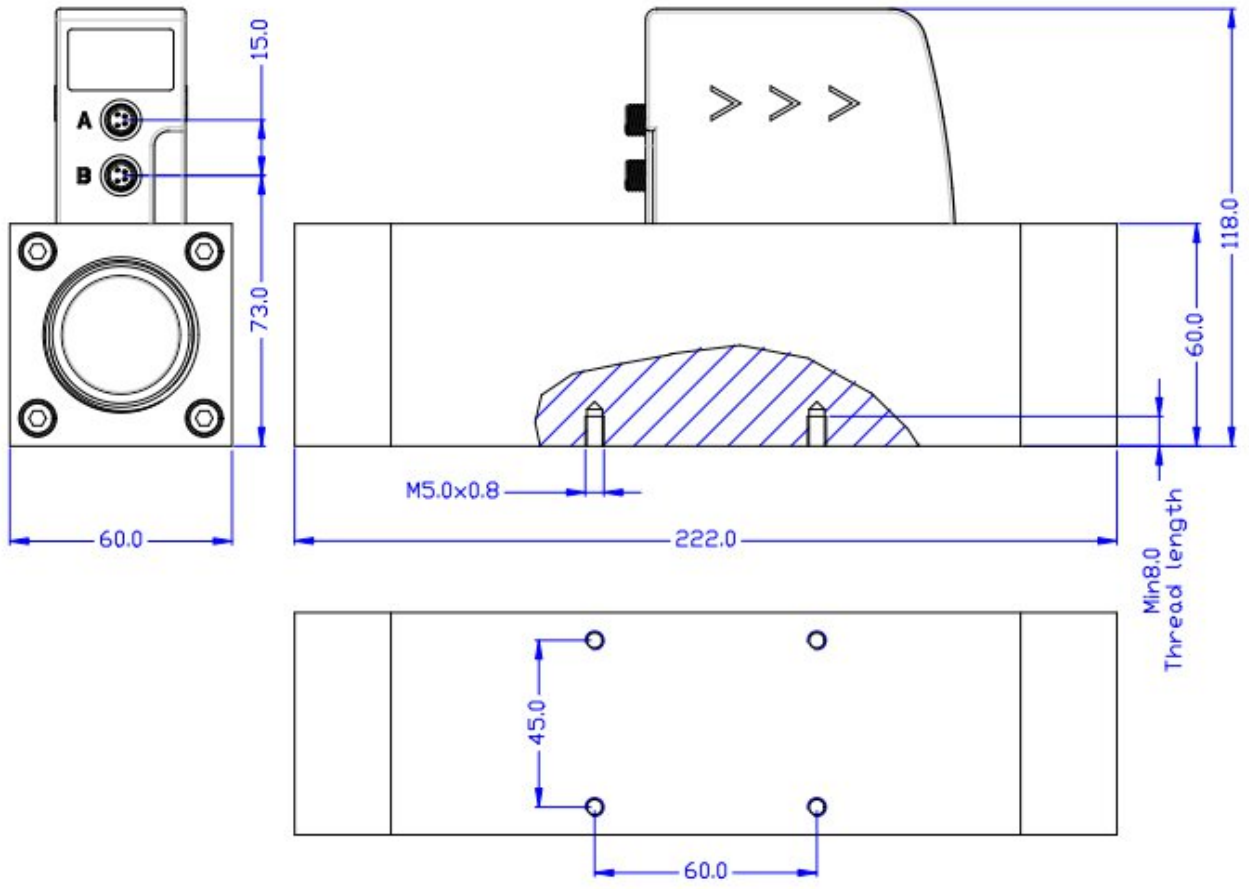

DN40

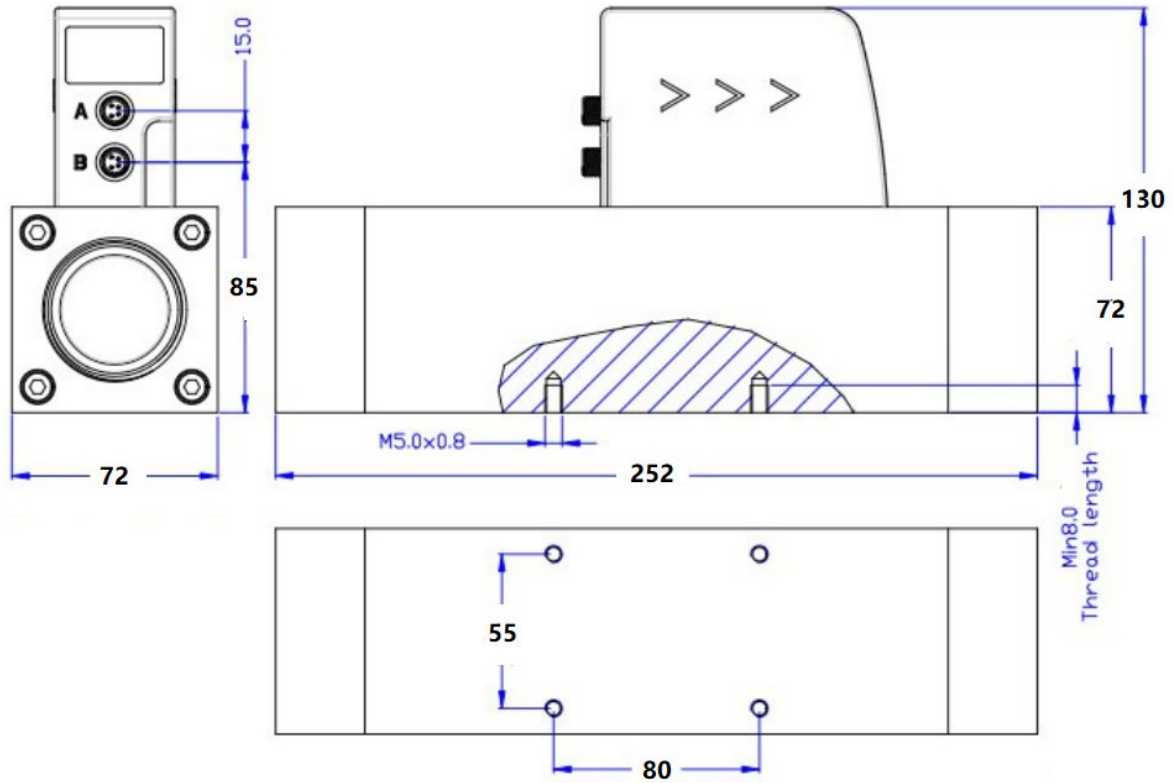

DN50

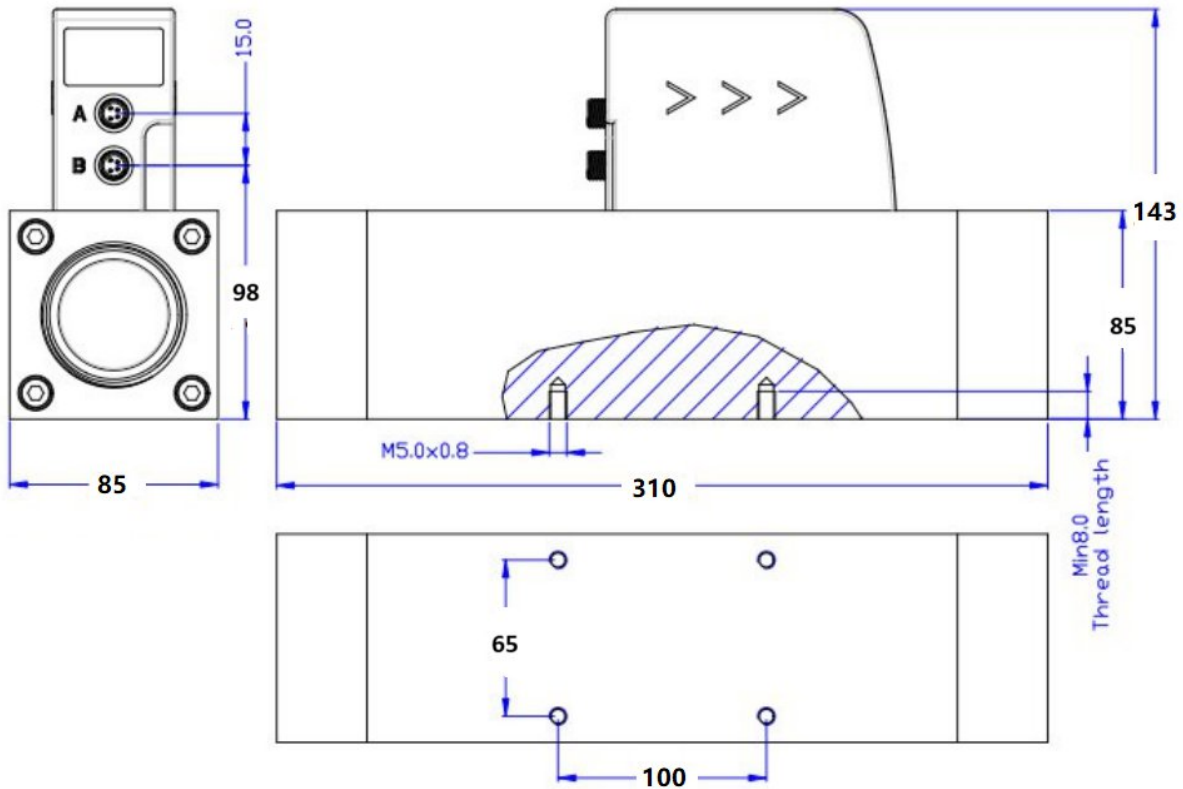

7.2 Thread Adapter Dimension

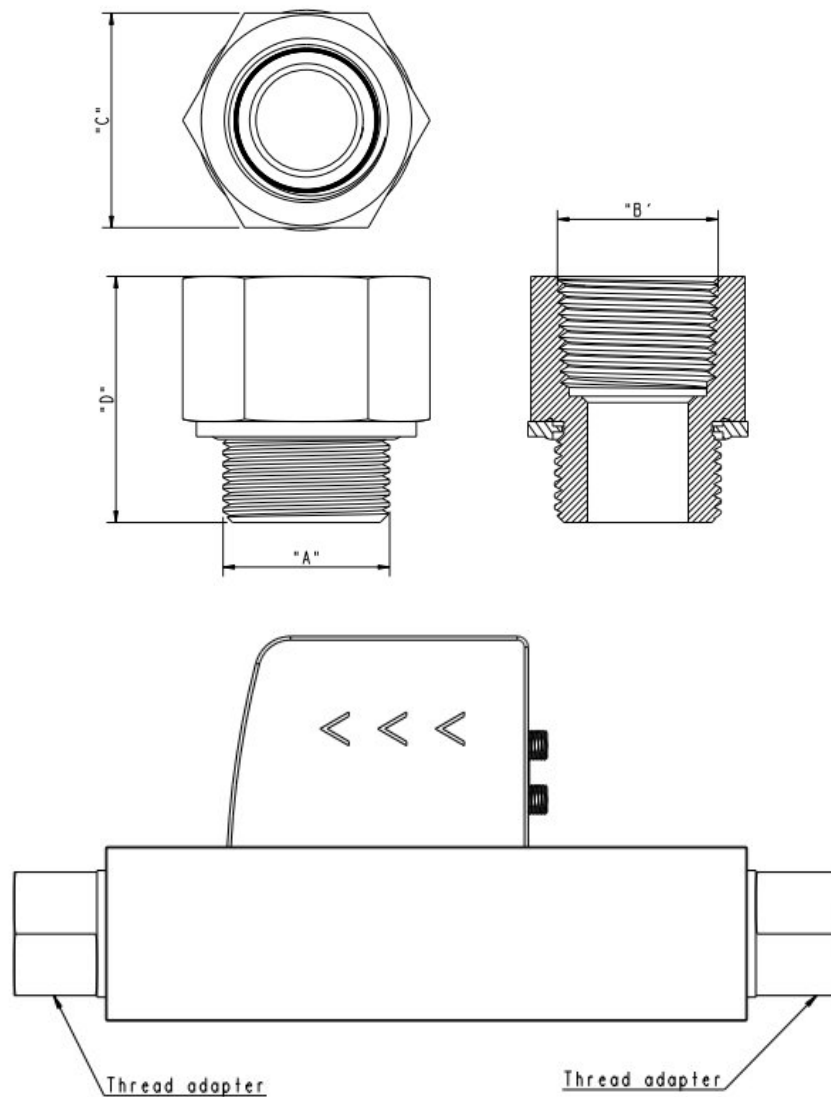

"A" (Outer thread)	"B" (Inner thread)	"C"	"D"	Item No.
G1/4"	NPT1/4"	20.0	29.5	C190 0605A
G1/2	NPT1/2"	26.0	35.5	C190 0605B
G3/4"	NPT3/4"	34.0	39	C190 0605C
G1"	NPT1"	40.0	44	C190 0605D
G1-1/4"	NPT1-1/4"	52.0	48	C190 0605E
G1-1/2"	NPT1-1/2"	60.0	49	C190 0605F
G2"	NPT2"	72.0	52	C190 0605G

8 Installation

S418 is delivered with following components:

Qty.	Description	Order no.	
1	S418 Compact Thermal Mass Flow Meter	Aluminum alloy: Aluminum alloy+ pressure:	
		S695 4180	S695 4185
		S695 4181	S695 4186
		S695 4182	S695 4187
		S695 4183	S695 4188
		S695 4184	S695 4189
		S695 4197	S695 4199
		S695 4198	S695 4200
		Stainless steel: Stainless steel + pressure:	
		S695 0418	S695 4418
		S695 1418	S695 5418
		S695 2418	S695 6418
		S695 3418	S695 7418
		1	5 m cable with M8 connector and open ends
1	USB cable	A553 0130	
1	Instruction and operation manual	No	
1	Calibration certificate	No	

8.1 Installation Considerations

- When installing the flow meter, always observe the arrows on the housing showing the flow direction. The air/gas flow direction must always be in line with the arrows on the housing.



- Due to the integrated flow conditioner, there are no additional straight pipe requirements for good measurement. However for best measurement, it is recommended 3-5 times inner diameter straight pipe at the inlet.
- The S418 can be installed in horizontal or vertical pipes.

Note:

- The device is for indoor use only! For outdoor applications, ensure a protection from solar radiation and rain. Always observe operating temperature and humidity as stated in the technical data.
- It is strongly recommended not to install S418 permanently in wet air/gas conditions, which exists usually right after a compressor outlet.

8.2 Electrical Connection

The flow meter comes with two connector plugs "A" and "B". By default the flow meter is delivered with one 5 m cable with a M8 connector on one side and open wires on the other side. To operate the S418, one cable connection is sufficient. However if the pulse output is to be used or the supply and signal should be on separate cables, a second connection cable must be ordered.

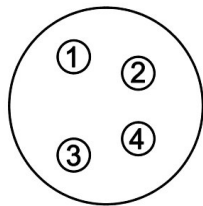
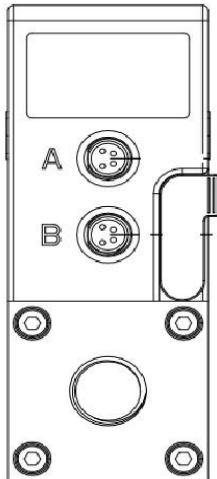

Legend to pin assignment

- GND_M Ground for Modbus
- V_B Negative supply voltage
- +V_B Positive supply voltage
- +I Positive 4 ...20 mA signal (isolated)
- I Negative 4 ... 20 mA signal (isolated)
- D+ Modbus data +
- D- Modbus data -
- SW Isolated pulse output (switch)
- M-Bus M-Bus data
- NA Not Applicable

Pin assignment connector plug M8

Output	Connector	Pin 1	Pin 2	Pin 3	Pin 4
Modbus	A	D-	-V _B	+V _B	D+
	B	D-	GND _M	NA	D+
Pulse and analog	A	-I	-V _B	+V _B	+I
	B	-I	SW	SW	+I
M-Bus	A	M-Bus	-V _B	+V _B	M-Bus
	B	M-Bus	NA	NA	M-Bus
Wire color		Brown	White	Blue	Black



ATTENTION!

Do not screw the M8 plug forcibly. Otherwise, it may damage the connecting pins.

8.3 Information on the Display

8.3.1 Measurement Data on the Display

The screen on the S418 can display the following measurement data:

- Volumetric flow (default unit: l/min)
- Total consumption (default unit: m³)
- Pressure of the fluid (optional) (default unit: bar)
- Temperature (configurable) (default unit: °C)

8.3.2 LED Indicators

The S418 provides four LED indicators on the display panel, which indicate the status of the data logger, display, and wireless connection separately.

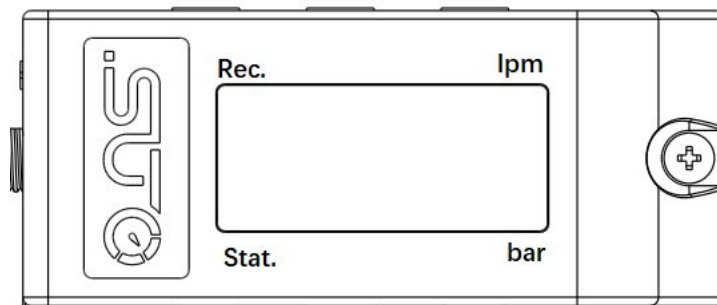

LED	Function	Status
Rec	Indicator for the logger state	On: NAND flash is formatting. Flashing: Data logger is working
lpm	Indicator for the display state (volumetric flow)	On: The display is showing the volumetric flow rate. Flashing: N/A
stat.	Indicator for the wireless connection state	On: The wireless is connected. Flashing: N/A
bar	Indicator for the display state (pressure)	On: The display is showing the pressure value. Flashing: N/A

8.3.3 Error Codes

When an error code shows on the LED display, use the following table to identify the error cause.

Code	Description	Code	Description
Er. 01	Real time clock failure	Er. 20	Flow sensor failure
Er. 02	ADC failure	Er. 30	Temperature sensor failure
Er. 04	EEPROM failure	Er. 40	Wireless connection failure
Er. 08	NAND flash failure	Er. 50	Logger failure
Er. 10	Pressure sensor failure		

9 Signal Outputs

9.1 Analog Output

The device has an analog output of 4 ... 20 mA. This output can be scaled to match a desired measuring range. Standard scaling is from 0 to the max flow. The corresponding flow in different pipe sizes can be found in section [6.6 Flow Ranges](#).

9.2 Pulse Output

The device outputs one pulse per a consumption unit. This pulse output can be connected to an external pulse counter to count the total consumption. The number of m³ per second are summed up and indicated after one second. Pulse length depends on flow rate.

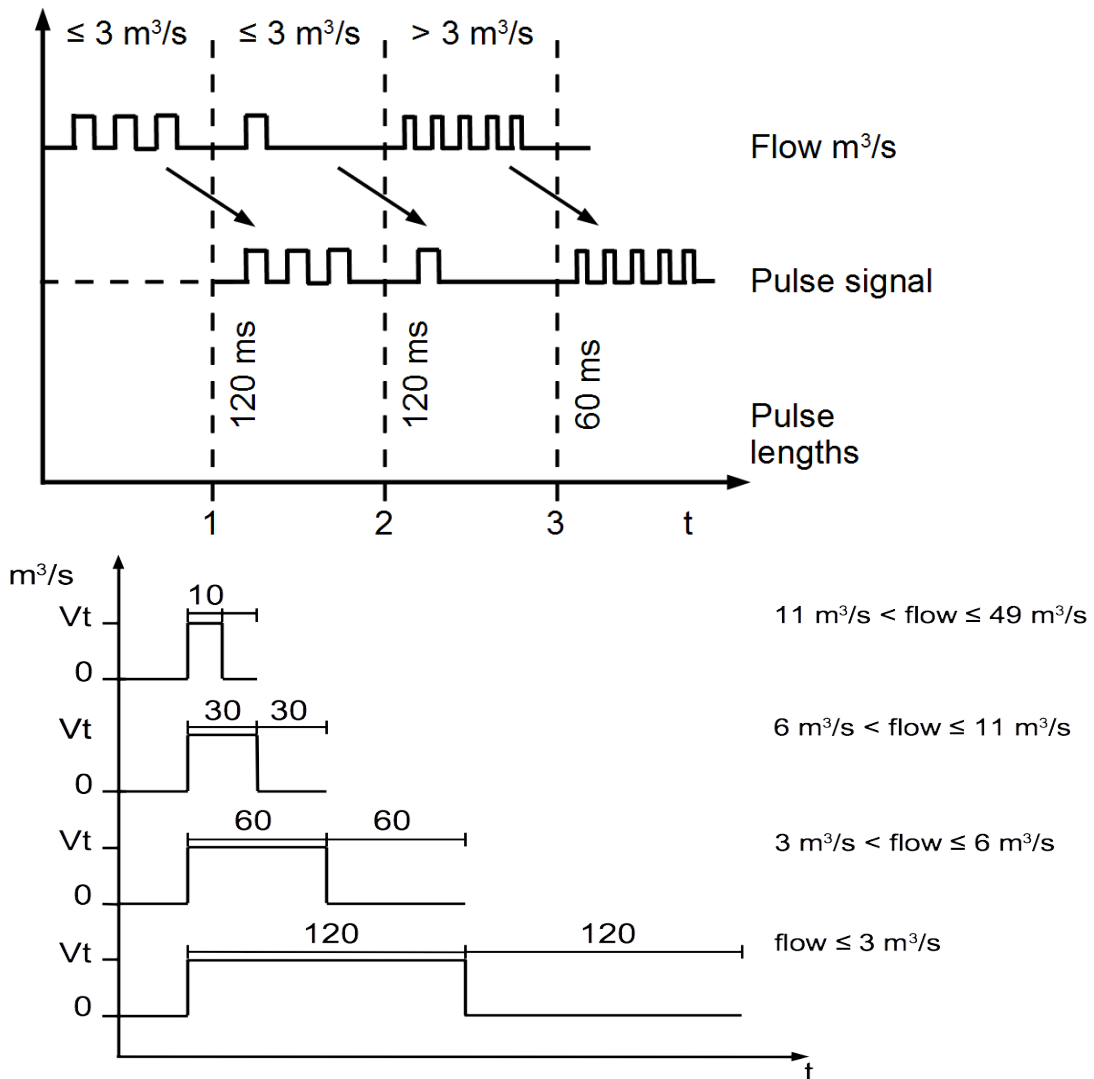

Volumetric flow [m ³ /s]	Volumetric flow [m ³ /h]	Pulse length [ms]	Max. pulse output per hour
≤ 3	≤ 10800	120	1080
> 3	> 10800	60	2880
> 6	> 21600	30	3960

9.3 Modbus Interface

9.3.1 Modbus Information

The default settings of the Modbus interface are as follows:

Mode	RTU
Baud rate	19200
Device address	Last two digits of the serial number
Framing / parity / stop bit	8, N, 1
Response timeout	1 second
Response delay	0 ms
Inter-frame spacing	7 char

Response message that the device returns to the master:

- Function code: 03

The information of the byte order is shown in the table below:

Byte Order	Sequence				Data Type
	1st	2nd	3rd	4th	
1-0-3-2	Byte 1 (MMMMMMMM*)	Byte 0 (MMMMMMMM *)	Byte 3 (SEEEEEEE)	Byte 2 (EMMMMMMM *)	FLOAT
1-0-3-2	Byte 1	Byte 0 LSB	Byte 3 MSB	Byte 2	UINT32 INT32
1-0	Byte 1 MSB	Byte 0 LSB	---	---	UINT16 INT16
1-0	Byte 1 XXX *	Byte 0 DATA	---	---	UINT8 INT8

* S: Sign, E: Exponent, M: Mantissa, XXX: no value

Explanations of MSB and LSB

-
- MSB** MSB refers to Most Significant Byte first, which follows the Big-Endian byte order.
For example, if the main system follows the MSB first order:
When the 4-byte floating number, in the order of Byte1-Byte0-Byte3-Byte2, is received from the slave (sensor), the master must change the byte order to Byte3-Byte2-Byte1-Byte0 for the correct display of the value.
-
- LSB** LSB refers to Least Significant Byte first, which follows the Little-Endian byte order.
For example, if the main system follows the LSB first order:
When the 4-byte floating number, in the order of Byte1-Byte0-Byte3-Byte2, is received from the slave (sensor), the master must change the byte order to Byte0-Byte1-Byte2-Byte3 for the correct display of the value.
-

Note: Modbus communication settings as well as other settings can be changed by the service App **S4C-FS** or through the windows based **Service Software**.

Available measurement channels

Channel description	Resolution	Format	Length	Register address
Flow	0.1	FLOAT	4-byte	6
Consumption	1	UINT32	4-byte	8
Pressure	0.01	FLOAT	4-byte	2

9.3.2 Connect Several S418 to Modbus Master

The S418 with Modbus/RTU interface can be easily daisy-chained to a Modbus Master device. This master can be either SUTO displays and gateways or any third-party Modbus/RTU master.

Through this method you can add up to 16 flow meters to the master device.

9.3.2.1 Modbus/RTU Cable Length

A Modbus/RTU bus line has limitations which shall not be exceeded, otherwise the communication might not be stable.

- The maximum total bus length must not exceed 1200 m.
- The stub length to each node must not exceed 30 cm.

See the picture below for details.

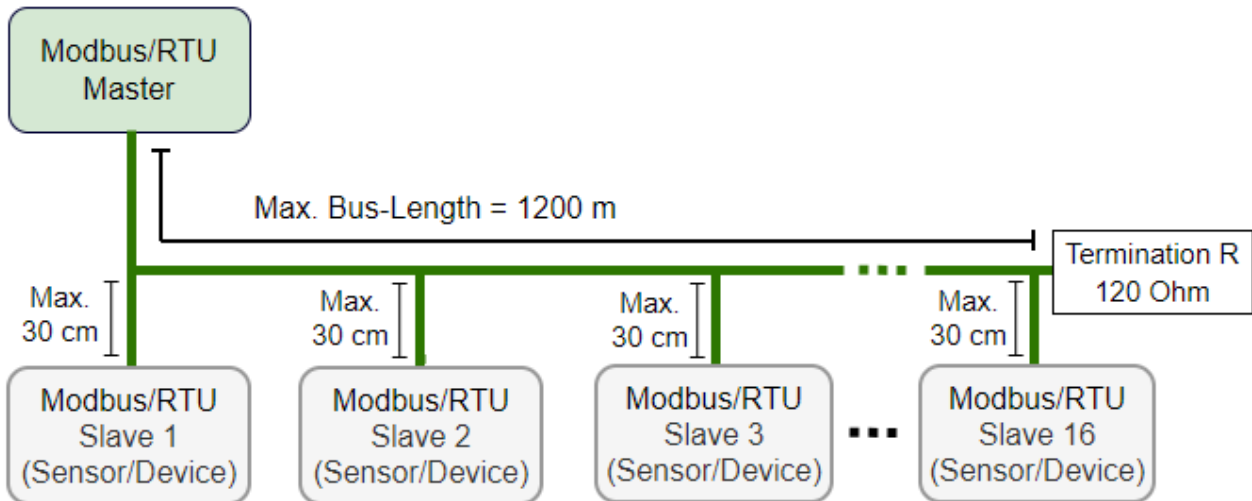

9.3.2.2 Modbus/RTU Wiring and Cable Type

To ensure a stable communication a twisted-pair bus cable must be chosen to set up the Modbus/RTU communication.

- Bus-cable specifications must follow the EIA485 Standard, must be twisted pair and shielded, for example 2 x 2 x 0.22 mm², Li-2YCY (A553 0123).
- The shield must be connected at one end to the master GND connection.
- At the end of the bus, a 120 Ohm resistor should be placed a termination resistor.

See the below picture for details.

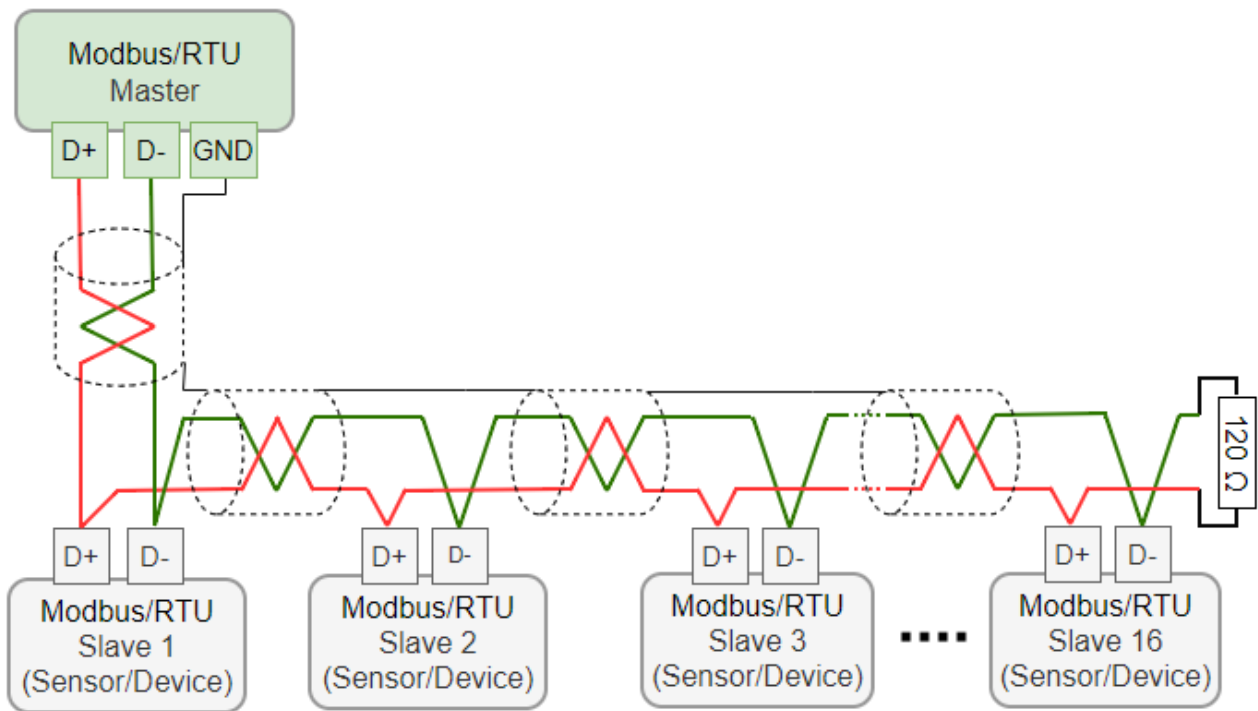

9.3.2.3 Create Daisy-Chain using RS-485 Splitter

To connect the S418 to the daisy-chain, the RS-485 splitter (A554 3310) and the M8 to M12 converter cable (A553 0161) are needed.

Furthermore place a M12 termination resistor (C219 0055) at the last splitter in the daisy-chain, as show in the figure below.

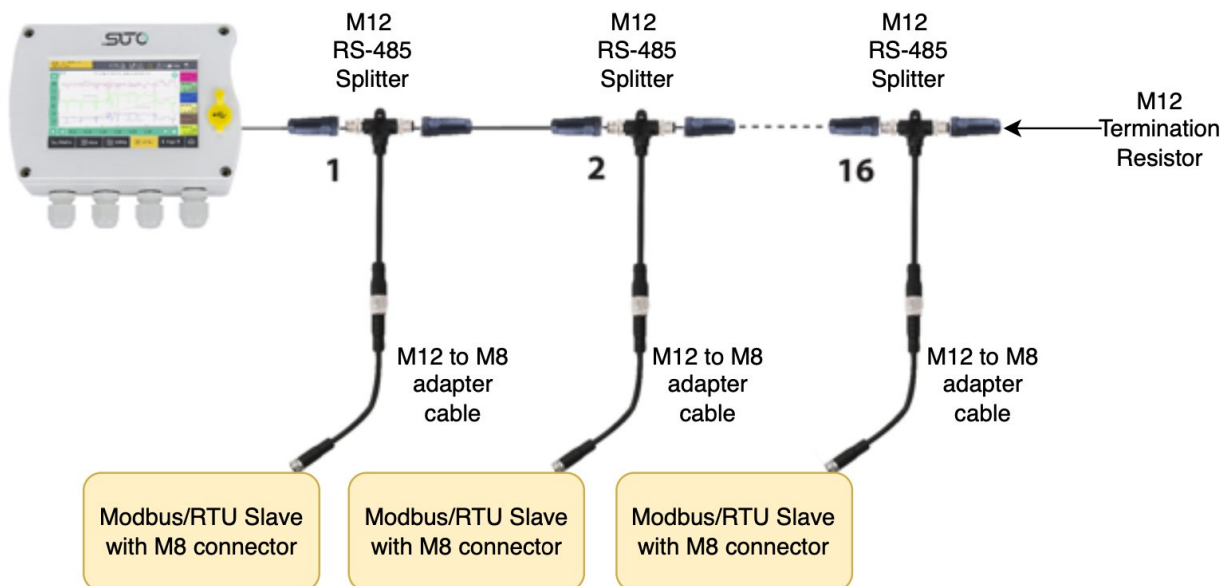

Remark: The S331 can maximum provide 10 W power to the connected devices. If more power is required a separate power supply is needed.

9.3.2.4 Topology of Modbus/RTU Daisy-Chain

The recommended bus topology is to connect devices as a daisy-chain, as shown in the figure in section 9.3.2.1 Modbus/RTU Cable Length. Other connection topologies are not recommended and must be avoided.

Avoid a connection of Slaves to the master in ring or star topology.

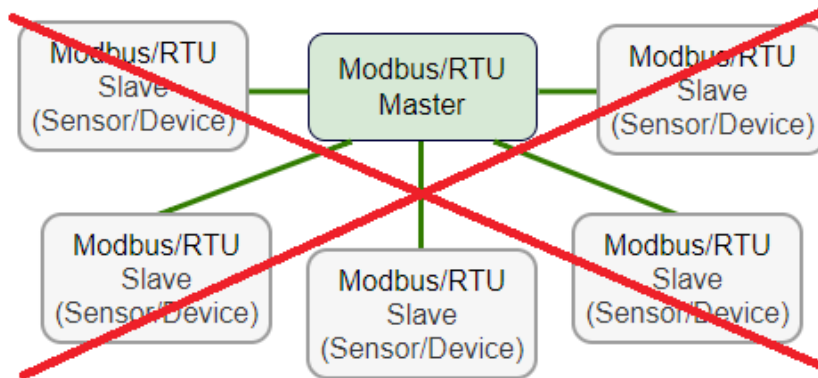

Avoid a star topology

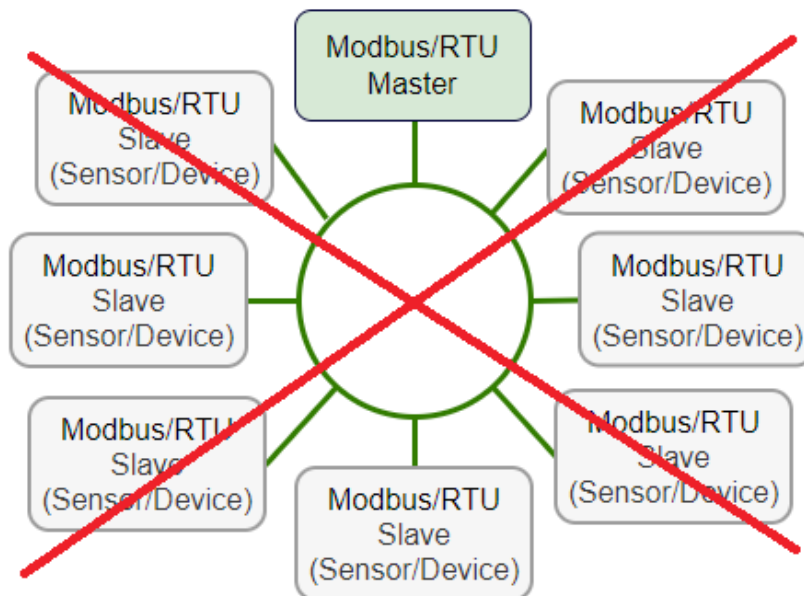

Avoid a ring topology

9.4 M-Bus Output

Communication parameters

Primary Address	: 1
Secondary Address	: 8-digit serial number of the device
Manufacturer Code	: 0x15C4
M-Bus version	: 1
Baud rate	: 2400
Response delay (ms)	: 7
Response timeout (ms)	: 100
Receive timeout (ms)	: 500

Value register

M-Bus Addr.	Description	Data bytes
1	Total consumption	4-byte
2	Flow	4-byte
3	M-Bus status	4-byte

9.5 Connection between S418 Outputs and Customer Equipment

This section provides figures to show how outputs supported by the S418 connect with the customer equipment.

In the following figures, the **SUTO Instrument** indicates the S418.

Analog output (Isolated)

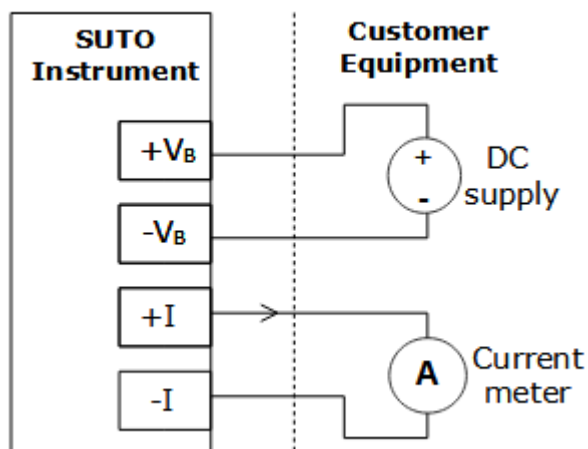

Pulse output (passive)

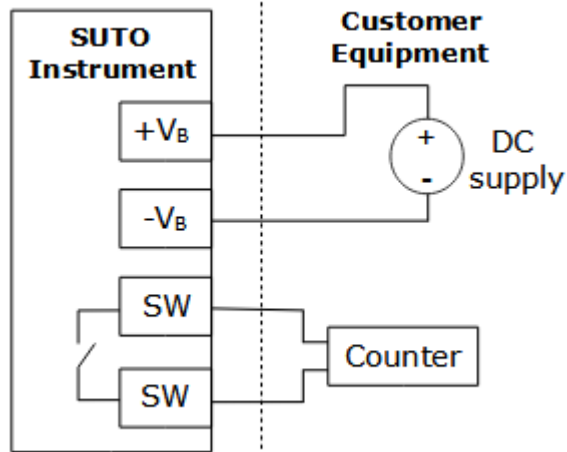

Modbus/RTU output

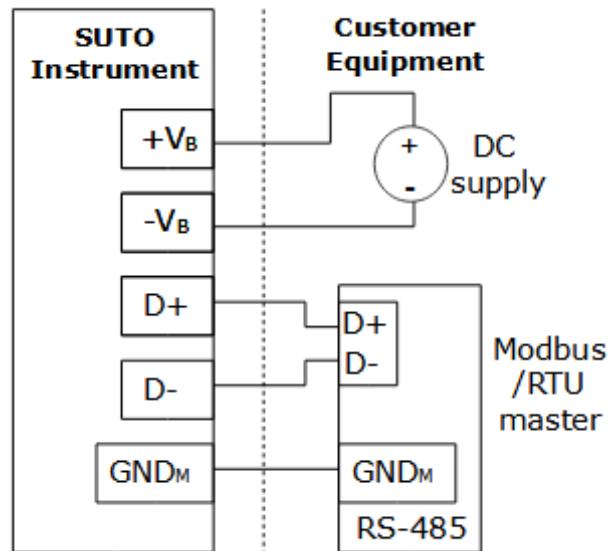

M-Bus output

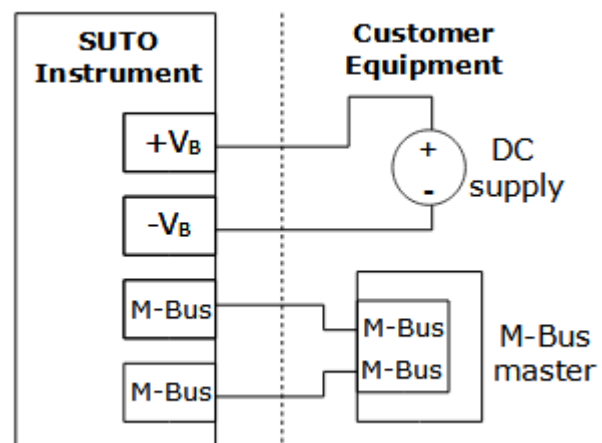

10 Configuration

To change any settings on the S418, please download and install the service App **S4C-FS** which is available on the Google Play store or our Website. This App works on any Android or iOS system with wireless connection supported.

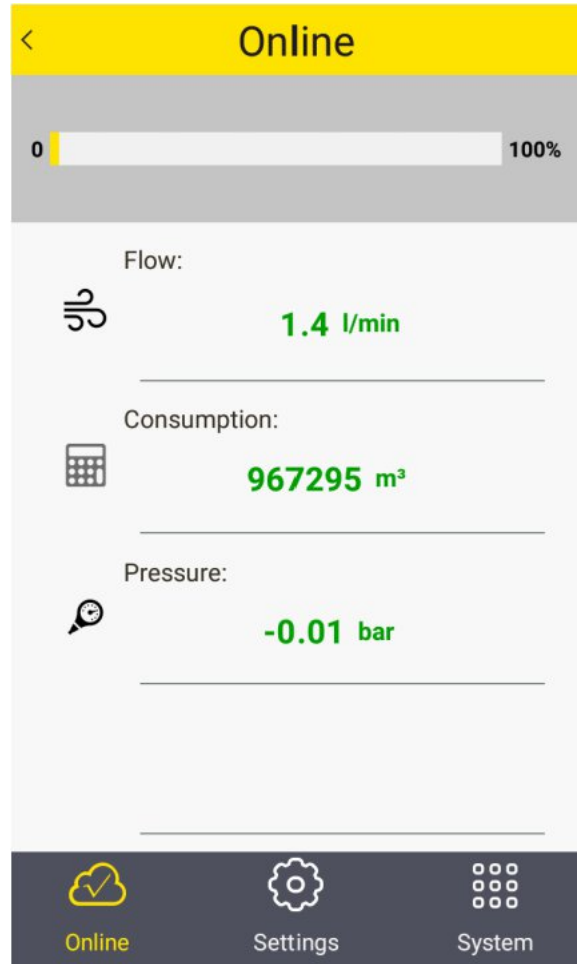

To be allowed to change settings, the App needs to scan the QR code attached on the side of the device head or on the calibration certificate. This ensures that only authorized users can access the device settings. For more information about instructions, see the *S4C-FS Instruction and operation manual*.



ATTENTION!

Changes on the settings may lead to wrong measurement results! Contact manufacturer in case you are not familiar with the settings.

11 Read and Analysis of Measurement Data

The S418 embeds the data logger to record the measured data. You can use the S4A, the free data analysis software to read and analyze the data.

11.1 Data Logger

Before you use the data logger, learn about how it works:

- You can use the S4C-FS App to enable or disable the data logger function and set a sampling rate as needed.
- By default the data logger is disabled. Once you enable the data logger, the S418 starts logging data. Once you disable the data logger, the S418 stops logging.
- The S418 saves all sampled data records into one file. Each record includes a time stamp and all measurement data sampled at this time point, such as flow, consumption, and pressure.
- The S418 log file supports up to 5.6 million records due to its memory size, which is equivalent to 64-day data at the one-second sampling rate.
- When the S418 runs out of memory, the new record will replace the oldest one.
- To read out the logs recorded in the S418 memory, install S4A (1.1.2 or later versions), which is a specialized log analysis software from SUTO, on a Windows-based computer. Also, connect the PC with the S418 through the USB port.
- Data records are saved in one file in the S418, S4A reads them out into one file as well unless the following situations occur:
 - When the sampling rate is changed, S4A reads out the data records into a different file.
 - When the S418 stops logging (for example, poweroff) and resumes in less than 24 hours, S4A still reads out the data records into one file; However, if the time gap is larger than 24 hours, S4A reads out the new data records to a different file.
- S4A enables you to have a graphic view on measurement data recorded in a log file.

11.2 Operations

11.2.1 Logger Configuration

You can control and configure the S418 data logger by using the S4C-FS App. Detailed steps are as follows.

1. Install and launch the **S4C-FS** App.

For more information, see the *S4C-FS Instruction and Operation Manual*.

2. On the S4C-FS App, access **Settings > Logger Settings** and then perform all logger-related operations as described below.

Parameter	Description
Logger Status	To start or stop the logger.
Start Date & Time	To view the time stamp of the first log recorded.
Stop Date & Time	To view the time stamp of the last log recorded.
Number of Samples	To view the number of log records in the S418 data logger.
Sampling Rate(mm:ss)	To specify the sampling rate.

11.2.2 Data Read-out and Analysis

To read, analyze and export the measurement data recorded in the S418, download and use the free analysis software S4A:

1. Download the S4A software from **Support > Downloads > Apps** on the SUTO Website (<http://www.suto-itec.com>).
2. Install the software on your computer by double clicking the downloaded EXE file.
3. Launch the S4A software.
4. Click **Detect** to detect and build the communication with the S418.
5. Disable the data logger in the S418.
Note: Before using the S4A software to read the log file from the S418, you must disabled the data logger so that the file can be read.
6. Click **Read** read out data records logged during a time period that you specify.

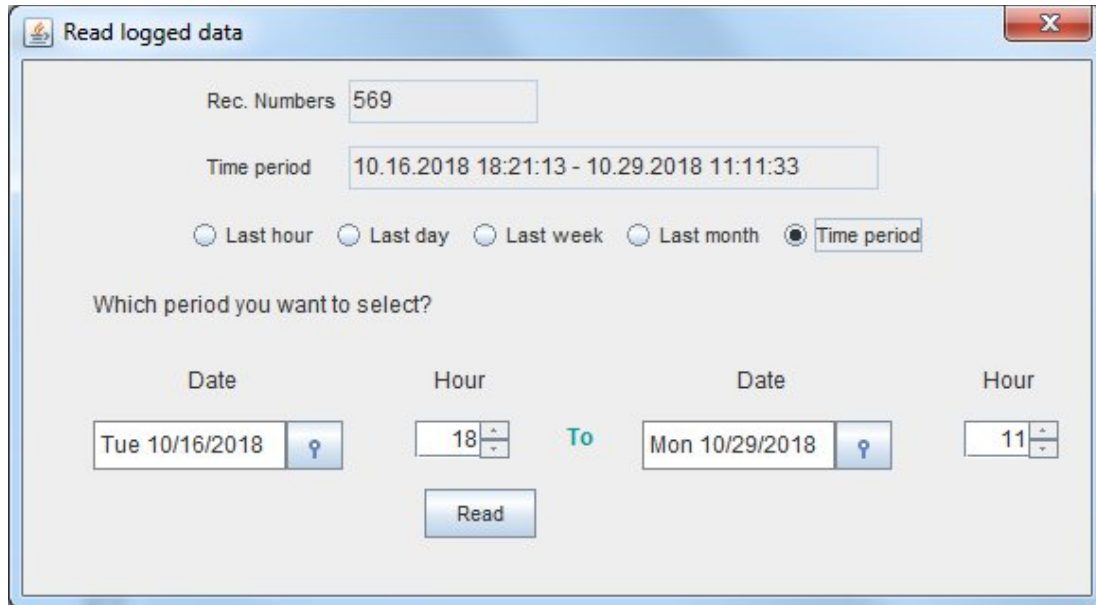

7. Click the **File** menu to have graphic views on measurement data in a log file; and if needed, to export this log file to the Excel or CSV format.

For more information about operations on S4A, click the **Help** button on the top right corner.

12 Calibration

The instrument is calibrated ex work. The exact calibration date is printed on the certificate which is supplied together with the instrument. The accuracy of the instrument is regulated by the on site conditions, parameters like oil, high humidity or other impurities can affect the calibration and furthermore the accuracy. However we recommend to calibrate the instrument at least once per year. The calibration is excluded from the instruments warranty. For this please contact the manufacturer.

13 Maintenance

To clean the instrument it is recommended to use distilled water or isopropyl alcohol only. If the contamination can not be removed the instrument must be inspected and maintained by the manufacturer.

14 Disposal of Waste



Electronic devices are recyclable material and do not belong in the household waste.

The device, the accessories and its packings must be disposed according to your local statutory requirements.

The dispose can also be carried by the manufacturer of the product, for this please contact the manufacturer.

SUTO iTEC GmbH

Grißheimer Weg 21
D-79423 Heitersheim
Germany

Tel: +49 (0) 7634 50488 00
Email: sales@suto-itec.com
Website: www.suto-itec.com

SUTO iTEC (ASIA) Co., Ltd.

Room 10, 6/F, Block B, Cambridge Plaza
188 San Wan Road, Sheung Shui, N.T.
Hong Kong

Tel: +852 2328 9782
Email: sales.asia@suto-itec.com
Website: www.suto-itec.com

SUTO iTEC Inc.

5460 33rd St SE
Grand Rapids, MI 49512
USA

Tel: +1 (616) 800-7886
Email: sales.us@suto-itec.com
Website: www.suto-itec.com

All rights reserved ©

Modifications and errors reserved

S418_IM_EN_V2026-1