

# Instruction and Operation Manual

# S461

## Ultrasonic Flow Meter for Liquids (Clamp-on)



Dear Customer,

Thank you for choosing our product.

Before you start up the device please read this manual in full and carefully observe instructions stated in this manual. The manufacturer cannot be held liable for any damage that occurs as a result of non-observance or non-compliance with this manual.

Should the device be tampered with in any manner other than a procedure that is described and specified in the manual, the warranty is void and the manufacturer is exempt from liability.

The device is destined exclusively for the described application.

SUTO offers no guarantee for the suitability for any other purpose. SUTO is also not liable for consequential damage resulting from the delivery, capability or use of this device.

Revision: 2025-4

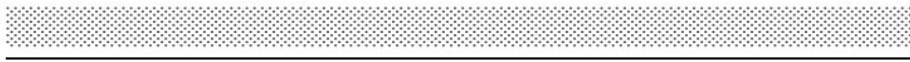

Last modifications: December, 2025

## Table of Contents

1	Safety Instructions.....	5
2	Registered Trademarks.....	6
3	RF Exposure Information and Statement.....	8
4	Applications.....	9
5	Features .....	10
6	Technical Data.....	11
	6.1 Measurement.....	11
	6.2 Signal and Interface.....	12
	6.3 General Data.....	12
	6.4 Operating Conditions.....	13
	6.5 Flow Range.....	14
7	Dimensional Drawing.....	15
8	Determination of Installation Point.....	18
9	Installation.....	21
	9.1 Install S461 Main Unit.....	24
	9.2 Electrical Connection.....	25
	9.2.1 M12 Connection Pins.....	25
	9.2.2 Ethernet Connection.....	27
	9.2.3 M8 Connection Pins.....	29
	9.3 Connection between S461 Outputs and Customer Equipment....	29
	9.4 Set S461 by S4C-US App.....	33
	9.4.1 Install S4C-US App .....	33
	9.4.2 Scan QR Code .....	33
	9.4.3 Basic Settings.....	34
	9.4.4 Installation Settings.....	36
	9.5 Transducer Installation .....	37
	9.5.1 Install a Transducer.....	37
	9.5.2 Remove a Transducer.....	39
	9.5.3 Install a Transducer with Mounting Fixture.....	39
	9.6 Final Check.....	41
	9.7 LED Indicators.....	43
	9.8 Values on Display.....	43
	9.9 Other Issues and Recommended Actions.....	45
10	View Measurement Data .....	47
	10.1 Online.....	47
	10.2 Consumption.....	48
11	Other Settings.....	49
	11.1 Factory Settings.....	49
	11.1.1 Fixed Delay.....	49
	11.1.2 Cut-Off Velocity.....	49
	11.1.3 Bi-directional Flow.....	49

---

11.1.4	Delta T Cut-Off.....	49
11.1.5	Min velocity, Max velocity.....	49
11.2	Totalizer Settings.....	49
11.3	Alarm Settings.....	50
11.4	Output Settings.....	50
11.4.1	Modbus/RTU Output Settings.....	50
11.4.2	TCP/IP Output Settings.....	50
11.4.3	Analog Output Settings.....	51
11.4.4	Pulse Output Settings .....	51
11.4.5	Alarm Output Settings.....	53
11.5	Calibration.....	53
11.5.1	Zero Flow Calibration.....	53
11.5.2	T-Offset Calibration.....	53
11.5.3	User Calibration.....	54
11.6	Logger Settings.....	54
12	System Functions.....	54
12.1	Sensor Info.....	54
12.2	Language.....	54
12.3	Logger Status.....	54
12.4	Logger Readout.....	54
12.5	System Log.....	55
12.6	Wireless Sensor Connection .....	55
12.7	App Version.....	55
13	Calibration.....	56
14	Maintenance.....	56
15	Disposal of Waste.....	56
16	Appendix A – Modbus Register Table.....	57
16.1	Modbus Interface.....	57
16.2	Modbus Registers.....	59
17	Appendix B – Sound Speed of Pipe Material.....	60
18	Appendix C – Install Insertion PT1000.....	61
18.1	Items for Installation.....	61
18.2	Installation Requirements.....	61
18.3	Installation Steps.....	62

## 1 Safety Instructions

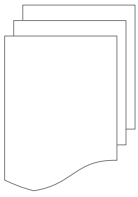

**Please check if this instruction manual matches with the product type.**

Please observe all notes and instructions indicated in this manual. This manual contains essential information that must be observed before and during installation, operation and maintenance. Therefore this manual must be read carefully by the technician as well as by the responsible user or qualified personnel.

This instruction manual must be available at the operation site of the product at any time. In case of any obscurities or questions regarding this manual or the product, please contact the manufacturer.

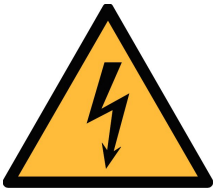

### **WARNING!**

#### **Voltage used for supply!**

**Any contact with energized parts of the product, may lead to a electrical shock which can lead to serious injuries or even death!**

- Consider all regulations for electrical installations.
- The system must be disconnected from any power supply during maintenance work.
- Any electrical work on the system is only allowed by authorized qualified personal.



### **WARNING!**

#### **Permitted operating parameters!**

**Observe the permitted operating parameters, any operation exceeding this parameters can lead to malfunctions and may lead to damage on the instrument or the system.**

- Do not exceed the permitted operating parameters.
- Make sure the product is operated in its permitted limitations. Store and operate the product at the permitted temperature and pressure.
- The product must be maintained and calibrated frequently, at least annually.

**General safety instructions**

- It is not allowed to use the product in explosive areas.
- Please observe the national regulations before/during installation and operation.

**Remarks**

- It is not allowed to disassemble the product.
- Always use spanner to mount the product properly.



**ATTENTION!**

**Measurement values can be affected by malfunction!**

**The product must be installed properly and frequently maintained, otherwise it may lead to wrong measurement values, which can lead to wrong results.**

- Do not exceed the maximum operation temperature of the transducer.

**Storage and transportation**

- Make sure that the transportation temperature of the device is between -30°C ... +70°C.
- For transportation it is recommended to use the packaging which comes with the device.
- Please make sure that the storage temperature of the device is between -10°C ... +50°C.
- Avoid direct UV and solar radiation during storage.
- For the storage the humidity must be <90% with no condensation.

**2 Registered Trademarks**

<b>Trademark</b>	<b>Trademark owner</b>
SUTO®	SUTO ITEC
MODBUS®	Modbus Organization, Hopkinton, USA
Android™, Google Play	Google LLC

### 3 RF Exposure Information and Statement

This equipment complies with FCC RF radiation exposure limits set forth for an uncontrolled environment. This equipment should be installed and operated with minimum distance of 20 cm between the radiator and your body.

This device complies with part 15 of the FCC rules. Operation is subject to the following two conditions: (1) this device might not cause harmful interference, and (2) this device must accept any interference received, including interference that might cause undesired operation.

**Remark:** The manufacturer is not responsible for any radio or TV interference caused by unauthorized modifications to this equipment. Such modifications could void the user's authority to operate the equipment.

**Remark:** This equipment has been tested and found to comply with the limits for a Class B digital device, pursuant to part 15 of the FCC Rules. These limits are designed to provide reasonable protection against harmful interference in a residential installation. This equipment generates uses and can radiate radio frequency energy and, if not installed and used in accordance with the instructions, might cause harmful interference to radio communications. However, there is no guarantee that interference will not occur in a particular installation. If this equipment does cause harmful interference to radio or television reception, which can be determined by turning the equipment off and on, the user is encouraged to try to correct the interference by one or more of the following measures:

- Reorient or relocate the receiving antenna.
- Increase the separation between the equipment and receiver.
- Connect the equipment into an outlet on a circuit different from that to which the receiver is connected.
- Consult the dealer or an experienced radio/TV technician for help.
- This device and its antenna(s) must not be co-located or operating in conjunction with any other antenna or transmitter.

## 4 Applications

The SUTO Ultrasonic Flow Meter for Liquids has all it takes to measure reliable, easy and accurate flow and consumption of liquids. Based on the transit time technology this flow meter comes with unique features and outstanding performance.

The transducers are simply clamped onto the outside of the pipe and never come in contact with the fluid. The main unit can be installed onto the pipe, at the wall or onto a DIN rail.

The configuration and setup is made through the wireless smart phone App S4C-US, which can be downloaded for free from the SUTO website, Google Play Store and the Apple App Store.

The app allows the user to set up the device as well as reading live values, logger configuration and logger data read out.

By adding 2 clamp-on temperature sensors the Energy Meter Version monitors the efficiency of heat ex-changers.

The S461 comes also as portable version in a transport case.

The liquids that S461 can measure include the following:

- Water
- Sea water
- Kerosene
- Octane (Gasoline)
- Fuel Oil
- Propane
- Iso-Butane
- Diesel Oil
- Caster Oil
- Peanut Oil
- Alcohol
- Others (please enter sonic speed)

The S461 flow meter is mainly used in an industrial environment. It is not developed to be used in explosive areas.

## 5 Features

- Uses the proven clamp-on transit-time correlation technique.
- Easy to install for permanent and temporary installations.
- User friendly configuration through the dedicated mobile App.
- A wide range of pipe sizes from DN40 to DN1200.
- Data analysis via the S4A software.
- Through additional temperature sensor inputs S461 can be used as energy meter to monitor heat exchanger.
- Bi-directional flow measurement.
- Measurement data of each channel can be viewed on both the S461 display and the S4C-US App.
- Consumption can be viewed on a daily, weekly, or monthly basis in a bar chart or in a tabular form through the S4C-US App.
- Measurement log files can be downloaded to your PC through the free S4A software, or by the mobile phone App S4C-US.

## 6 Technical Data

### 6.1 Measurement

 FCC ID: 2ABN2-BG22B1	
<b>Flow</b>	
Accuracy	1.0% of reading $\pm$ 0.01 m/s
Selectable units	Metric: m <sup>3</sup> /h, m <sup>3</sup> /min, l/min Imperial: cfm, cfs, USG/min, IG/min, bbl/min
Measuring range	0.03 ... 12 m/s
Repeatability	0.2% of reading
Transducer	Ultrasonic transducer for flow meter <ul style="list-style-type: none"> <li>• UT-S: for normal temperature</li> <li>• UTH-S: for high temperature</li> </ul>
Sampling rate	5 samples / sec
Response time (t <sub>90</sub> )	0.1 sec
<b>Velocity</b>	
Selectable units	Metric: m/s Imperial: ft/min
<b>Consumption</b>	
Selectable units	Metric: m <sup>3</sup> , l Imperial: cf, IG, UG, bbl
<b>Temperature</b>	
Accuracy	$\pm$ 0.5K
Selectable units	Metric: °C, Imperial: °F
Measuring range	-10°C ... +130°C
Sensor	Pt1000
<b>Energy Flow</b>	
Selectable units	Metric: GJ/h, kJ/h, kcal/h, kW, mW Imperial: MBtu/h, Btu/h
<b>Energy</b>	
Selectable units	Metric: GJ, kJ, kcal, kWh, MWh Imperial: MBtu, Btu

## 6.2 Signal and Interface

<b>Analog output (Optional)</b>	
Signal	4 ... 20 mA (4-wire), isolated
Scaling	0 ... max flow, freely adjustable
Load	max. 250 Ohm
Update rate	100 msec
<b>Pulse output (Optional)</b>	
Signal	Switch output, normally open, nominal value: 24 VDC/0.5 A
Scaling	1 pulse per consumption unit (selectable)
<b>Fieldbus</b>	
Protocol	Modbus/RTU (Standard) Modbus/TCP and PoE (Optional)
<b>Supply</b>	
Voltage supply	20 ... 28 VDC
Current consumption	150 mA @ 24 VDC

## 6.3 General Data

<b>Configuration</b>	
Wireless	S4C-US App for mobile phones
<b>Display</b>	
Size/resolution	2.4" color (240 x 320) graphic display, 1 touch button
<b>Data Logger</b>	
Storage	8 Mio. values
<b>Material</b>	
Main Casing	PC + ABS
Transducer	UT-S: Industrial synthetic plastics UTH-S: Aluminum
<b>Miscellaneous</b>	
Electrical connection	2 x M12 (4-pole): transducer 1 x M12 (5-pole): Signals/Supply 1 x M12: 5-pole for Analog/Pulse (standard),

	or 8-pole x-coded for Modbus/TCP 2 x M8 (4-pole): Pt1000 (Energy Meter Version)
Protection class	Main casing: IP65. Transducer: IP68
Approvals	CE, RoHS, FCC
Weight	1.2 kg
Dimensions	Main unit: 124 x 102 x 70 mm UT-S transducer: 64 x 30 x 27 mm UTH-S transducer: 68 x 34 x 34 mm

#### 6.4 Operating Conditions

Fluids	All acoustically conductive liquids with less than 10% gaseous
Medium temperature	-40°C ... +130°C
Ambient temperature	Main unit: 0°C... +50°C UT-S transducer: 0°C... +80°C UTH-S transducer: -40°C... +130°C
Ambient humidity	< 99% rH
Storage temperature	-30°C ... +70°C
Transport temperature	-30°C ... +70°C
Pipe sizes	DN40 ... DN1200

## 6.5 Flow Range

DN	OD	Max flow		
		l/min	m <sup>3</sup> /h	cfm
40	48	905	54	32
50	60	1,414	85	50
65	76	2,389	143	84
80	88	3,619	217	128
100	114	5,655	339	200
125	139	8,835	530	312
150	165	12,723	763	449
200	219	22,618	1,357	799
250	273	35,341	2,121	1,248
300	323	50,891	3,054	1,797
500	508	141,365	8,482	4,992
1,000	1,016	565,458	33,929	19,970
1,200	1,219	814,260	48,858	28,756

### Remarks:

DN: nominal inner diameter

OD: outer diameter (depends on standard and material)

### 7 Dimensional Drawing

#### Main unit

unit: mm

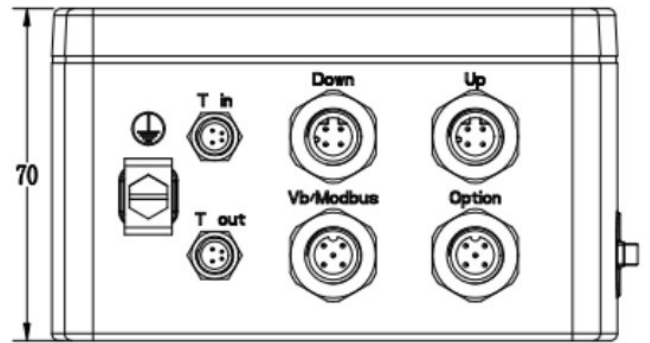
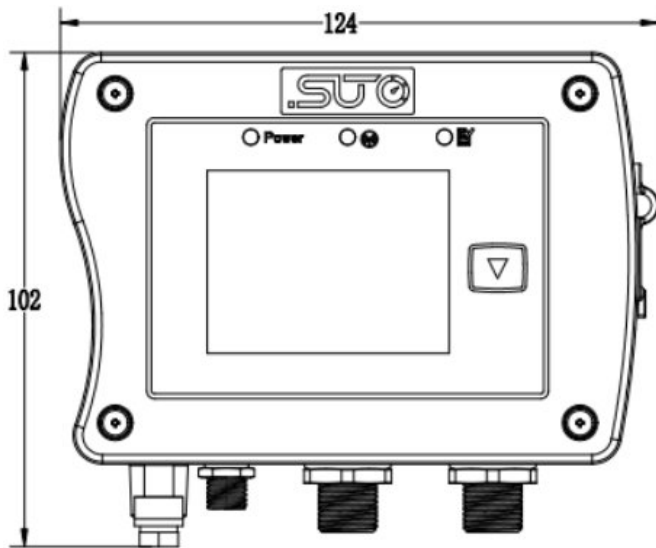

#### Ultrasonic transducer UTH-S

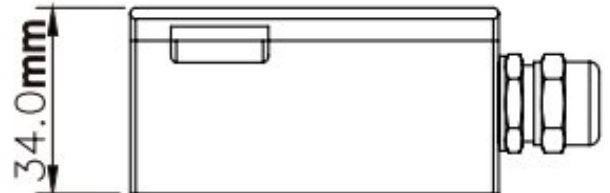
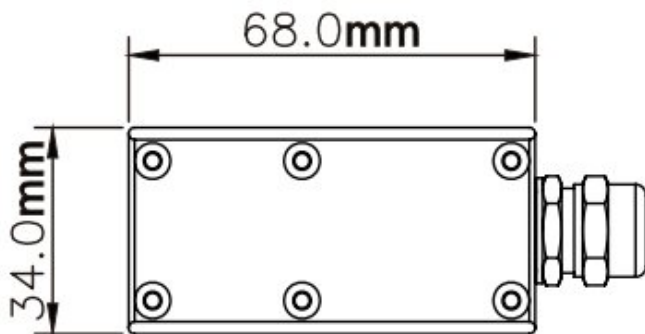

#### Ultrasonic transducer UT-S

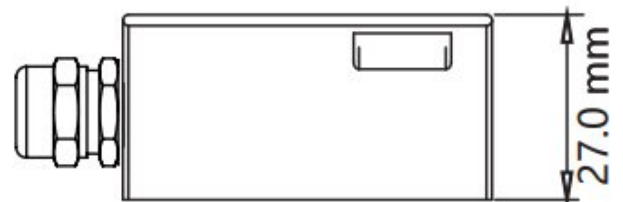
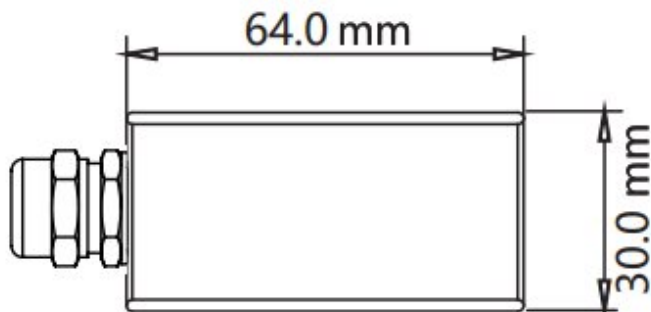

### Transducer mounting fixture A695 4617, for installation of Ultrasonic transducer UT-S

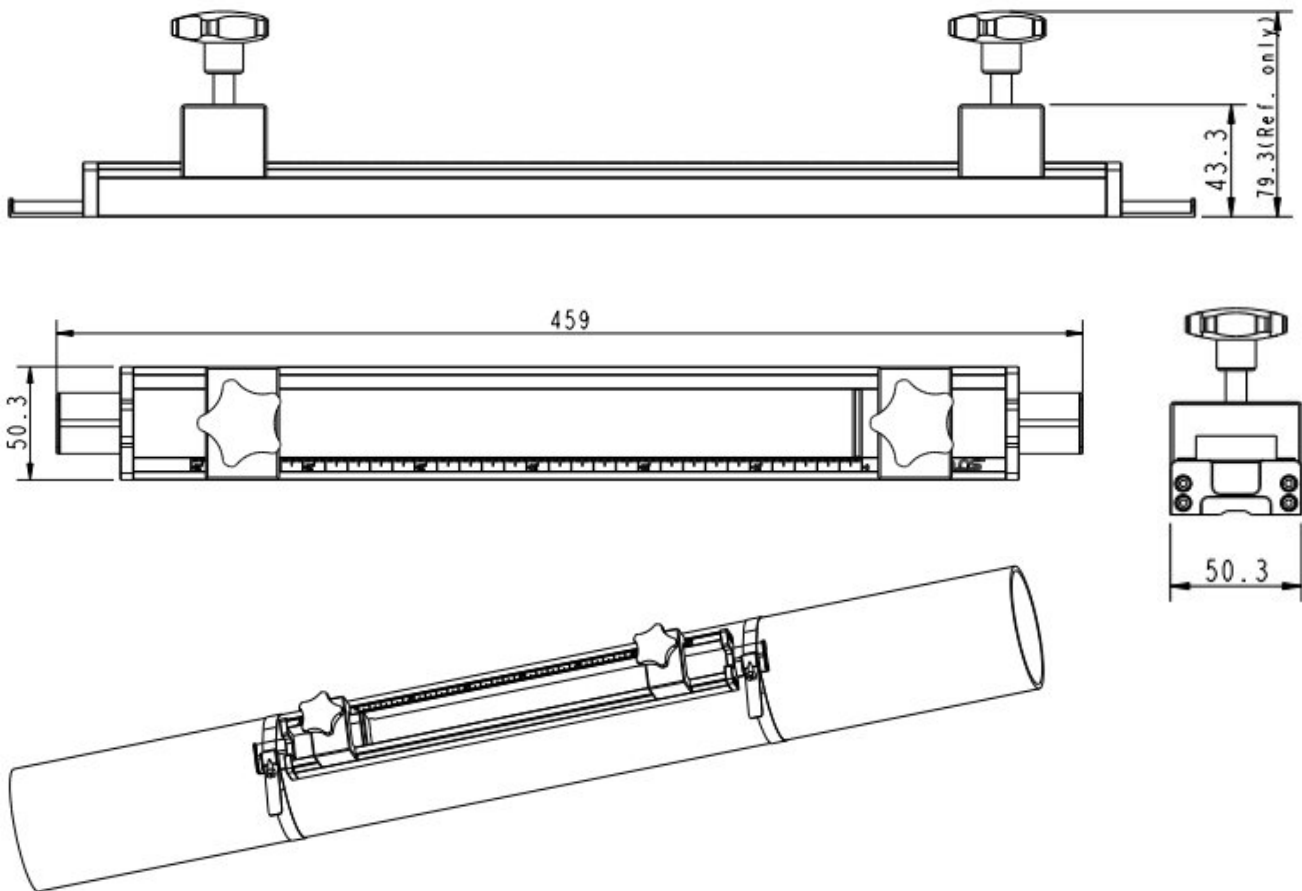

**Transducer mounting fixture A695 4618, for installation of Ultrasonic transducer UTH-S**

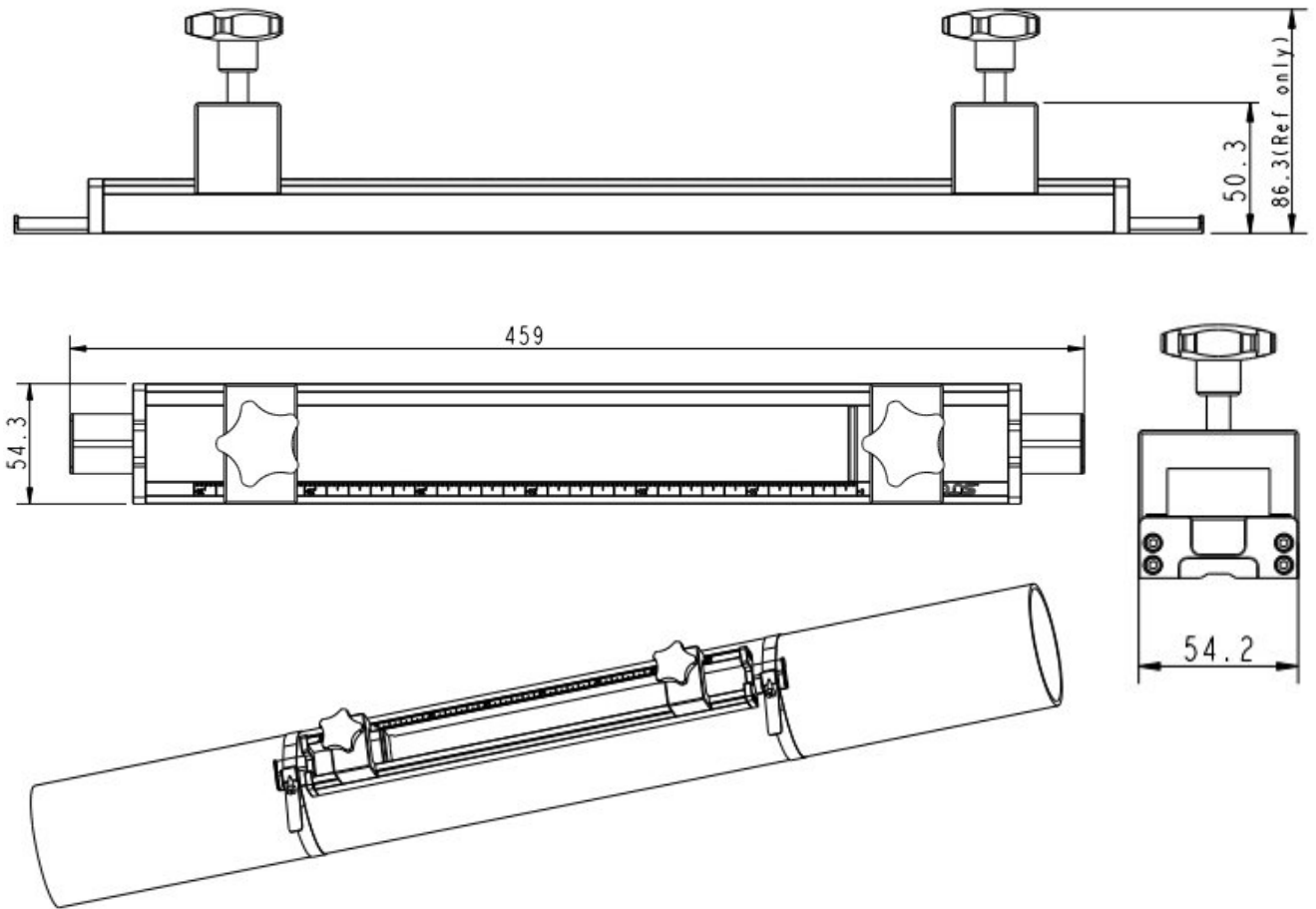



## 8 Determination of Installation Point

To maintain the accuracy stated in the technical data, the ultrasonic transducers must be clamped on a straight pipe with unhindered flow characteristics. The pipe can be in vertical or horizontal position.

Unhindered flow characteristics are achieved if the section in front of the transducer (upstream) and behind the transducer (downstream) are sufficiently long, absolutely straight and free of obstructions such as edges, seams, curves, and so on.

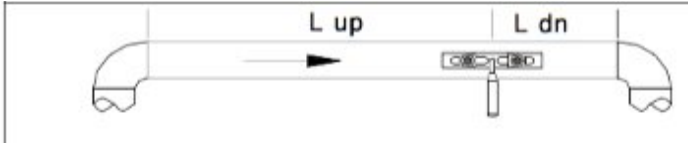
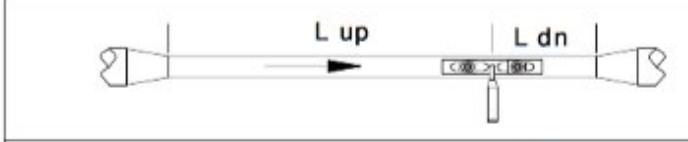
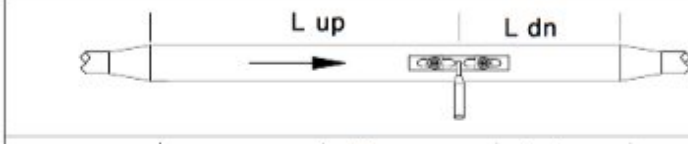
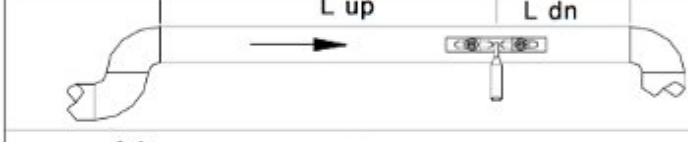
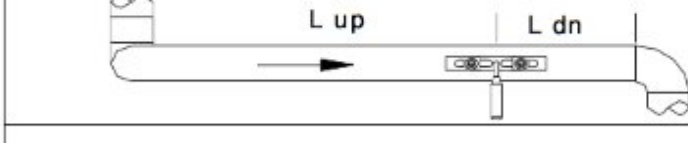
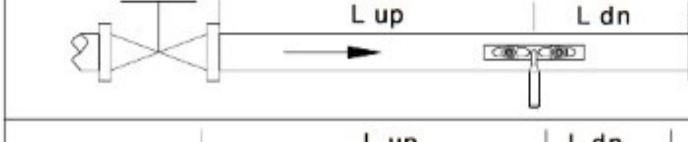
The following table shows examples of optimum installation locations.

Piping configuration and transducer position	Upstream dimension	Downstream dimension
	Lup x diameter	Ldn x diameter
	10D	5D
	10D	5D
	10D	5D
	12D	5D
	20D	5D
	20D	5D
	30D	5D

Principles to select an optimum location:

- Install the transducers on a long straight pipe. The longer the better and make sure that the pipe is completely full of liquid. The following conditions are identified as full of liquid:

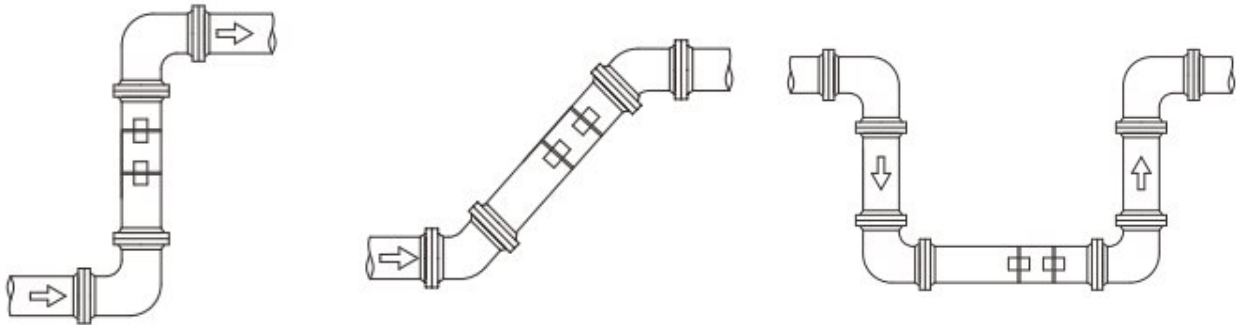

Vertical upward flow

Inclined upward flow

Lowest position of pipe

- It's recommended to place the transducers not on top of the pipe, but rather at a side position to avoid air bubbles that may occur on top of the pipe can effect the measurement.
- Make sure that the temperature on the location does not exceed the permitted temperature range for the transducers. Generally, the closer to the room temperature the better.
- Take the pipe fouling into consideration. Select a straight and relatively new pipe. If the condition is not satisfying, consider the fouling thickness as part of the liner for a more accurate result.

**Remarks:**

Some pipes have a kind of plastic liner. Between the outer pipe and the liner there may be a certain thickness difference that will prevent the ultrasonic waves from direct traveling. Such conditions will make the measurement impossible. Try to avoid this kind of pipes whenever possible.



**ATTENTION!**

- **The pipe at the installation point must not vibrate significantly, otherwise the pipe must be reinforced.**
- **Wrong measurement may occur if the transducers are not installed correctly.**
- The flow meter is for indoor use only! At an outdoor installation, the device must be protected from solar radiation and rain.
- It is strongly recommended not to install S461 permanently in wet environment.

## 9 Installation

Make sure that all components listed below are included in your package.

Qty	Description	Order No.
1	S461 Ultrasonic Flow Meter for Liquids main unit <b>or</b> S461 Ultrasonic Flow and Energy Meter for Liquids main unit	D695 4610  D695 4611
1	UT-S, Ultrasonic transducer pair (includes coupling agent) <b>or</b> UTH-S, Ultrasonic transducer pair (includes coupling agent)	A4610  A4611
1	Worm gear clamps <b>or</b> Ratchet strap (portable unit)	Depending on your order  A695 4608
1	USB cable, USB 2.0, A-male to type C-male	A553 0143
1	Instruction manual	N/A
1	S4C-US mobile App	To be downloaded from SUTO website, Apple store or Google play

Detailed explanations of items above and other various option, accessories available are described as below.

Order No.	Description
D695 4610	S461 Ultrasonic Flow Meter for Liquids main unit, USB, data logger and display
D695 4611	S461 Ultrasonic Flow and Energy Meter for Liquids main unit, USB, data logger, display and 2 additional M8 temperature inputs
<b>Main unit mounting</b>	
A4603	Pipe/Wall mounting plate (for pipe mounting please order worm gear clamp separately)
A4604	35 mm DIN hat rail mounting plate
A4602	No mounting

<b>Output options</b>	
A4605	Modbus/RTU
A4606	Modbus/RTU + 4 ... 20 mA, Pulse / Alarm
A4607	Modbus/RTU + Modbus/TCP
<b>Camp-on ultrasonic transducers for flow meter and energy meter</b>	
A4610	UT-S, Ultrasonic transducer pair, DN40 ... DN1200, 5 m cable, M12 connector, 0 ... +80°C, IP68 (includes coupling agent)
A4611	UTH-S, Ultrasonic transducer pair, DN40 ... DN1200, 5 m cable, M12 connector, -40 ... +130°C, IP68 (includes coupling agent)
<b>Temperature sensors for energy meter</b>	
A4616	Clamp-on temperature sensor pair, 5 m cable, M8 connector, -10 ... +130°C, IP42, for S461 energy meter only (including worm gear clamps)
A4617	Insertion temperature sensor pair, 5 m cable, PT1000 Class B, M8 connector, -10 ... +250 °C, 6 x 150 mm sensor tube, for S461 energy meter only
<b>Transducer unit mounting</b>	
	Worm gear clamp for sensor and main unit installation on pipes
A695 4601	DN40 ... DN65 (2 pieces)
A695 4602	DN80 ... DN100 (2 pieces)
A695 4603	DN125 ... DN150 (2 pieces)
A695 4604	DN200 ... DN300 (2 pieces)
A695 4605	DN350 ... DN500 (2 pieces)
A695 4608	Ratchet strap for temporary sensor installations (portable unit), DN40 ... DN500 (2 pieces)

### Optional installation accessories

<b>Transducer unit mounting (Guided mounting fixture)</b>	
A695 4617	Transducer mounting fixture for UT-S ultrasonic flow transducer pair, uses worm gear clamps to fix, the max. supported pipe size is DN300
A695 4618	Transducer mounting fixture for UTH-S high-temperature

	ultrasonic flow transducer pair, uses worm gear clamps to fix, the max. supported pipe size is DN300
<b>Insertion temperature sensor unit mounting (Compression fitting)</b>	
A554 6003	Compression fitting 6 mm, G1/2", PTFE ring, 0.6 MPa
A554 6004	Compression fitting 6 mm, G1/2", metal ring, 1.6 MPa

**Other accessories**

<b>Order No.</b>	<b>Description</b>
A553 0104	Sensor cable, 5 m, with M12 connector, open wires
A553 0105	Sensor cable, 10 m, with M12 connector, open wires
A554 0108	Mains unit 100...240 VAC/24 VDC, 0.83 A for SUTO sensors, 1.5 m cable, M12 connector
A554 4625	Transport casing S461 dimensions: 560 x 450 x 160 mm (portable unit)
A553 0159	S461 flow transducer extension cable pair, 5 m, M12 4-pole male/female
A553 0163	S461 temperature sensor extension cable pair, 5 m, M8 4-pole male/female
A695 4610	Coupling agent for sensor installation, 65 g
A553 0154	Cable to connect power bank, 1.8 m, USB-C connector for power bank, M12 connector
P554 0009	Ultrasonic thickness meter

**Calibration and Services**

<b>Order No.</b>	<b>Description</b>
R200 4614	Calibration insertion temperature sensor with S461 to achieve system accuracy of $\pm 0.15$ K at calibration point (Calibration range: -10 ... 80 ) °C
R200 4610	Calibration S461 together with transducer pair

## 9.1 Install S461 Main Unit

1. Install the S461 main unit at the designated location. Through optional accessories it can be mounted on the wall, on the pipe or on a DIN hat rail.

Mounted on the wall

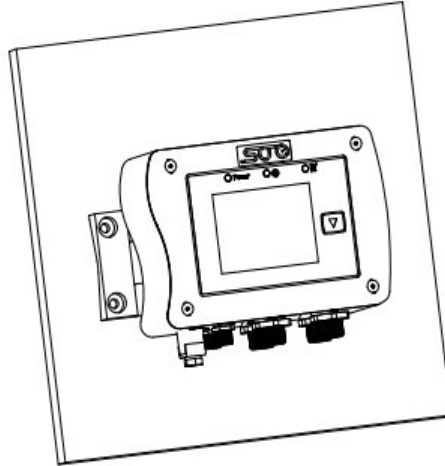

Mounted on the pipe

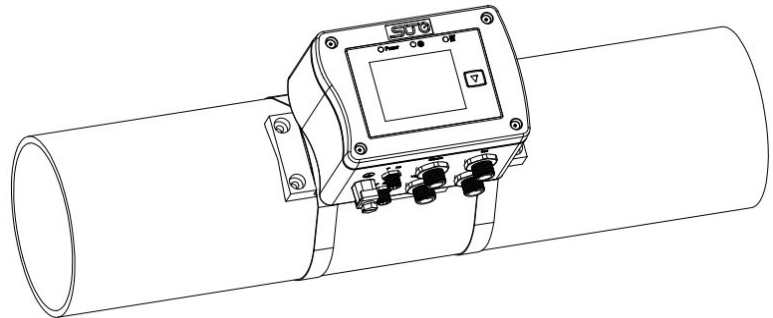

Mounted on a DIN  
hat rail

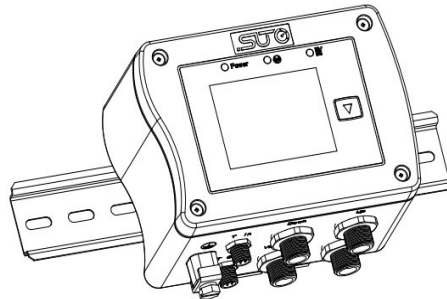

2. Connect the transducers, the power supply and temperature sensors to the designated connectors, as described in the table below.

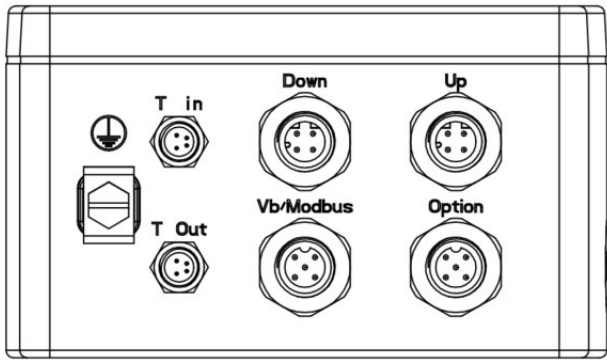

Connector arrangement

**Note:** When the S461 is used as a flow meter, there are no **T in** and **T out** connectors.

**T in:** Connect to the inlet temperature sensor.

**T out:** Connect to the outlet temperature sensor.

**Down:** Connect to the downstream transducer (cable with blue sleeve).

**Up:** Connect to the upstream transducer (cable with red sleeve).

**Vb/Modbus:** Connect to the Modbus/RTU output/power supply.

**Option:** Connect to the Modbus/TCP output when it is a X-coded connector; connect to analog/pulse output when it is a A-coded connector.

- The S461 comes with an optional Earth connection, which is recommended to be used if the unit is operated in an environment with high electrical interference. The  terminal in the connector arrangement diagram is used for Earth connection.

## 9.2 Electrical Connection

The S461 comes with four M12 connectors, two M8 connectors (for Flow and Energy meter).

### 9.2.1 M12 Connection Pins

The S461 supports the following types of M12 connectors:

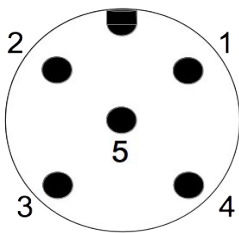

5-pole connector, male  
(View onto the connector)

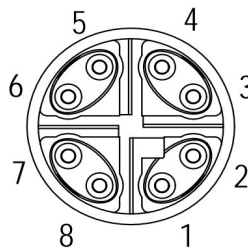

8-pole connector for Ethernet connection, male  
(View onto the connector)



4-pole connector, male  
(View onto the connector)

The following table lists the available M12 connectors for signal output:

P/N	Output	Connector name	Connector type
	Modbus/RTU (Standard)	Vb/Modbus	5-pole M12
A4606	4 ... 20 mA + Pulse/Alarm (Optional)	Option	5-pole A-coded M12 for analog and pulse/alarm or 8-pole X-coded M12 for Modbus/TCP
A4607	Modbus/TCP (Optional)		

The following table lists the M12 connectors for transducer connection:

Transducer name	Connector name	Connector type
UT-S or UTH-S ultrasonic transducer pair	Down	4-pole M12
	Up	4-pole M12

### M12 5-pole assignment

Output Type	Connector	Pin 1	Pin 2	Pin 3	Pin 4	Pin 5
Modbus/RTU	Vb/Modbus	GND <sub>M</sub>	-V <sub>B</sub>	+V <sub>B</sub>	D+	D-
4 ... 20 mA + pulse (P/N: A4606)	Option	NA	SW	SW	+I	-I
Color	/	Brown	White	Blue	Black	Gray

### Legend to pin assignment (M12 5-pole)

GND <sub>M</sub>	Ground for Modbus/RTU	SW	Isolated pulse output (switch)
-V <sub>B</sub>	Negative supply voltage	D+	Modbus/RTU data +
+V <sub>B</sub>	Positive supply voltage	D-	Modbus/RTU data -
+I	Positive 4 ... 20 mA signal (isolated)	NA	Not applicable
-I	Negative 4 ... 20 mA signal (isolated)		

### M12 8-pole assignment

The connector "Option" can be an 8-pole X-coded M12. At this point, it is used to provide Modbus/TCP output (P/N: A4607). Regarding how it fits in the RJ-45 connector, see section 9.2.2.

### M12 4-pole assignment

Connector	Pin 1	Pin 2	Pin 3	Pin 4
Down	DN+	NC	GNDsensor	DN-
Up	UP+	NC	GNDsensor	UP-

### Legend to pin assignment (M12 4-pole)

DN+	DN transducer positive
DN-	DN transducer negative
UP+	UP transducer positive
UP-	UP transducer negative
GNDsensor	Transducer GND
NC	Not connected



#### ATTENTION!

**Do not screw the M12 connector using force. Otherwise it might damage the connecting pins.**

### 9.2.2 Ethernet Connection

The S461 can be powered by the following ways:

- Using the connector Vb/Modbus.
- Using the Power over Ethernet (PoE) function, which is integrated into the Ethernet connection on Option Modbus/TCP.

To power the unit via PoE, a network switch that supports PoE is needed. PoE comes into two standards:

- Type A: The PoE switch powers the device via Pair 2 (Pin 1 and Pin 2) and Pair 3 (Pin 3 and Pin 6)
- Type B: The PoE switch powers the device via Pair 1 (Pin 4 and Pin 5) and Pair4 (Pin 7 and Pin 8)

The S461 supports both types.

### Connection cable – M12 X-coded to RJ-45

When the Modbus/TCP is chosen as the S461 output, a 5 m 8-pole cable is supplied in the delivery package. The cable has the M12 and RJ-45 plugs on the ends. The RJ-45 is used to connect the S461 to a PoE switch.

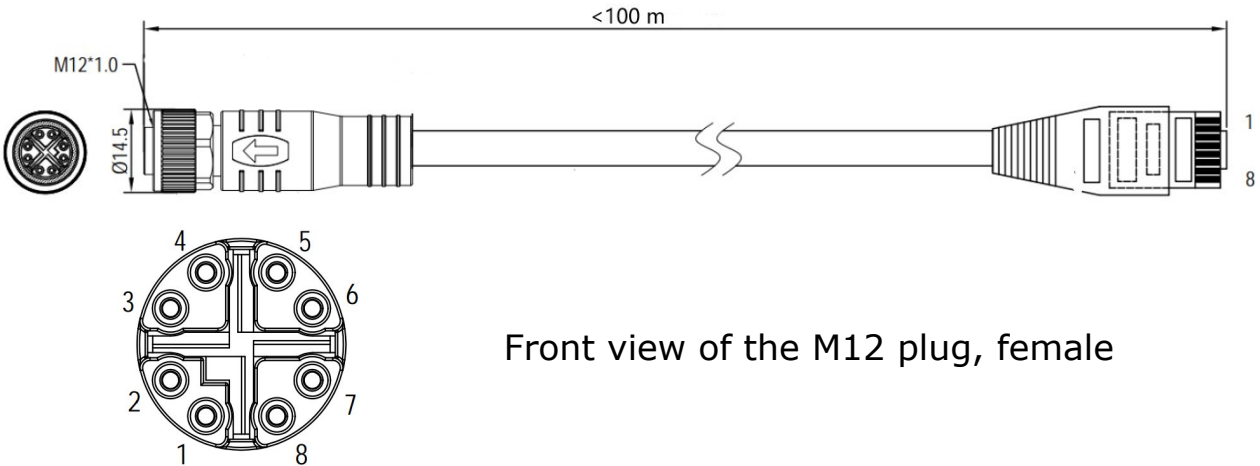

Front view of the M12 plug, female

The 8-position pin/pair assignment on the RJ-45 side must comply with the T568B wiring method. The S461 does not support the T568A wiring method.

M12 X-code	RJ-45	Signal	Color code	Pair designation
1	1	Tx+ / +V <sub>B</sub> / -V <sub>B</sub>	White-Orange (W-O)	Pair 2
2	2	Tx- / +V <sub>B</sub> / -V <sub>B</sub>	Orange (O)	
3	3	Rx+ / -V <sub>B</sub> / +V <sub>B</sub>	White-Green (W-G)	Pair 3
4	6	Rx- / -V <sub>B</sub> / +V <sub>B</sub>	Green (G)	
5	7	NA / -V <sub>B</sub>	White-Brown (W-BR)	Pair 4
6	8	NA / -V <sub>B</sub>	Brown (BR)	
7	5	NA / +V <sub>B</sub>	White-Blue (W-BL)	Pair 1
8	4	NA / +V <sub>B</sub>	Blue (BL)	

### 9.2.3 M8 Connection Pins

The S461 can be used as an energy meter. It comes with two M8 connectors: **T in** and **T out**, which connect to the inlet temperature sensor and outlet temperature sensor respectively. The temperature sensors (Pt1000) come with 5 m cable and M8 connector.

#### Pin assignment connector plug M8

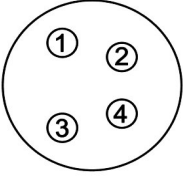
	Connector	Pin 1	Pin 2	Pin 3	Pin 4
	T in	PT1000	NC*	PT1000	NC*
	T out	PT1000	NC*	PT1000	NC*
Wire color		Red		Black	

\*NC: not connected



#### ATTENTION!

**Do not screw the M8 plug using force. Otherwise, it may damage the connecting pins.**

### 9.3 Connection between S461 Outputs and Customer Equipment

This section provides figures to show how outputs supported by the S461 connect with the customer equipment.

In the following figures, the **SUTO Instrument** indicates the S461.

#### Modbus/RTU output

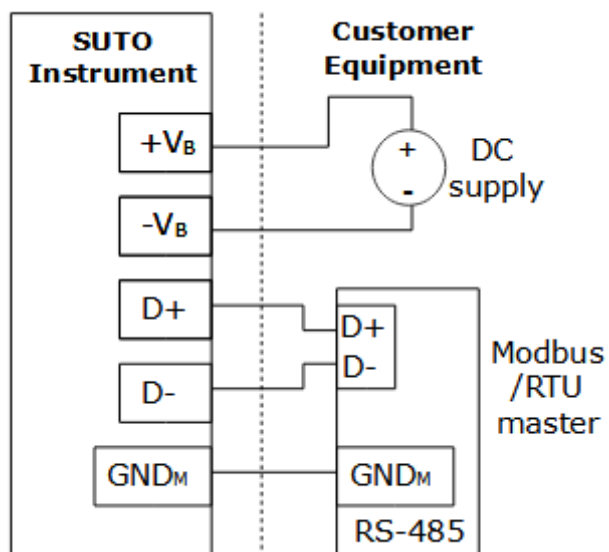

Isolated 4 ... 20 mA analog output

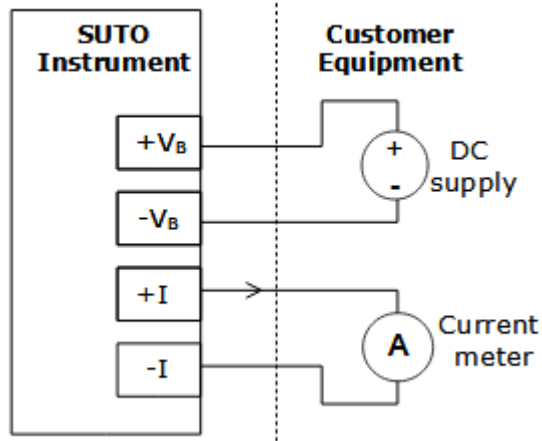

Passive pulse output

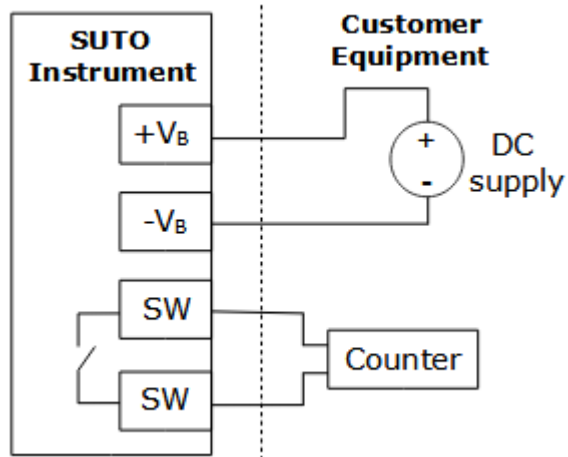

Modbus/TCP output with PoE

Class A

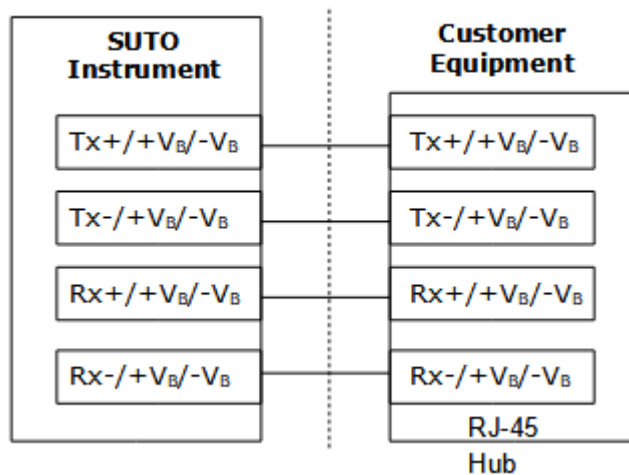

Class B

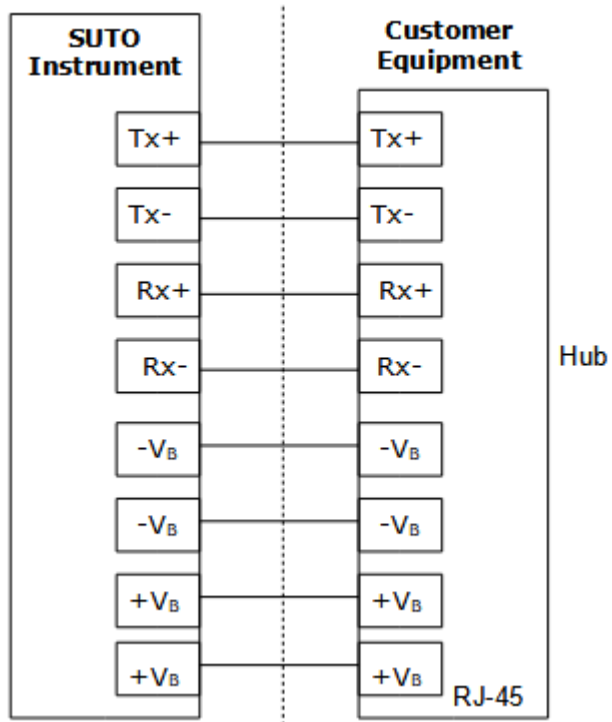

Modbus/TCP output with external power supply

Class A

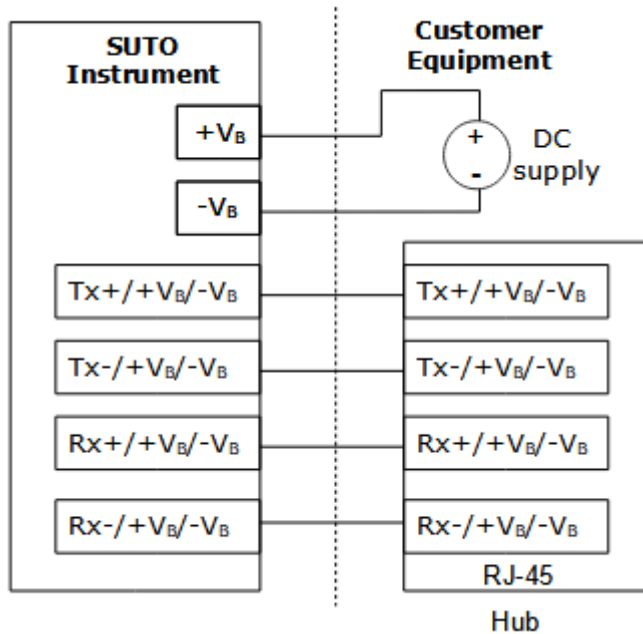

Class B

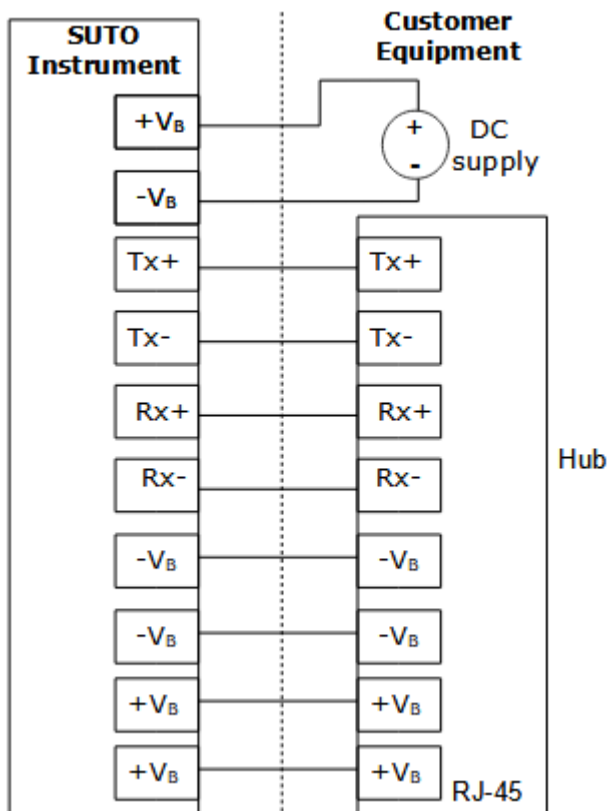

## 9.4 Set S461 by S4C-US App

After the S461 is installed, power up it. Then follow the steps in sections 9.4.3 and 9.4.4 to start the mobile App S4C-US and set the parameters of the S461.

### 9.4.1 Install S4C-US App

The S4C-US App is available for download on Apple Store, Google Play Store and the SUTO Website ([www.suto-itec.com](http://www.suto-itec.com)).

Use your mobile phone to download and install the application, same as you do for any other Apps.

### 9.4.2 Scan QR Code

To configure the S461, you must scan the QR code by using the S4C-US App to enable the configuration.

#### Preparation:

- Power on the S461.
- Obtain the QR code. The QR code can be found on the S461 main unit or the calibration certificate.

#### Steps:

1. Activate the **S4C-US** App on your mobile phone.
2. Click the **Scan QR Code** button.
3. Scan the QR code.

After scanning the QR code, the S4C-US gets the S461 information, and the signal icon changes from **Orange** to **Green**, indicating that the S461 is configurable using the S4C-US.

### 9.4.3 Basic Settings

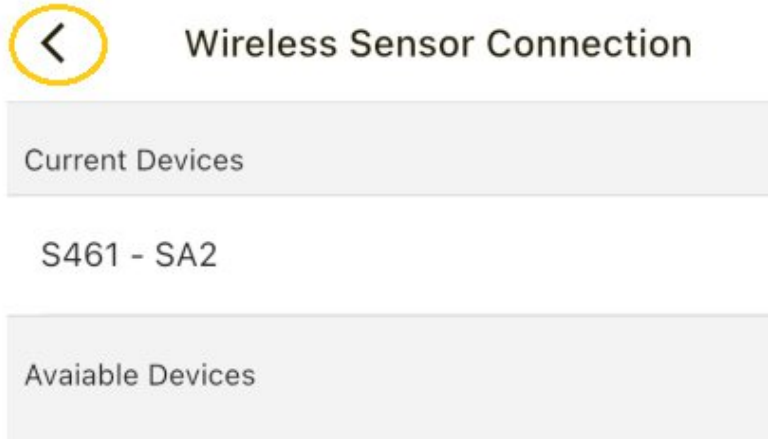
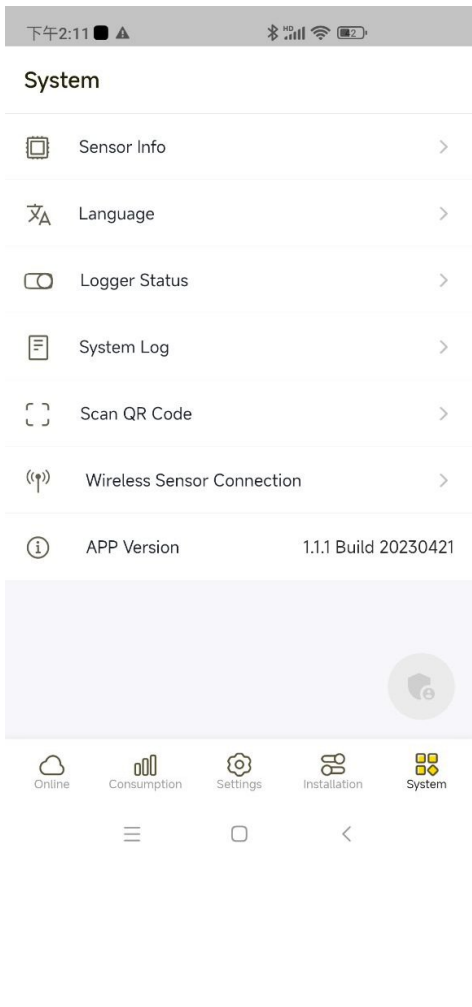
Description	App view
<p>Follow the steps below to make the wireless connection with the S461.</p> <ol style="list-style-type: none"> <li>1. Tap on <b>System &gt; Wireless Sensor Connection</b>.</li> <li>2. Press as next the search icon.</li> </ol> <p>After a few seconds all S461 nearby will be listed with it's Serial Number as identifier.</p> <ol style="list-style-type: none"> <li>3. Select the unit which you want to connect to and finally the return arrow.</li> </ol> 	

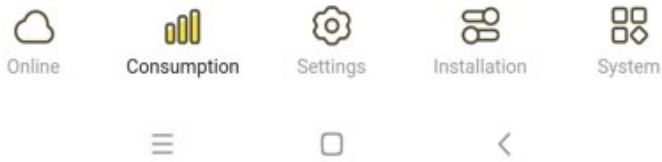
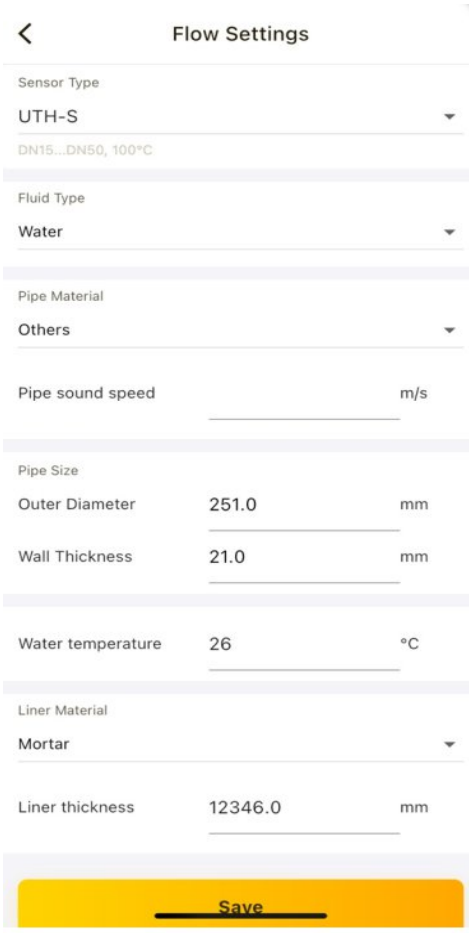
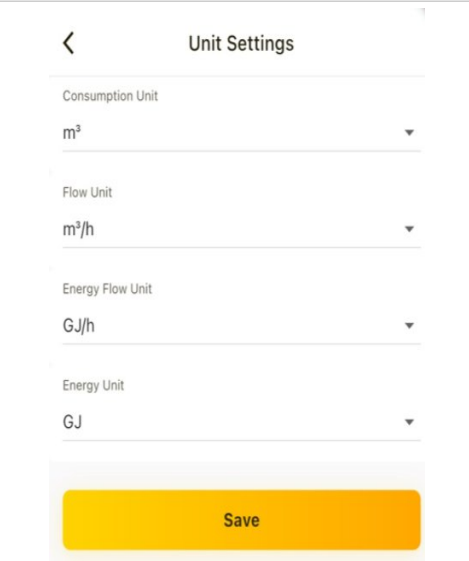
Description	App view
<p>4. Tap on the <b>Settings</b> for entering the basic settings:</p>  <p><b>Flow Settings:</b></p> <ul style="list-style-type: none"> <li>• Sensor Type: UT-S (standard sensor) or UTH-S (high temperature sensor).</li> <li>• Fluid Type: fluid type to be measured.</li> <li>• Pipe material</li> <li>• Pipe sound speed: this value depends on the pipe material. The App provides sound speeds for certain materials. If you select <b>Others</b> in <b>Pipe material</b>, see the Appendix B – Sound Speed of Pipe Material to set the value.</li> <li>• Pipe Size: outer diameter and wall thickness.</li> <li>• Water temperature: requires only a rough estimations as it has a slight effect on the transducer distance calculation.</li> <li>• Liner material</li> <li>• Liner thickness</li> </ul>	
<p>Under <b>Unit Settings</b> enter the desired physical units to be used. It can be chosen units for:</p> <ul style="list-style-type: none"> <li>• Consumption</li> <li>• Flow</li> <li>• Energy flow</li> <li>• Energy</li> </ul>	

### 9.4.4 Installation Settings

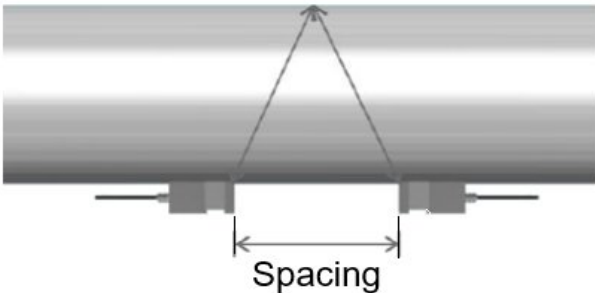
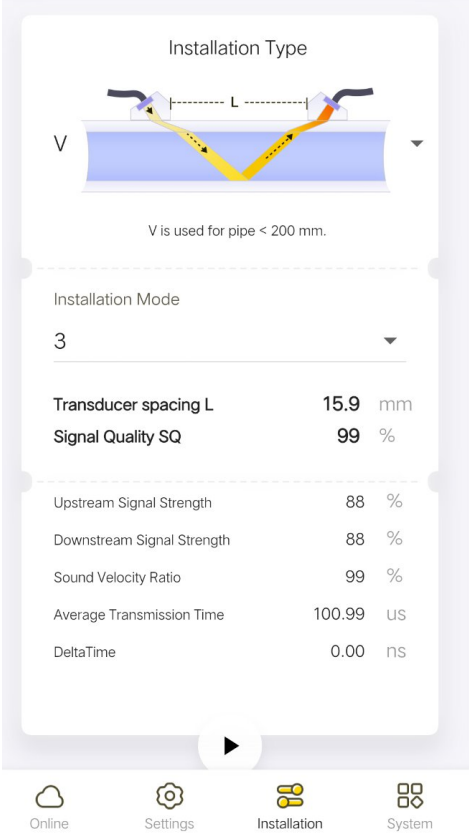
Description	App view
<p>Tab on the <b>Installation</b> to make the final settings and monitor the installation status.</p> <ol style="list-style-type: none"> <li> <p>Select <b>mounting method</b></p> <ul style="list-style-type: none"> <li>The <b>V</b>-method is the standard method for pipes DN50 to DN300.</li> <li>The <b>Z</b>-method is used for pipes DN40 and &gt;DN300.</li> </ul> </li> <li> <p>Select <b>Installation Mode</b></p> <p>The installation mode is used to compensate the influence of impurity in pipe materials.</p> <ul style="list-style-type: none"> <li>The default Mode 3 is applicable for UT-S transducers for all pipe sizes.</li> <li>The Mode 0 is applicable for UTH-S transducers for all pipe sizes.</li> <li>When the measured value is abnormal and the error is large, and other methods are ineffective, try to select the Mode 1.</li> <li>Do not consider other installation modes.</li> </ul> </li> <li> <p>Adjust <b>Transducer spacing</b></p> <p>Adjust the spacing between two transducers on the pipeline (as shown in the figure below) according to the <b>transducer spacing L</b> displayed on the App.</p>  </li> </ol>	<p>Installation</p> 

## 9.5 Transducer Installation

This section describes procedures for installing and removing of the transducers.

The two transducers must be mounted on the pipes center line. On horizontal pipes at the side (not on top!) and on vertical pipes only of the flow direction is up!

### 9.5.1 Install a Transducer

The alignment and the spacing of the transducers are critical factors for the measurement accuracy and the system performance.

Follow the steps for a proper installation:

1. Locate an optimum position where the straight pipe length is sufficient and the pipe is in a good condition. For example, a relatively new pipe with no rust and easy to operate.
2. Clean any dust and rust on the pipe surface.
3. Choose one of the two installation methods based on the pipe diameters.

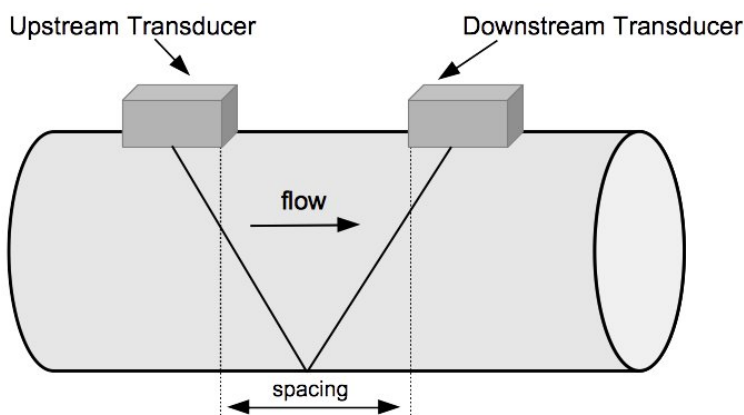

#### **V-Method:**

The transducers are mounted on the same side of the pipe and the sound crosses the pipe twice. It is commonly used for pipes DN50 to DN300.

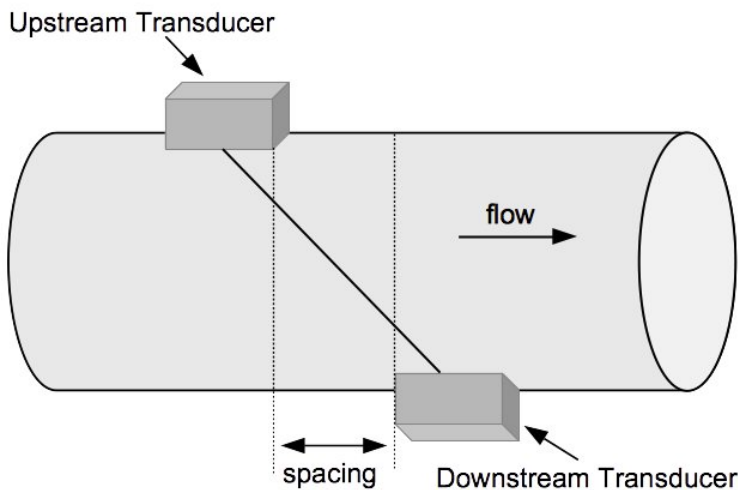
**Z-Method:**

The transducers are mounted on opposite sides of the pipe and the sound crosses the pipe once. It is commonly used for pipes DN40 and > DN300.

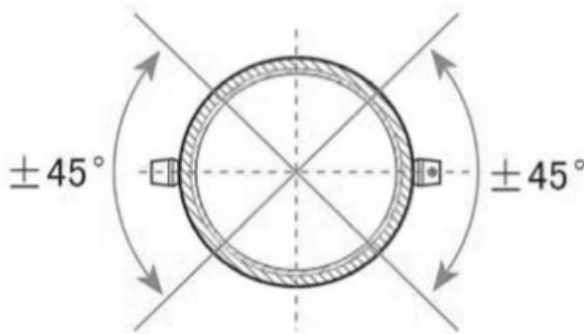

If the Z-Method is used, make sure that the transducers are mounted on a pipe within a valid angle range, as shown in the left picture.

- Grease the underside of the transducers with the coupling agent.

**ATTENTION!**

**It is recommended to use the grease-type coupling agent supplied with the transducers.**

**For outdoor applications where splash water or rain may wash-off the coupling agent, it is recommended to add some water protection to the transducers.**

- Use the worm gear clamp to attach a transducer on the pipe and leave no gap between the pipe surface and the transducer.

**ATTENTION!**

**The stretcher is under tension. Please open it carefully!**

- Install the other transducer on the pipe as described in steps 4 and 5. Make sure that the distance between the two transducers is as close as possible to the "Transducer spacing" value shown on the mobile phone App.

7. For outdoor installation it's recommended to protect the transducers from splash water as it may wash-off the coupling agent after some time.

### 9.5.2 Remove a Transducer

Remove a transducer as described below.

1. Hold the transducer.
2. Release the worm gear clamp.
3. Remove the coupling agent from the underside of the transducer.

### 9.5.3 Install a Transducer with Mounting Fixture

To simplify the installation, an optional transducer mounting fixture is provided for V-Method, the maximum pipe diameter for which is DN300. Installation steps are as follows:

1. Locate an optimum position where the straight pipe length is sufficient and the pipe is in a good condition. For example, a relatively new pipe with no rust and easy to operate.
2. Clean any dust and rust on the pipe surface.
3. Mount the transducer mounting fixture with stretcher on both side. At one end of the fixture, there is a compartment with a partition.



4. Grease the underside of the transducers with the coupling agent.
5. Place the first transducer at the end of the mounting fixture with the compartment, and rotate the knob to fix.



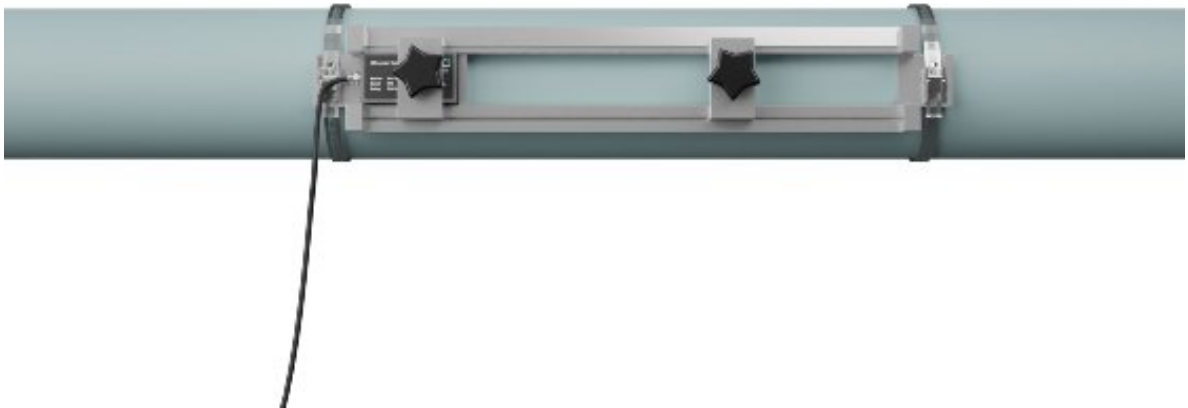

6. Put the other flow transducer from top of the fixture. Make sure that the distance between the two transducers is the "Transducer spacing" value shown on the mobile phone App. Rotate the knob to fix.

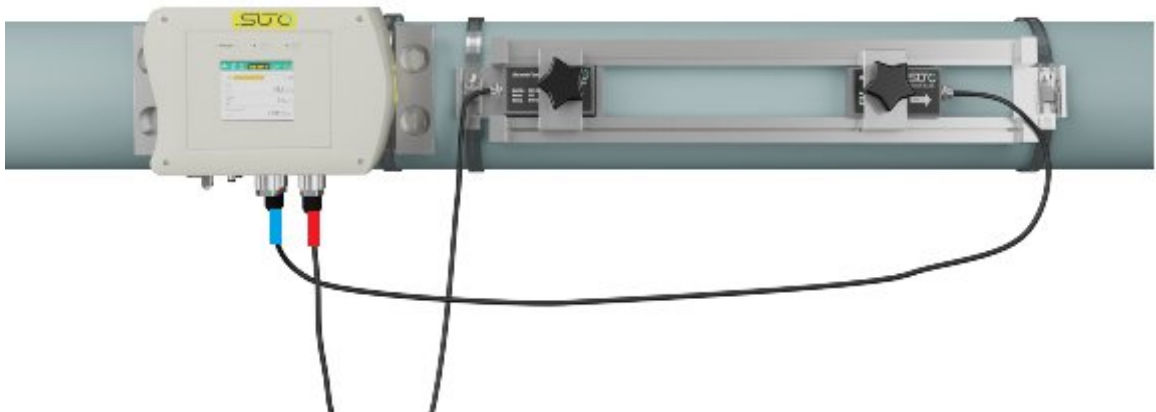

After installation and alignment, the mounting fixture must always be placed on the pipe to ensure perfect and reliable installation of the transducers.

## 9.6 Final Check

After the complete installation of the transducers an installation check should be performed to ensure that the signal strength and signal quality of the transducers are in a valid range.

In the installation dialogue of the App, you can check the parameters. Ensure that these parameters achieve the following valid values.

Parameter	Valid range	Unit
Signal Quality SQ	80.0 ... 99.0	%
Installation Status	R: Normal E: Error D: Adjusting Gain	
Upstream Signal Strength	80.0 ... 99.9	%
Downstream Signal Strength	80.0 ... 99.9	%
Sound Velocity Ratio	97 ... 103	%
Delta Time fluctuation	<20	ns

Here some recommendations if the parameters above are not within the valid ranges:

If the **Signal Strength** is not in the valid range, do the following:

- Relocate the transducers to a better position.
- Try to apply more coupling agents or clean the surface.
- Adjust position of the transducers vertically and horizontally while checking the varying signal strength and stop at the position of the highest signal strength.
- Check the transducers spacing to make sure the transducers spacing matches with the numbers shown in the mobile App.

If the **Signal Quality** is not in the valid range, do the following:

- Avoid interference from other instruments and devices such as a powerful working converter nearby. Try to relocate the flow meter to a new place where there is littler interference.
- Avoid bad sonic coupling for the transducers with the pipe. Try to apply more coupling agents or clean the surface.
- Relocate the transducers to a better position.
- Make an earth connection – there is an earth terminal at the S461.

If the **Sound Velocity Ratio** is not in the valid range, check the following to ensure:

- The parameters (pipe outside diameter, wall thickness, pipe material, liner, etc.) are entered correctly.
- The transducer mounting spacing is accordance with the value shown in the mobile App.
- The transducer is mounted at the pipe's center line on the same diameter.
- The scale is too thick or the pipe mounting is distorted in shape, etc.

The **Delta Time** is the best indication if the unit is running well. The fluctuation of the delta time should be less than 20%. If necessary check following:

- The pipe parameters are correctly entered.
- The actual spacing of the transducers is correctly placed and the same as displayed in the mobile app.
- The transducers are installed properly in the right directions.
- The mounting location is good and the pipe is not changed in shape or there is not too much fouling inside the pipes.
- Only when the pipe diameter is too small or velocity is too low can the fluctuation be wider.



The **Installation Status** can have following indications:

- **"N"** indicates that everything is normal.
- **"G"** indicates that the system is adjusting the signal gain prior to the measurement. This can be a normal situation, however when the adjustment takes too long without stopping, it can be considered as abnormal.
- **"E"** indicates that no signal is being detected. Check if the transducers are installed firmly, etc.

If an **"E"** still appears even after checking all settings and verifying the installation, please contact the manufacturer by sending screen shots from the installation screen and the flow settings.

### 9.7 LED Indicators

Three LED indicators are available on the S461 panel. Their on, off, or blinking indicates different device status.

LED	Function	LED on	LED off	LED blinking
 Power	Power supply *	S461 is powered on	S461 is powered off	S461 works abnormally **
	Wireless connection	Wireless connected	Wireless not connected	NA
	LOG	NA	***	Blinking once indicates a log is recorded.

**Notes:**

- \* Three types of power supplies are available via the following ways:
  - 24V Vb/MODBUS connector (standard)
  - POE (when the S461 supports Modbus/TCP)
  - USB port (in particular cases)

The three power supply types can be used simultaneously or in combination, and the power supply LED works normally. Connection of USB for power supply can also brightens the screen, but only for upgrading and exporting logs, not making the S461 fully functional.

- \*\* It is normal that the power supply LED blinks during a firmware upgrade.
- \*\*\* The LED being off indicates that either of the following cases occurs:
  - The log function is disabled.
  - When the log function is enabled, the LED remains off while the S461 is waiting for capturing logs.

### 9.8 Values on Display

The display on the S461 main unit can show the major measuring values, as shown below. Press the  button to view more values.

<b>S461 as a flow meter</b>	<b>S461 as an energy meter</b>
-----------------------------	--------------------------------

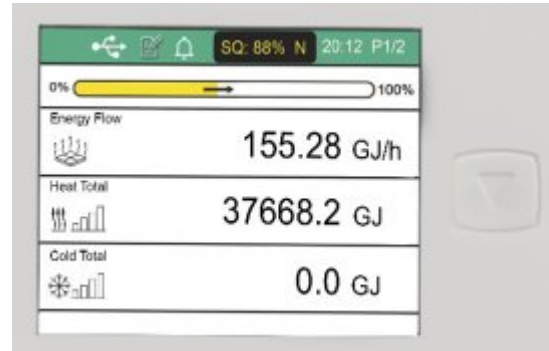
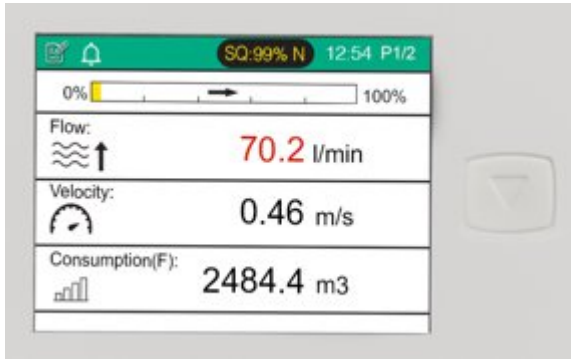

Measuring channels on the screen:

- Flow
- Velocity
- Consumption(F)
- Consumption(R)

Measuring channels on the screen:

- Energy Flow
- Heat Total
- Cold Total
- Temperature Inlet
- Temperature Outlet
- Delta T
- Flow
- Velocity
- Consumption(F)
- Consumption(R)

Some measurements have upper limits; for details, see the range column of the **Resolution and units** table in the *S461 Modbus Register Table IM*.

### 9.9 Other Issues and Recommended Actions

Symptom	Action
<p>The display shows 0.00 for the flow rate while the flow inside the pipe is not zero.</p>	<p>Use the <b>Remove Zero Calibration</b> function under the <b>Zero Calibration</b> menu on the mobile app.</p> <p>Check the <b>Cut-Off Velocity</b> setting under the Factory Settings.</p>
<p>The display shows a much higher or lower flow rate than the actual one.</p>	<p>Check if the transducer is correctly installed.</p> <p>Zero calibrate the instrument by using <b>Zero Flow Calibration</b> and make sure that the flow inside the pipe is zero.</p> <p>Use <b>Min velocity</b> and <b>Max velocity</b> settings under the <b>Factory Settings</b> menu to limit the output velocity and flow rate.</p>
<p>A measurement value reaches its upper limit.</p> <p>For example, the energy channel shows 9999999.</p>	<p>Change the channel unit to a greater unit, for example, change kJ to a greater unit like GJ. The conversion relationship among different units is listed in the <b>Resolution and units</b> table of the <i>S461 Modbus Register Table</i> IM.</p>
<p>The consumption value reaches its upper limit of 999,999.</p>	<p>1. When using a unit of measurement other than cubic meters (m<sup>3</sup>), the consumption will stop increasing once it reaches the upper limit, but the value will not reset automatically. To handle this:</p> <ul style="list-style-type: none"> <li>• Switch to a larger unit of measurement, and the consumption will continue to increase.</li> <li>• Alternatively, reset the consumption to zero using the</li> </ul>

<b>Symptom</b>	<b>Action</b>
	<p>S4C-US App, and the accumulation will start over.</p> <p>2. When using cubic meters (m<sup>3</sup>) as the unit and the upper limit is reached, the displayed value will freeze for a short period before automatically resetting to zero. The duration of the freeze depends on the flow rate.</p>

## 10 View Measurement Data

Measurement data of each channel and consumption can be viewed on the **Online** and **Consumption** menus on the S4C-US App.

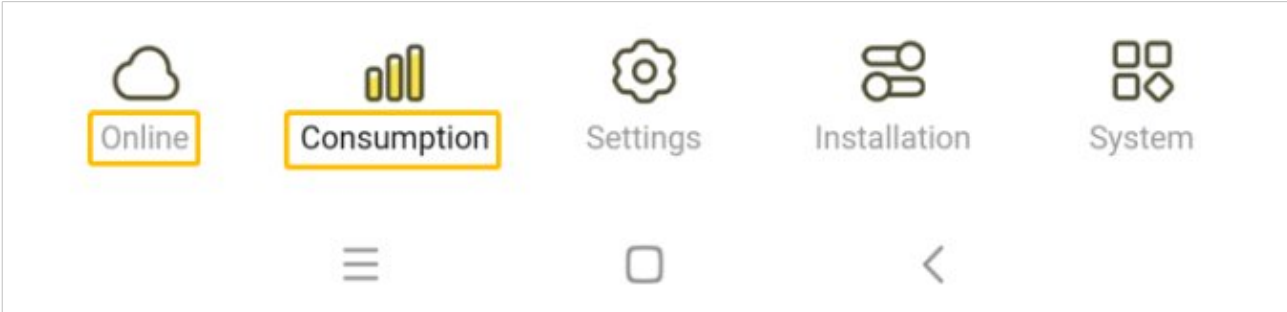

### 10.1 Online

The online page shows measurement data of each channel. The S461 flow meter and energy meter have different channels as shown below.

S461 Flow Meter

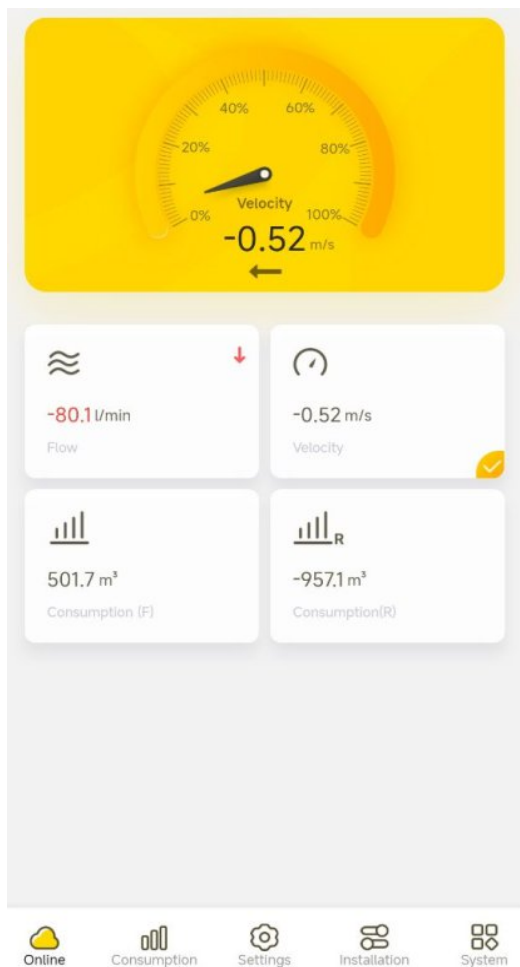

S461 Energy Meter



## 10.2 Consumption

The consumption can be viewed on a daily, weekly, or monthly basis by a bar chart (📊) or in tabular form (📄).

For the energy meter, click to select the energy or consumption channels.

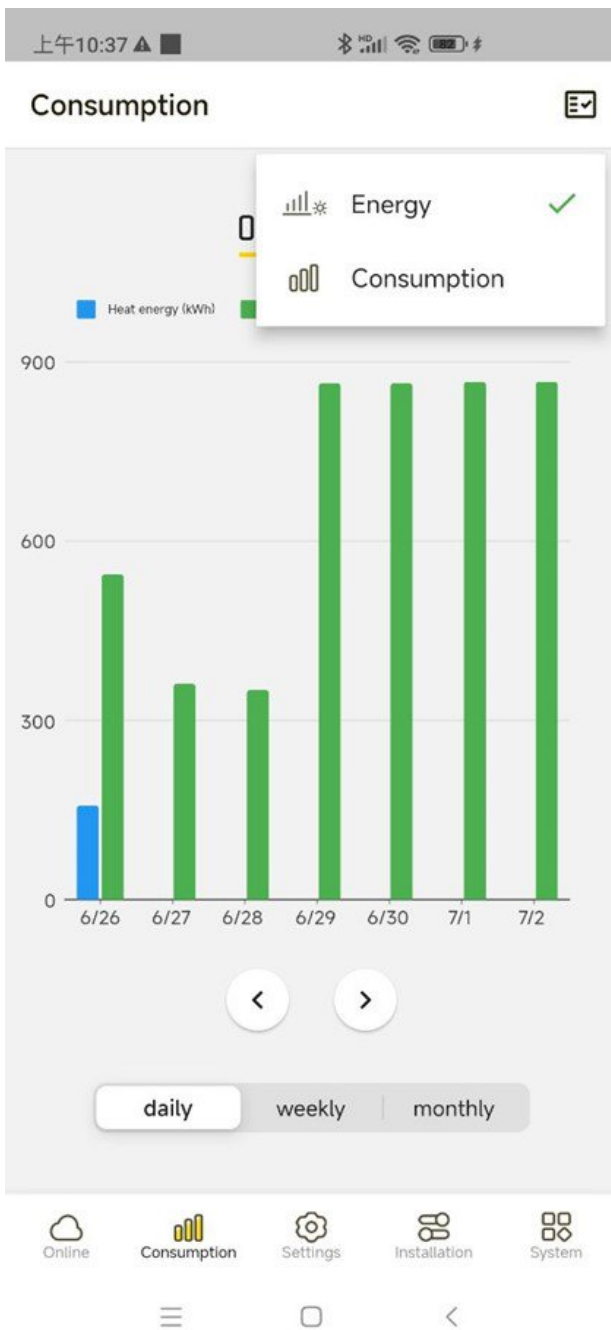

Date	Heat energy (kWh)
6/26	158.4
6/27	0.0
6/28	0.0
6/29	0.0
6/30	0.0
7/1	0.0
7/2	0.0

## 11 Other Settings

### 11.1 Factory Settings

#### 11.1.1 Fixed Delay

The fixed delay is used for fine-tuning the sound velocity ratio. The closer the sound velocity ratio is to 100%, the more accurate the measurement becomes. When adjusting the fixed delay, if the sound velocity ratio is less than 100%, enter a positive number (0 to 5) for the fixed delay; if greater than 100%, enter a negative number (-5 to 0). Once the fixed delay is set, do not change it arbitrarily.

#### 11.1.2 Cut-Off Velocity

Velocity measured below this setting will be displayed as zero. Recommended setting is 0.03 m/s.

#### 11.1.3 Bi-directional Flow

When this parameter is activated the velocity and flow rates are displayed as negative value if a reverse flow is detected. There are separate consumption counters for forward and reverse direction.

#### 11.1.4 Delta T Cut-Off

For the energy meter version if a Delta T below this setting is measured it will be displayed as zero. T indicates temperature.

#### 11.1.5 Min velocity, Max velocity

Min velocity: If the flow is unidirectional, this value is the minimum velocity and cannot be modified. If the flow is bidirectional, set this value to the maximum velocity in the reverse direction.

Max velocity: set the maximum of the output velocity.

When the measured velocity exceeds the set value, the output velocity is limited to the set value until the measured velocity is equal to or below the set value.

## 11.2 Totalizer Settings

There are 3 different totalizers in the instrument accumulating the consumption of Flow, Heat and Cold. Each of the totalizers can be reset to zero. This function requires special authorization.

## 11.3 Alarm Settings

Alarm monitoring can be activated. If the Analog/Alarm option is integrated in the instrument a relay output is activated on alarm. If not, the alarm indication is on the local display and on the mobile app in the online window to be seen.

## 11.4 Output Settings

By default the S461 comes with Modbus/RTU interface and can be additionally equipped with either Modbus/TCP or Analog / Pulse / Alarm.

### 11.4.1 Modbus/RTU Output Settings

Parameter	Description	Settings
Address	Set the device address. Each device must have a unique device address.	1 ... 247 Default: 1
Baudrate	Select a baud rate.	- 1200 - 2400 - 4800 - 9600 - <b>19200</b> (default) - 38400 - 57600 - 115200
Parity/Framing	Select the parity, framing and stop bit.	- 8,E,1 - 8,O,1 - <b>8,N,1</b> (default)

**Note:** All devices on the bus must have the same communication parameters: baud rate, parity, stop bit.

### 11.4.2 TCP/IP Output Settings

Parameter	Description	Settings
Port	The port number of TCP/IP service.	0 ... 65536 <b>502</b> (default)
DHCP	Enable or disable DHCP (Dynamic Host Configuration Protocol).	<input type="radio"/> : <b>disabled</b> (default) <input checked="" type="radio"/> : enabled
IP Address	The IP address of the device in LAN.	-
Subnet Mask	The subnet mask of LAN.	255.255.255.0 (default)
Gateway	The IP address of the gateway in LAN.	-

### 11.4.3 Analog Output Settings

Parameter	Description	Settings
Channel	Select the channel type.	- Flow - <b>Velocity</b> (default) - Heat power
Scaling type	Select the scaling type. <b>Fixed</b> : indicates the output is scaled from 0 ... 12 m/s which is equal to 0 ... max flow, and cannot be modified. <b>Variable</b> : indicates the output is scaled from -12 ... 12 m/s which can be equal to a configurable flow.	- <b>Fixed</b> (default) - Variable

### 11.4.4 Pulse Output Settings

Parameter	Description	Settings
Channel	Select the channel type.	- <b>Forward consumption</b> (default) - Reverse consumption - Heat energy
Pulse Per Unit *	Select how many units of consumption a pulse is equivalent to. Example: <b>1 pulse per 10</b> indicates that one pulse is equivalent to 10 units of consumption.	- Deactivated - <b>1 pulse per 1</b> (default) - 1 pulse per 10 - 1 pulse per 100

\* Explanations for Pulse Per Unit:

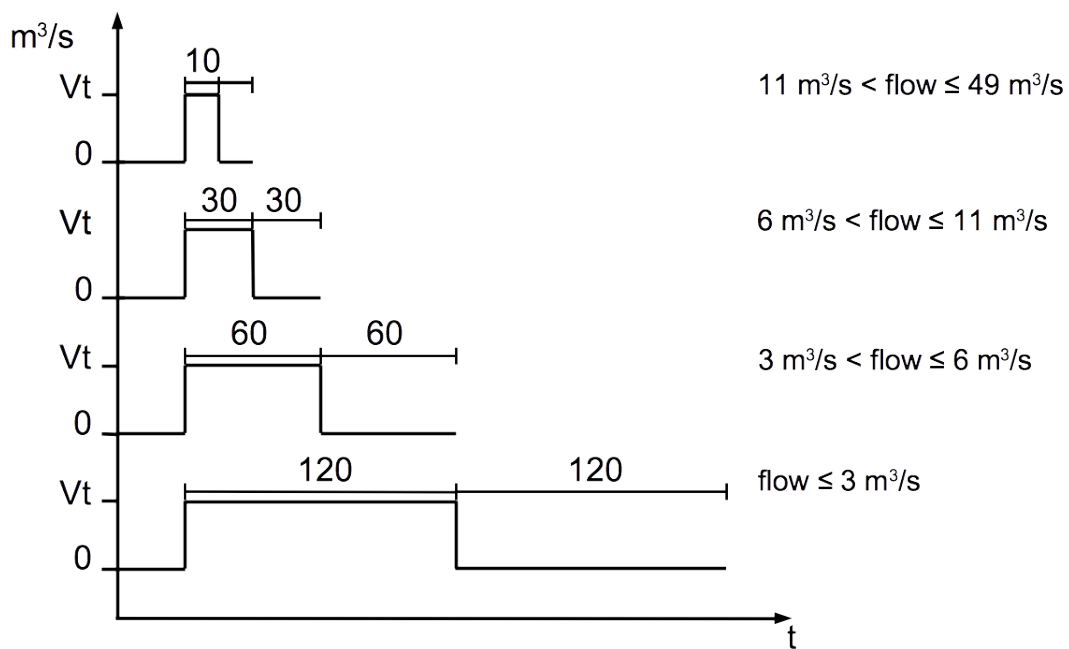
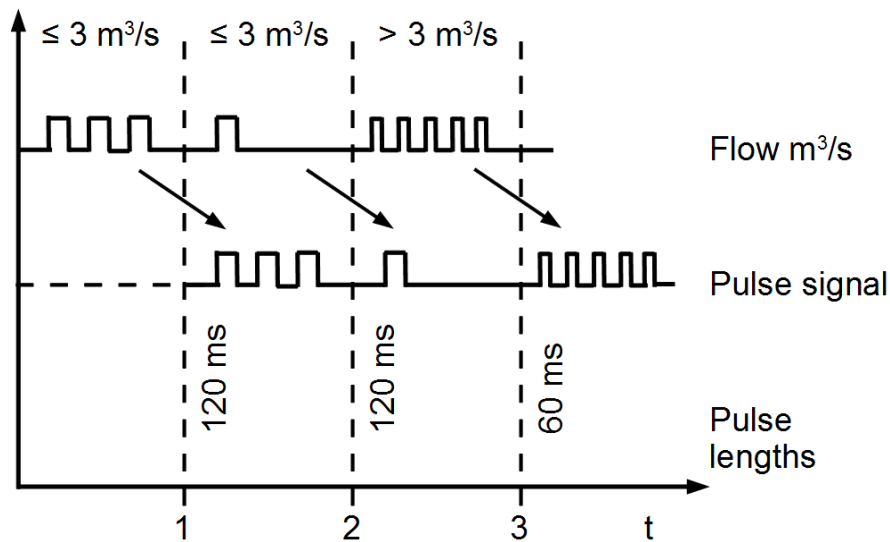

The S461 outputs one pulse per a consumption unit. This pulse output can be connected to an external pulse counter to count the total consumption. The number of m<sup>3</sup> per second are summed up and indicated after one second. Pulse length depends on the flow rate, as shown in figures below.



Volumetric flow [m <sup>3</sup> /s]	Volumetric flow [m <sup>3</sup> /h]	Pulse length [ms]	Max. pulse output per hour
≤ 3	≤ 10800	120	1080
> 3	> 10800	60	2880
> 6	> 21600	30	3960

In case that the flow rate is too high, the S461 cannot output the pulses with default settings (one pulse per consumption unit). In this case, you can set the pulse to 1 pulse per 10 consumption units or 1 pulse per 100 consumption units, using the S4C-US service app.

### 11.4.5 Alarm Output Settings

Parameter	Description	Settings
Alarm setting	Indicate if the alarm is enabled or disabled.	 : <b>disabled</b>  : enabled
Alarm	Indicate using flow or velocity to set alarm threshold.	- Flow - <b>Velocity</b> (default)
Low alarm	The threshold and hysteresis are used to activate or deactivate the alarm. When the flow or velocity is lower than the threshold, the low alarm is activated. When the flow or velocity is higher than the (threshold + hysteresis), the low alarm is deactivated.	Default threshold=0  Default hysteresis=1
High alarm	When the flow or velocity is higher than the threshold, the high alarm is activated. When the flow or velocity is lower than the (threshold - hysteresis), the high alarm is deactivated.	Default threshold=0  Default hysteresis=1

**Note:** When the alarm output is disabled, the pulse output functions. When the alarm output is enabled, the pulse output does not function.

## **11.5 Calibration**

To access the Calibration functions a special authorization is required.

Only the SUTO service people can apply for the **Calibration** authorization by contacting SUTO Service Team.

### **11.5.1 Zero Flow Calibration**

It is used to remove and to perform a zero flow calibration. When doing the zero flow calibration please ensure that there is no flow in the pipe!

### **11.5.2 T-Offset Calibration**

This function is available for the Energy Meter version. It can be used to adjust the temperature readings through an offset.

### **11.5.3 User Calibration**

This function can be used to adjust the flow meter at up to 5 calibration points in a third party flow lab.

## **11.6 Logger Settings**

Through this function the internal data logger is activated and the recording interval is set. It will always record all available measuring channels. The recordings can be read out through the mobile app or through the PC software S4A.

## 12 System Functions

### 12.1 Sensor Info

It shows details of the device such as Serial Number, calibration Date, Hardware version etc. Please make a screen shot in case of any technical inquiries.

### 12.2 Language

It is used to select the user interface language.

### 12.3 Logger Status

Shows the logger status with start and end date and number of recordings.

### 12.4 Logger Readout

Read log files at following time periods:

- **Last hour:** indicates last hour. For example, it's 11:30 now, and the **last hour** indicates 10:00:00 ~ 10:59:59.
- **Last day:** indicates the whole day before today. For example, it is April 12th today, and the **Last day** indicates 00:00:00 on April 11 ~ 23:59:59 on April 11.
- **Last week:** indicates the whole week before this week. For example, it is Wednesday, April 12th today, and the **Last week** indicates Monday, April 3, 00:00:00 ~ Sunday, April 9, 23:59:59.
- **Last month:** indicates the whole month before this month. For example, it is April 12th today, and the **Last month** indicates March 1, 00:00:00 ~ March 31, 23:59:59.
- Time period: indicates a certain time period that can be defined by the user.

Click **View Graph** on the **Logger Readout** page, then click  icon on the upper right corner to select a channel, the graph of the channel is shown.

The CSD and CSV log files can be shared through Email, chat tools, and so on, which is based on the operation system of your mobile phone.

**Note:**

- This function requires the hardware version V2.1 or above and the firmware version V2.07 or above.
- The CSD file can be viewed vis SUTO S4A or S4M software.
- If the number of recorded lines (1 line is a time stamp plus all channels) is greater than 2400 a data compression will be performed to reduce the amount of data to be transferred. This ensures a fast wireless readout.  
To obtain the complete measuring data of the logger, use the S4A software to read the S461.

**12.5 System Log**

For internal use. Take a copy and send it to SUTO customer service in case of technical inquiries.

**12.6 Wireless Sensor Connection**

It is used to make a wireless connection to S461.

**12.7 App Version**

It shows the installed version number.

## 13 Calibration

In certain installations the display will show a non-zero flow even if there is absolutely no flow. In this case, a zero point calibration is recommended. Make sure that there is zero flow in the pipe before activating this function in the sensor menu.

The instrument is calibrated ex work. The exact calibration date is printed on the certificate which is supplied together with the instrument. The accuracy of the instrument is regulated by the on site conditions, parameters like oil, high humidity or other impurities can affect the calibration and furthermore the accuracy. However it is recommended to calibrate the instrument at least once per year. The calibration is excluded from the instruments warranty. For this please contact the manufacturer.

## 14 Maintenance

To clean the flow meter and its accessories it is recommended to use moist cloth only.



### **ATTENTION!**

**Do not use isopropyl alcohol to clean the display!**

## 15 Disposal of Waste



Electronic devices are recyclable material and do not belong in the household waste.

The device, the accessories and its packing must be disposed according to your local statutory requirements. The dispose can also be carried by the manufacturer of the product. Please contact the manufacturer for details.

## 16 Appendix A – Modbus Register Table

### 16.1 Modbus Interface

The default settings of the Modbus communication interface are shown as below.

Mode	: RTU
Baud rate	: 19200
Device address	: Last two digits of the serial number
Framing / parity / stop bit	: 8, N, 1
Response timeout	: 1 second
Response delay	: 0 ms
Inter-frame spacing	: 7 char

#### Response message that the device returns to the master:

- Function code: 03

The information of the byte order is shown in the table below:

Byte Order	Sequence				Data Type
	1st	2nd	3rd	4th	
1-0-3-2	Byte 1 (MMMMMMMM*)	Byte 0 (MMMMMMMM *)	Byte 3 (SEEEEEEE)	Byte 2 (EMMMMMMM *)	FLOAT
1-0-3-2	Byte 1	Byte 0 LSB	Byte 3 MSB	Byte 2	UINT32 INT32
1-0	Byte 1 MSB	Byte 0 LSB	---	---	UINT16 INT16
1-0	Byte 1 XXX *	Byte 0 DATA	---	---	UINT8 INT8

\* S: Sign, E: Exponent, M: Mantissa, XXX: no value

---

## Explanations of MSB and LSB

---

- MSB** MSB refers to Most Significant Byte first, which follows the Big-Endian byte order.  
For example, if the main system follows the MSB first order:  
When the 4-byte floating number, in the order of Byte1-Byte0-Byte3-Byte2, is received from the slave (sensor), the master must change the byte order to Byte3-Byte2-Byte1-Byte0 for the correct display of the value.
- 
- LSB** LSB refers to Least Significant Byte first, which follows the Little-Endian byte order.  
For example, if the main system follows the LSB first order:  
When the 4-byte floating number, in the order of Byte1-Byte0-Byte3-Byte2, is received from the slave (sensor), the master must change the byte order to Byte0-Byte1-Byte2-Byte3 for the correct display of the value.
- 

**Remarks:** Modbus communication settings as well as other settings can be changed by the service App **S4C-US** or through the windows based **Service Software**.

## 16.2 Modbus Registers

The table below lists the frequently-used Modbus registers.

Addr.	Data type	Data Length	Description	Contents/ Example	R/ W
<b>Channel value</b>					
2301	Float	4-Byte	Flow	Value	R
2303	Float	4-Byte	Velocity		R
2305	Float	4-Byte	Consumption (Forward)		R
2307	Float	4-Byte	Consumption (Reverse)		R
2311	Float	4-Byte	Energy Flow (instant energy)	Energy meter only	R
2313	Float	4-Byte	Heat accumulated	Energy meter only	R
2315	Float	4-Byte	Cold accumulated	Energy meter only	R
2317	Float	4-Byte	Delta T	Energy meter only	R
2319	Float	4-Byte	Temperature inlet	Energy meter only	R
2321	Float	4-Byte	Temperature outlet	Energy meter only	R

The complete Modbus register table can be downloaded by clicking the link below:

[S461 Modbus Register Table](#)

([https://www.suto-itec.com/wp-content/uploads/2023/12/S461\\_Modbus\\_Register\\_Table\\_User\\_Version\\_EN\\_2023-1.pdf](https://www.suto-itec.com/wp-content/uploads/2023/12/S461_Modbus_Register_Table_User_Version_EN_2023-1.pdf))

or scanning the QR code below:



## 17 Appendix B – Sound Speed of Pipe Material

Pipe material	Velocity (m/sec)
Acrylic (Perspex)	2,730
Aluminum	6,320
Beryllium	12,900
Brass	4,430
Composite, graphite/epoxy	3,070
Copper	4,660
Fiberglass	2,740
Inconel®	5,820
Iron, Cast (soft)	3,500
Iron, Cast (hard)	5,600
Iron oxide (magnetite)	5,890
Lead	2,160
Lucite®	2,680
Molybdenum	6,250
Nickel, pure	5,630

Pipe material	Velocity (m/sec)
Polyamide	2,200
Nylon	2,600
Polyethylene, high density (HDPE)	2,460
Polyethylene, low density (LDPE)	2,080
Polystyrene	2,340
Polyvinylchloride (PVC)	2,395
Rubber, polybutadiene	1,610
Steel, 1020	5,890
Steel, 4340	5,850
Steel, 302 austenitic stainless	5,740
Tin	3,320
Titanium	6,100
Tungsten	5,180
Zinc	4,170
Zirconium	4,650

## 18 Appendix C – Install Insertion PT1000

The PT1000 with order number A4617 is an insertion temperature sensor.

### 18.1 Items for Installation

The items required for installation are listed in the table below. Choose either A554 6003 or A554 6004 for installation.

No.	Description
A4617	Insertion temperature sensor pair, 5 m cable, PT1000 Class B, M8 connector, -50 ... +250°C, 6 x 150 mm sensor probe, for use with the S461 energy meter only
A554 6003	Compression fitting, 6 mm, G ½" thread, Max. pressure 0.6 MPa
A554 6004	Compression fitting, 6 mm, G ½" thread, metal ring, Max. pressure 1.6 MPa
	Ball valve (To be prepared by the user)
	Installation base, weld it onto the pipe (To be prepared by the user)

### 18.2 Installation Requirements

1. Pressure in the pipe

The pipeline pressure must not exceed the maximum pressure rating of the selected compression fitting.

2. Installation location

Do not install on a vertical pipe section where water flows downward. If water flows downward, the protective tube of the temperature sensor may be broken by the water flow. Even if it is not broken, the vibration will be significant, affecting temperature measurement (typically resulting in higher measured temperature values).

3. Installation orientation

- When the flow velocity in the pipeline is high, it is recommended to install the flow meter at an angle in the direction of water flow.
- When the flow velocity is low, it can be installed vertically to the pipeline.

### 18.3 Installation Steps

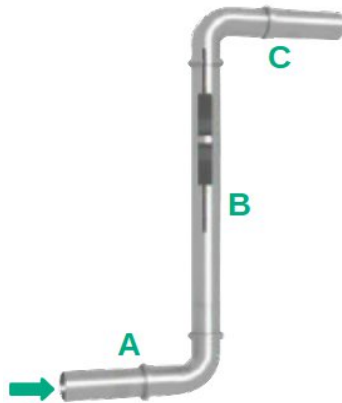

Positions A, B, and C in the diagram indicate three pipe sections. The arrow indicates the direction of flow. The PT1000 can be installed in any section—all positions provide comparable measurement results.

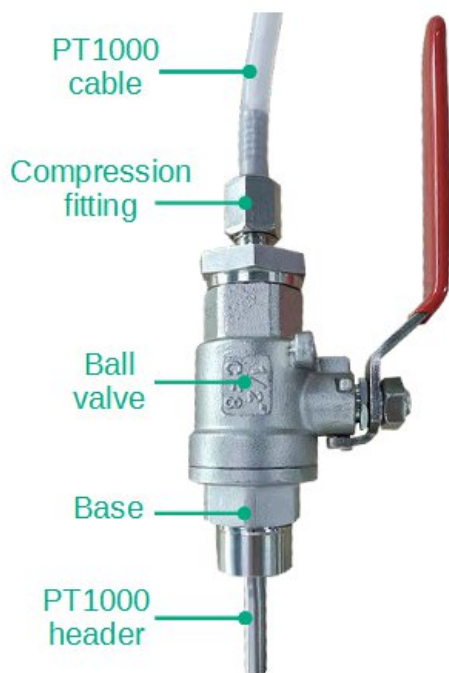

1. Weld the base.  
The base needs to be welded to the pipe in advance.
2. Install the ball valve. Then turn off the ball valve to prevent liquid from spraying out.
3. Install the compression fitting. The compression fitting must be securely connected to the ball valve.

#### 4. Install the PT1000.

- a) Ensure that the ball valve is closed.
- b) Insert the PT1000 into a small portion of the compression fitting and slightly tighten the upper part of the compression fitting (as shown in the figure), taking care not to tighten it too much! This will reduce liquid leakage during subsequent operations and allow the PT1000 to move up and down.
- c) Hold the PT1000 in one hand and turn on the ball valve with the other hand.

**Note:** At this point, liquid may flow out from the top of the compression fitting. Hold the PT1000 firmly to prevent it from being ejected when the ball valve is turn on.

---

d) Slowly insert the PT1000 into the pipe and determine the installation position of the probe.

**Note:** The PT1000 probe must not come into direct contact with the pipe wall!

e) Tighten the compression fitting to complete the installation of the PT1000.

---

---

**SUTO iTEC GmbH**

Grißheimer Weg 21  
D-79423 Heitersheim  
Germany

Tel: +49 (0) 7634 50488-00  
Email: [sales@suto-itec.com](mailto:sales@suto-itec.com)  
Website: [www.suto-itec.com](http://www.suto-itec.com)

**SUTO iTEC (ASIA) Co., Ltd.**

Room 10, 6/F, Block B, Cambridge Plaza  
188 San Wan Road, Sheung Shui, N.T.  
Hong Kong

Tel: +852 2328 9782  
Email: [sales.asia@suto-itec.com](mailto:sales.asia@suto-itec.com)  
Website: [www.suto-itec.com](http://www.suto-itec.com)

---

**SUTO iTEC Inc.**

5460 33rd St SE  
Grand Rapids, MI 49512  
USA

Tel: +1 (616) 800-7886  
Email: [sales.us@suto-itec.com](mailto:sales.us@suto-itec.com)  
Website: [www.suto-itec.com](http://www.suto-itec.com)

**SUTO iTEC (Thailand) Co., Ltd.**

91/66 Suwinthawong Rd,  
Minburi Bangkok 10510  
Thailand

Tel: +66 (0)2108 9658  
Email: [sales.th@suto-itec.com](mailto:sales.th@suto-itec.com)  
Website: [www.suto-itec.com](http://www.suto-itec.com)