

Instruction and operation manual

S 420

Thermal mass flow sensor



Dear Customer,

thank you for choosing our product.

The operating instructions must be read in full and carefully observed before starting up the device. The manufacturer cannot be held liable for any damage which occurs as a result of non-observance or non-compliance with this manual.

Should the device be tampered with in any manner other than a procedure which is described and specified in the manual, the warranty is cancelled and the manufacturer is exempt from liability.

The device is destined exclusively for the described application.

SUTO iTEC GmbH offers no guarantee for the suitability for any other purpose. SUTO iTEC GmbH is also not liable for consequential damage resulting from the delivery, capability or use of this device.

Table of contents

1. Safety instructions.....	4
2. Application.....	6
3. Features.....	7
4. Technical Data.....	8
4.1 General.....	8
4.2 Electrical Data.....	8
4.3 Output-Signals.....	9
4.4 Accuracy	9
5. Dimensional drawing.....	9
6. Installation considerations.....	11
7. Inlet and Outlet section.....	12
8. Sensor Installation	13
8.1 Removal of the flow sensor	14
8.2 Electrical connection	15
9. Sensor signal outputs.....	17
9.1 Analog output.....	17
9.2 Pulse output.....	17
9.2.1 Pulse Connection Diagram.....	19
9.3 Modbus output.....	21
10. Sensor display (option).....	22
10.1 Starting process.....	22
10.2 Error messages.....	22
10.3 Configuration using the display.....	23
11. Calibration.....	25
12. Maintenance.....	25
13. Disposal or waste.....	25
14. Warranty.....	25
Appendix.....	27

1. Safety instructions

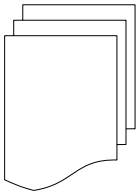

Please check if this instruction manual accords to the product type.

Please observe all notes and instructions indicated in this manual. It contains essential information which have to be observed before and during installation, operation and maintenance. Therefore this instruction manual has to be read carefully by the technician as well as by the responsible user / qualified personnel.

This instruction manual has to be available at the operation site of the flow sensor at any time. In case of any obscurities or questions, regarding this manual or the product, please contact the manufacturer.



WARNING!

Compressed air!

Any contact with quickly escaping air or bursting parts of the compressed air system can lead to serious injuries or even death!

- Do not exceed the maximum permitted pressure range (see sensors label).
- Only use pressure tight installation material.
- Avoid that persons get hit escaping air or bursting parts of the instrument.
- The system must be pressureless during maintenance work.

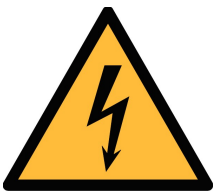

WARNING!

Voltage used for supply!

Any contact with energized parts of the product, may lead to a electrical shock which can lead to serious injuries or even death!

- Consider all regulations for electrical installations.
- The system must be disconnected from any power supply during maintenance.
- Any electrical work on system is only allowed by authorized qualified personal.

**WARNING!****Permitted operating parameters!**

Observe the permitted operating parameters, any operation exceeding this parameters can lead to malfunctions and may lead to damage on the instrument or the system.

- Do not exceed the permitted operating parameters.
- Make sure the product is operated in its permitted limitations.
- Do not exceed or undercut the permitted storage and operation temperature and pressure.
- The product should be maintained and calibrated frequently, at least annually.

General safety instructions

- It is not allowed to use the product in explosive areas.
- Please observe the national regulations before/during installation and operation.

Remarks

- It is not allowed to disassemble the product.
- Always use spanner to mount the product properly.

**ATTENTION!****Measurement values can be affected by malfunction!**

The product must be installed properly and frequently maintained, otherwise it may lead to wrong measurement values, which can lead to wrong results.

- Always observe the direction of the flow when installing the sensor. The direction is indicated on the housing.
- Do not exceed the maximum operation temperature at the sensors tip.
- Avoid condensation on the sensor element as this will affect accuracy enormously.

Storage and transportation

- Make sure that the transportation temperature of the sensor without display is between -30°C... 70°C and with display between -10°C... 60°C.
- For storage and transportation it is recommended to use the packaging which comes with the sensor.
- Please make sure that storage temperature of the sensor is between -10°C... 50°C.
- Avoid direct UV and solar radiation during storage.
- For the storage the humidity has to be <90%, no condensation.

2. Application

The S 420 is a flow sensor which is designed to measure the consumption of compressed air and gases within the permissible operating parameters. These parameters can be found in the technical data section.

The S 420 can measure the following values:

- Velocity of the compressed air or gas.
- Volume flow of the compressed air or gas.
- Total consumption of the compressed air or gas.

The default factory settings are: Velocity in m/s, Volume flow in m³/h and Total Consumption in m³. Other units can be programmed by the optional display or the service kit.

The S 420 flow sensor is not developed to be used in explosive areas. For the use in explosive areas please contact the manufacturer.

The S 420 flow sensor is mainly used in compressed air systems in industrial environment.

3. Features

- Inline type sensor for high accuracy in small tube diameters.
- Thermal mass flow measurement, virtually independent of pressure and temperature changes.
- IP65 casing provides robust protection in the industrial environment.
- Very fast response time.
- Particularly suitable for measuring process gases such as N₂, Ar, O₂, CO₂ etc.
- Optional display directly on the sensor, showing velocity, volume flow and consumption.
- Modbus interface (optional).

4. Technical Data

4.1 General

CE	
Parameters	Standard unit flow: m ³ /h other units: m ³ /min, l/min, l/s, cfm, kg/h, kg/min, kg/s Standard unit velocity: m/s
Reference conditions	ISO1217 20°C 1000 mbar (Air) DIN1343 0°C 1013,25 mbar (all other gases)
Principle of measurement	Thermal mass flow
Sensor	Glass coated resistive sensor
Measuring medium	Air, N ₂ , O ₂ , Ar, N ₂ O, CO ₂ , other gases on request
Operating temperature	-30... 50°C -10... 50°C with display (optional)
Humidity of the meas. medium	< 90%, no condensation
Operating pressure	Up to 1.6 MPa Up to 4.0 MPa (optional)
Housing material	PC + ABS
Material of the probe tube, sensor head and the screwing	Stainless steel 1.4404
Protection class	IP65
Dimensions	See dimensional drawing on the next page
Display (optional)	128 x 64 pixel, with backlight
Tube diameter	1/4" to 3"
Screwing thread	R thread or flange
Weight	0.35 kg (instrument only, doesn't include the measuring section)

4.2 Electrical Data

Power supply	12... 30 VDC, 100 mA
--------------	----------------------

4.3 Output-Signals

Analog output	Signal: 4... 20 mA Scaling: 0 to max. volume flow / velocity Accuracy: 0.06 mA
Pulse output	1 pulse per m ³ , amplitude: + Vb, 10 mA (active signal) 1 pulse per m ³ , isolated switch, max. 30 VDC, 10 mA (pulse length: 30...120 ms, depends on consumption rate)
Modbus output	See chapter 9.3

4.4 Accuracy

Accuracy	± 2% of measured value + (± 0.3% full scale) Temperature drift: 0.05%/K Pressure drift: 0.5%/MPa
Stated accuracy at	Ambient/process temperature 23°C ± 3°C Ambient/process humidity <90% Process pressure 0.6 MPa

5. Dimensional drawing

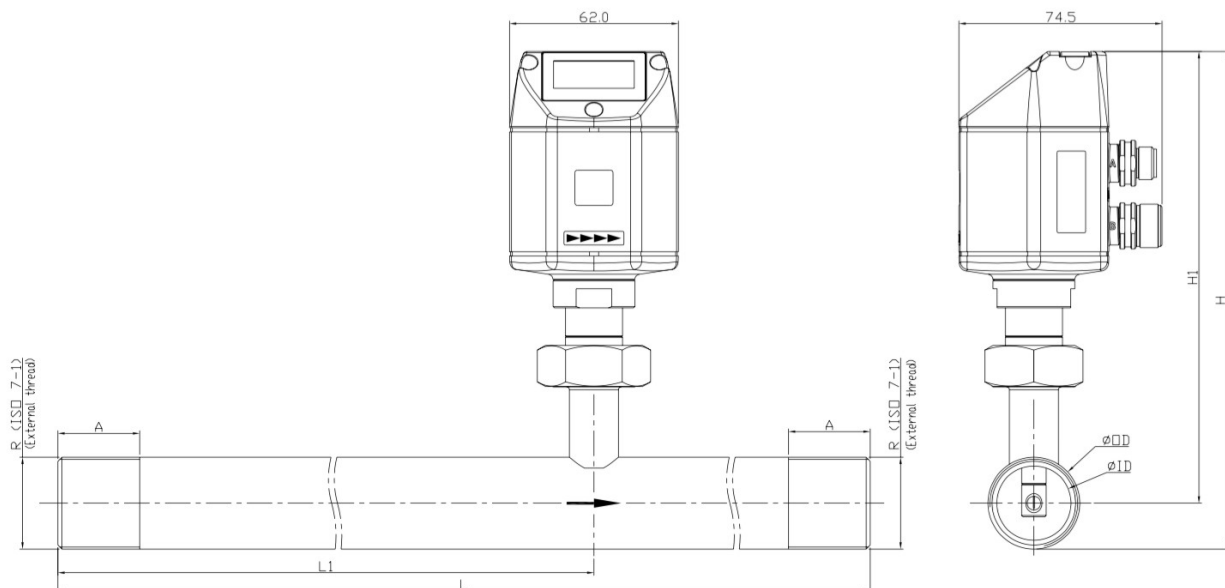

Pipe nominal size	L total length [mm]	L1 inlet length [mm]	H total height [mm]	H1 from pipe center to casing top [mm]	R External thread	A Thread length [mm]
1/2"/(DN15)	300	210	176.4	165.7	R 1/2"	20
3/4"/(DN20)	475	275	179.2	165.7	R 3/4"	20
1"/(DN25)	475	275	182.6	165.7	R 1"	25
1 1/4"/(DN32)	475	275	186,9	165,7	R 1 1/4"	25
1 1/2"/(DN40)	475	275	189.9	165.7	R 1 1/2"	25
2"/(DN50)	475	275	195.9	165.7	R 2"	30

6. Installation considerations

In order to maintain the accuracy stated in the technical data, the sensor must be installed inline and fitted to tubes with the same diameter. Please make sure it exists unhindered flow characteristics. Unhindered flow characteristics are achieved if the section in front of the sensor (inlet) and behind the sensor (outlet) is sufficiently long, absolutely straight and free of obstructions such as edges, seams, curves etc..

Please consider that enough space exists at your site for a adequate installation as described in this manual.



ATTENTION!

Wrong measurement is possible, if the sensor is not installed correctly.

- Careful attention must be paid to the design of the inlet and outlet section. Obstructions can cause counter-flow turbulence as well as turbulence in the direction of the flow.
- The sensor is for indoor use only! At an outdoor installation, the sensor must be protected from solar radiation and rain.
- It is strongly recommend not to install S 420 permanently in wet environment as it exists usually right after a compressor outlet.

7. Inlet and Outlet section

The S 420 with tube diameters from DN8 - DN25 already has the required inlet and outlet sections.

For diameters from DN32 - DN65, the S 420 has a shortened inlet section and requires additional straight sections at the inlet and outlet. The additional length for the particular diameters are listed in the table below.

Flow obstructions before the measurement section	Additional length for DN32 [mm]		Additional length for DN40 [mm]		Additional length for DN50 [mm]		Additional length for DN65 [mm]	
	inlet	outlet	inlet	outlet	inlet	outlet	inlet	outlet
Slight curve (bend <90°C)	175	-	227.8	9.5	362.2	65.5	551.8	144.5
Reduction (Tube narrows towards measurement section)	265	-	353.5	9.5	521.5	65.5	758.5	144.5
Expansion (Tube expands towards measurement section)	265	-	353.5	9.5	521.5	65.5	758.5	144.5
90°C bend or T piece	265	-	353.5	9.5	521.5	65.5	758.5	144.5
2 x 90°C bends on one level	445	-	563	9.5	787	65.5	1103	144.5
2 x 90°C bends 3 dimensional change of direction	985	-	1191.5	9.5	1583.5	65.5	2136.5	144.5
Shut-off valve	1345	-	1610.5	9.5	2114.5	65.5	2825.5	144.5

8. Sensor Installation

Before installing the sensor, please make sure that all components listed below are included in your package.

Qty	Description	Item No.
1	Sensor	S695 4200
1	Sealing ring	No P/N
2	M12 plug	C219 0059
1	Instruction manual	No P/N
1	Calibration certificate	No P/N
1	Measuring section	A1300 ... A1303 (R thread) A1321 ... A1323 (Flange, EN-1092-1) A1341 ... A1343 (Flange, ANSI 16.5)

The S 420 is always shipped with mounted measurement section.

Please make sure that the sensor is installed correctly to the flow direction in the tube. For this observe the flow direction indicated on the housing, it must match the flow direction of the compressed air or gas. The gas flows from the inlet (long pipe section) to the outlet (short pipe section) like illustrated in the picture below.

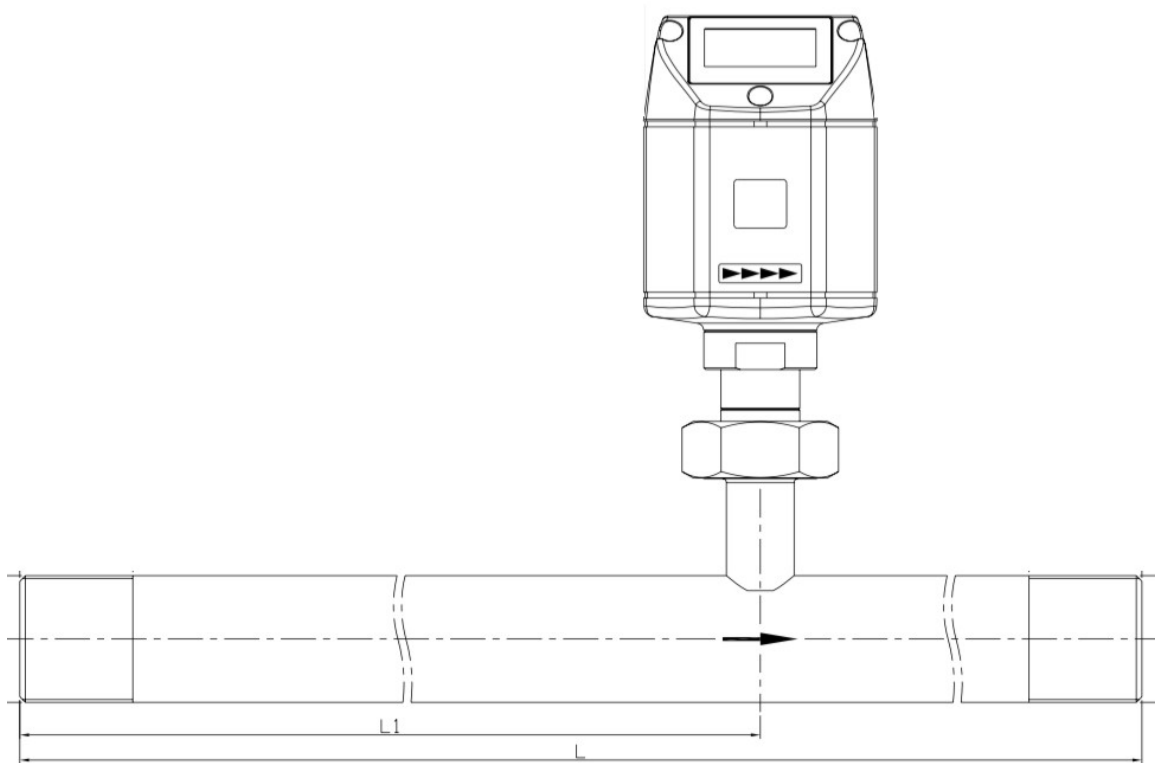

8.1 Removal of the flow sensor

The following steps explain the procedure of an appropriate removal of the sensor.



ATTENTION!

Only remove the sensor if the system is in a pressurless condition.



1. Hold the flow sensor.
2. Release the terminal nut at the connection thread.
3. Pull out the shaft slowly.
4. The measuring section can be closed with the optional closing cap, so the system can be operated normal during maintenance.



Re-installation after maintenance:

- The re-installation of the measurement device is simple as the sensor unit fits into the pipe section only in one position.
- Please make sure that the o-ring is inserted.
- Close the terminal nut tightly to mount the sensor correctly.

8.2 Electrical connection

The flow sensor is equipped with two connector plugs "A" and "B". The cables are connected to the sensor through the M12 connectors.

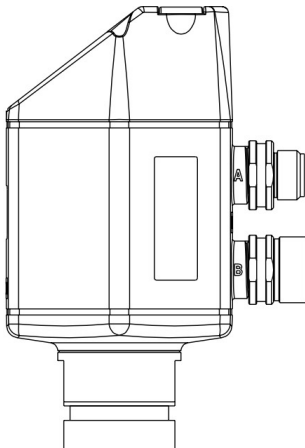

Connector plug A

Connector plug B

Connection pins connector plug M12

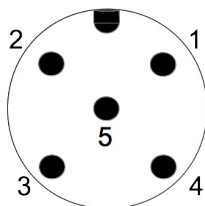

Connection pins
(view from the clamping side)

Pin assignment connector plug M12

		Pin 1	Pin 2	Pin 3	Pin 4	Pin 5
Analog and pulse	Connector plug A	SDI	$-V_B$	$+V_B$	+I 4...20 mA	+P pulse
	Connector plug B	SEL	$-V_B$	DIR	SW	SW
Modbus	Connector plug A	SDI	$-V_B$	$+V_B$	+I 4...20 mA	DIR
	Connector plug B	SEL	$-V_B$	$+V_B$	D+	D-
	Wire colour	brown	white	blue	black	grey

Legend to pin assignment

- SDI: Digital signal (internal use)
- VB: Negative supply voltage
- +VB: Positive supply voltage
- +I: Positive 4...20 mA signal
- +P: Pulse output
- SEL: Internal signal
- SW: Isolated pulse switch input/output
- DIR: Flow direction input
- D+ Modbus data +
- D- Modbus data -



ATTENTION!

Do not screw the M12 plug using force. Otherwise, it may damage the connecting pins.

9. Sensor signal outputs

9.1 Analog output

The sensor has an analogue output range of 4...20 mA. This output can be scaled to match a desired measuring range. The scaling depending on the inner diameter. Please refer to the appendix at the end of the manual. For other ranges, please contact the manufacturer.

9.2 Pulse output

The sensor will send out one pulse per consumption unit. This pulse output can be connected to an external pulse counter to count the total consumption. The number of m³ per second are summed up and indicated after one second. Pulse length depends on consumption rate.

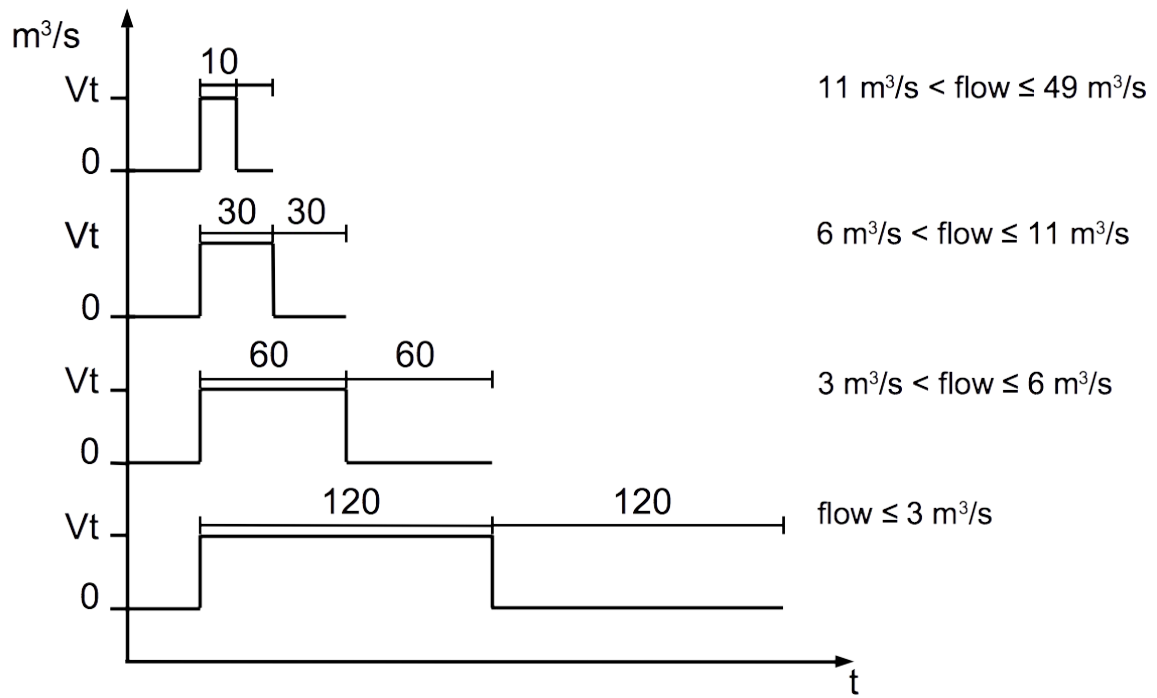
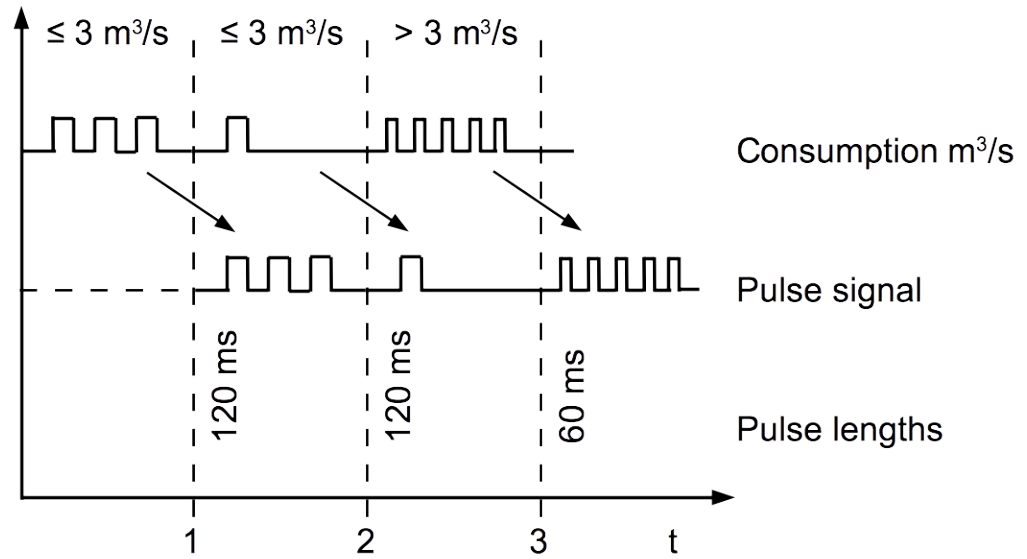

In case the flow rate is too high the S 420 can not output the pulses with default settings (one pulse per consumption unit). For this the pulse can be set by our service software or a connected display to 1 pulse per 10 consumption units or 1 pulse per 100 consumption units. For example, if set to 1 pulse per 10 m³, the sensor will send one pulse each 10 m³.

Example:

Volume flow [m ³ /h]	Pulse length [ms]	Max. consumption [m ³]
≤ 10800	120	10800
> 10800	60	28800
> 28800	30	57600

9.2.1 Pulse Connection Diagram

Using the Pulse Output P+ (Connector A Pin 5)

Variant 1:

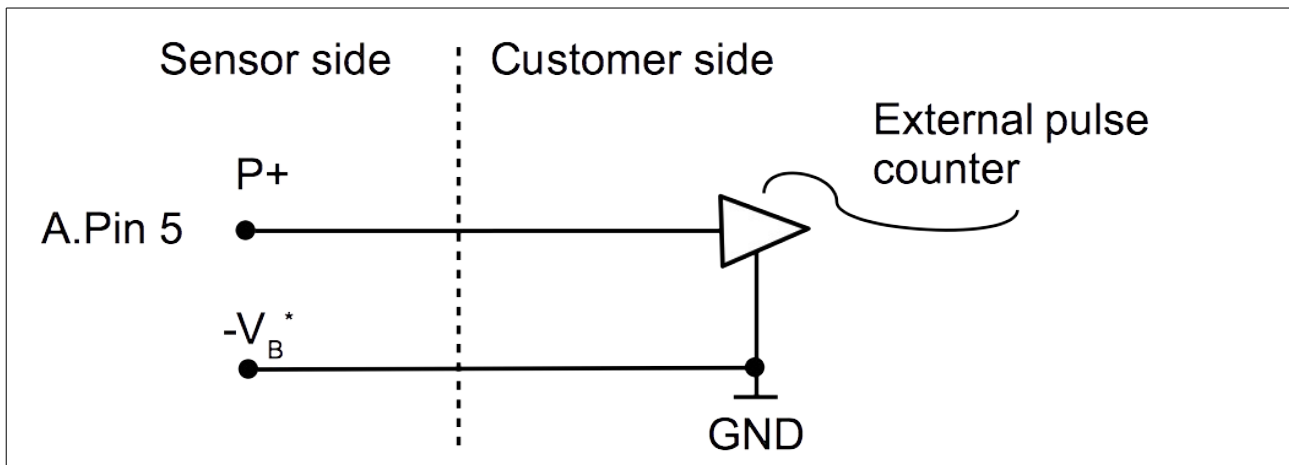

Variant 2:

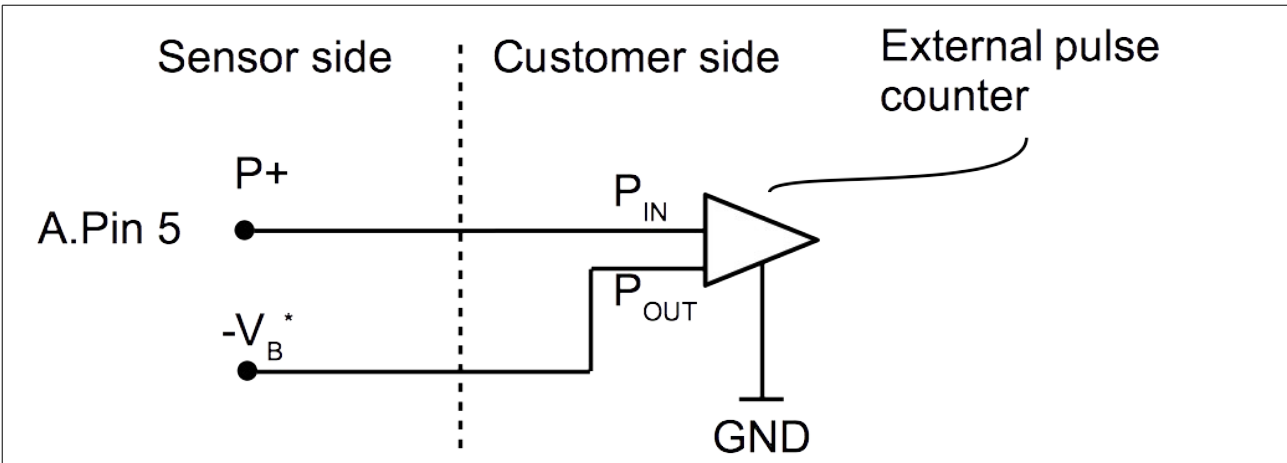

*GND of the external pulse counter must be connected to -V_B of the sensor.

Using the isolated pulse switch (Connector B Pin 4 and 5)

Variant 1:

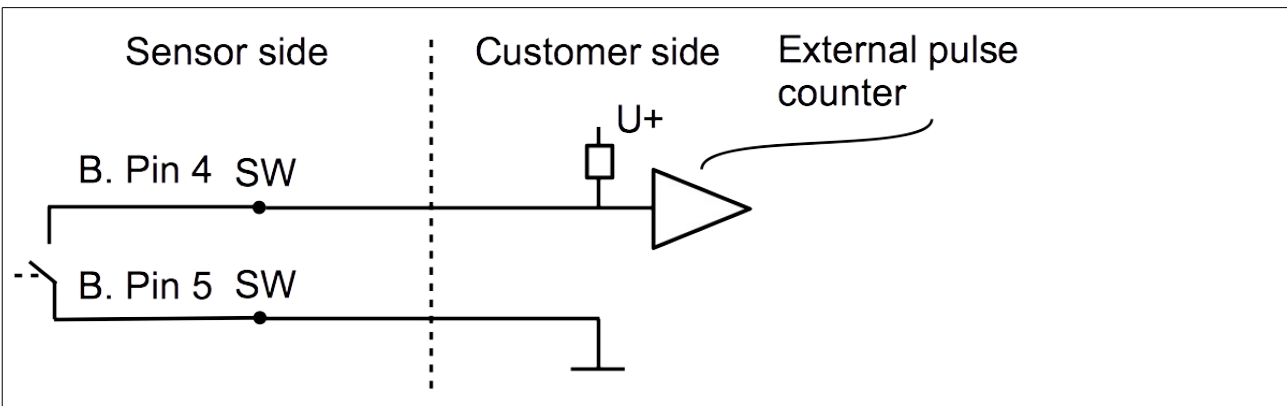

Variant 2:

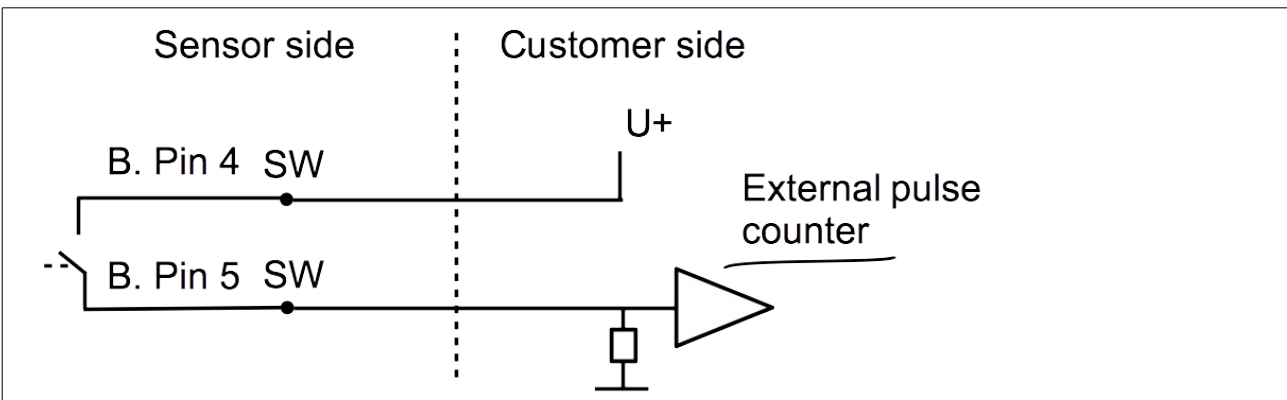

9.3 Modbus output

Mode : RTU
 Baud rate : 19200
 Device address : 1
 Framing / parity / stop bit : 8, N, 1
 Response time : 1 second
 Response delay : 0 ms
 Inter-frame spacing : 7 char

Remarks

- Modbus communication settings can be changed by the service software.

Index	Channel description	Unit	Resolution	Format	Length	Modbus address
1	Velocity	m/s	0.1	FLOAT	4 Byte	4
2	Flow	m ³ /h	0.1	FLOAT	4 Byte	6
3	Consumption	m ³	1	UNIT32	4 Byte	8

Remark

- all numbers are in little-endian format.
- Function code: 03.
- Different units have different resolutions.

10. Sensor display (option)

With the Sensor display it is possible to show the value of the velocity, the flow and the consumption. Moreover it shows error messages and it is possible to change the configuration setting of the sensor.

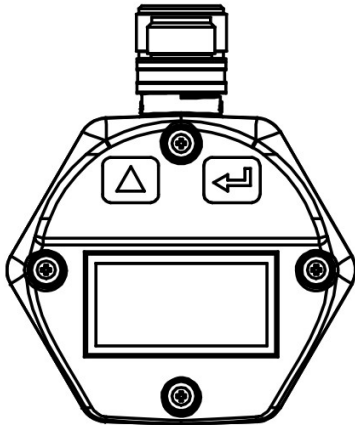

“Enter key” = 

“Up key” = 

10.1 Starting process

After power up, the display starts automatically with a initialisation procedure. During the next eight seconds the display will show the current software version and starts the connection to the sensor. Now the display goes to the standard mode, showing the online values, velocity, flow and consumption, alternately.

10.2 Error messages

Error:
Auto transmission!

It will show this message if “Auto transmission” function of the sensor was enabled. For this case please contact a technician of the manufacturer.

Error:
Communication fail!

As soon as the communication fails, the instrument will show this message. Please restart the power supply in most of the cases this will fix the problem. If the problems still exists please contact a technician of the manufacturer.

Error:
Sensor unmatched!

If the sensor and the display settings are not matching, the instrument will show this message. Please contact a technician of the manufacturer.

10.3 Configuration using the display

The S 420 is usually configured ex factory according to the ordered customer settings.

In case of settings have to be changed, please observe the following steps.

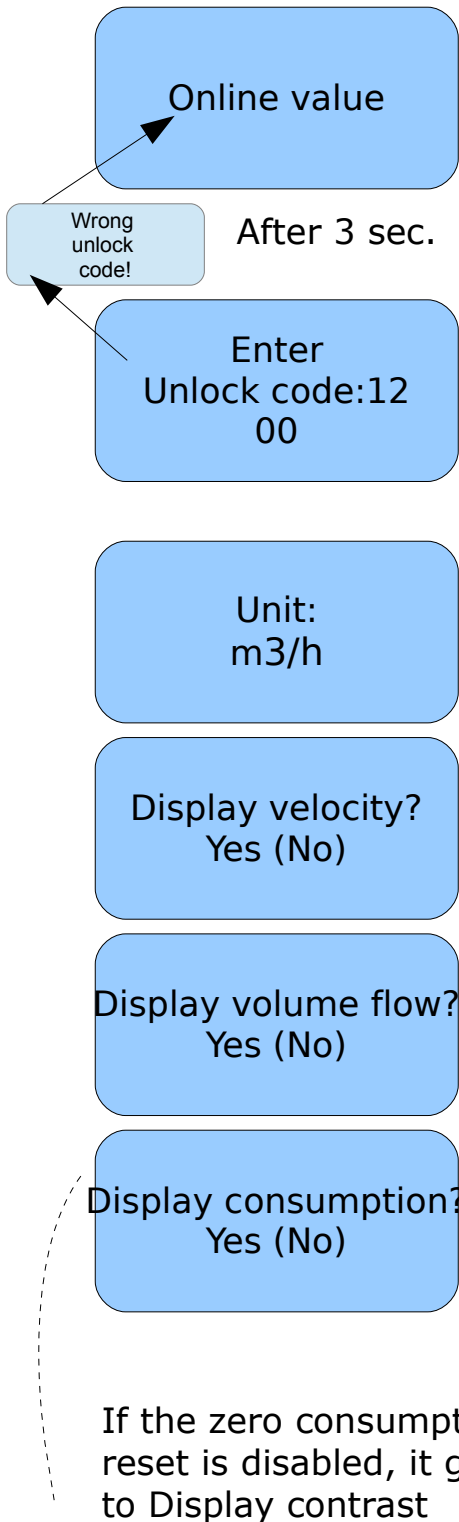

1. At first keep the enter key ($\frac{\Delta}{2}$) pressed for three seconds. Then the S 420 will ask to enter the unlock key.

2. Enter the unlock code "12". Selected digit will be flashing. To modify the digit press up key (Δ). Press enter key ($\frac{\Delta}{2}$) to confirm, shift to the next digit or go to the next page.

4. Set the desired unit of flow. To modify the unit press up key (Δ). Press enter key ($\frac{\Delta}{2}$) to confirm and go to the next page.

5. Adjust to display the velocity. Press up key (Δ) to select "Yes" or "No". Press enter key ($\frac{\Delta}{2}$) to confirm and go to the next page.

6. Adjust to display the volume flow. Press up key (Δ) to select "Yes" or "No". Press enter key ($\frac{\Delta}{2}$) to confirm and go to the next page.

7. Adjust to display the consumption. Press up key (Δ) to select "Yes" or "No". Press enter key ($\frac{\Delta}{2}$) to confirm and go to the next page. If the consumption reset is disabled, it goes directly to display contrast.

directly.

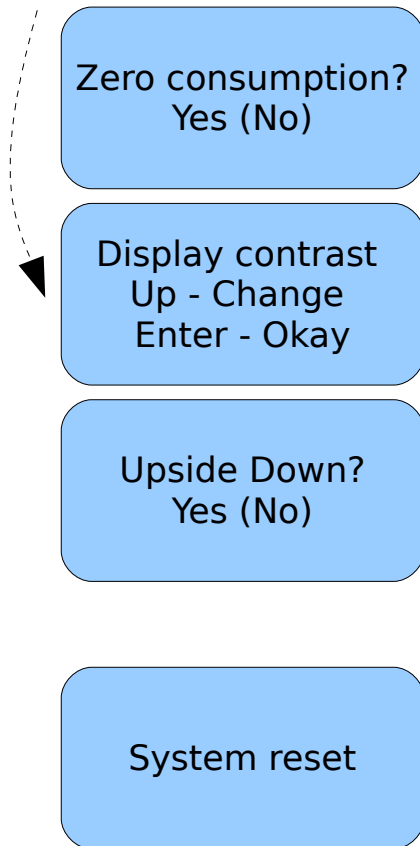

8. Reset the consumption to zero. Press up key (Δ) to select "Yes" or "No". Press enter key ($\frac{\Delta}{\Sigma}$) to confirm and go to the next page.

9. Adjust the display contrast. Press up key (Δ) to change the contrast. Press enter key ($\frac{\Delta}{\Sigma}$) to confirm and go to the next page.

10. Set the display orientation. Press up key (Δ) to select "Yes" for upside down or "No" for normal view. Press enter key ($\frac{\Delta}{\Sigma}$) to confirm. The settings will be saved automatically.

11. Online value will be shown in three seconds automatically.

Notes:

- To abort the entry process keep the enter key pressed for three seconds.
- Online value will be shown automatically if there is no key pressed for more than 20 seconds.

11. Calibration

The sensor is calibrated ex work. The exact calibration date is printed on the certificate which is supplied together with the sensor. The accuracy of the sensor is regulated by the on site conditions, parameters like oil, high humidity or other impurities can affect the calibration and furthermore the accuracy. However we recommend to calibrate the instrument at least once per year. The calibration is excluded from the instruments warranty. For this please contact the manufacturer.

12. Maintenance

To clean the sensor it is recommended to use distilled water or isopropyl alcohol only.



ATTENTION!

Do not touch the surface of the sensor plate.

Avoid mechanical impact on the sensor (e.g with a sponge or a brush).

If the contamination can not be removed the sensor has to be inspected and maintained by the manufacturer.

13. Disposal or waste

Electronic devices are recyclable material and do not belong in the household waste.

The sensor, the accessories and its packings must be disposed according to your local statutory requirements. The dispose can also be carried by the manufacturer of the product, for this please contact the manufacturer.

14. Warranty

SUTO iTEC GmbH provides a warranty for this product of 24 months covering the material and workmanship under the stated operating conditions from the date of delivery. Please report any findings immediately and within the warranty time. If faults occurring during the warranty time SUTO iTEC GmbH will repair or replace the defective unit, without charge for labour and material costs but there is a charge for other service such as transport and packing costs.

Excluded from this warranty is:

- Damage caused by:
 - Improper use and non-adherence to the instruction manual.
 - Use of unsuitable accessories.
 - External influences (e.g. damage caused by vibration, damage during transportation, excess heat or moisture).

The warranty is cancelled:

- If the user opens the measurement instrument without a direct request written in this instruction manual.
- If repairs or modifications are undertaken by third parties or unauthorised persons.
- If the serial number has been changed, damaged or removed.

Other claims, especially those for damage occurring outside the instrument are not included unless responsibility is legally binding.

Warranty repairs do not extend the period of warranty.



ATTENTION!

Batteries have a reduced warranty time of 12 month.

Appendix

Scaling table analogue output:

Medium: Air at ISO 1217; 20°C; 1000 mbar

Tube			Flow							
inch	nominal Diameter	mm	m ³ /h	m ³ /min	l/min	l/s	cfm	kg/h	kg/min	kg/s
1/4"	DN 8	8.80	5.4	0.09	90.2	1.50	3.2	6.4	0.11	0.00
1/2"	DN 15	16.10	90.0	1.50	1500.2	25.00	53.0	106.9	1.78	0.03
3/4"	DN 20	21.70	170.0	2.83	2833.4	47.22	100.1	201.9	3.37	0.06
1"	DN 25	27.30	290.0	4.83	4833.4	80.56	170.7	344.5	5.74	0.10
1 1/4"	DN 32	36.00	480.1	8.00	8000.9	133.35	282.5	570.2	9.50	0.16
1 1/2"	DN 40	41.90	552.8	9.21	9212.7	153.54	325.3	656.6	10.94	0.18
2"	DN 50	53.10	900.0	15.00	15000.1	250.00	529.7	1069.0	17.82	0.30
2 1/2"	DN 65	68.90	1026.5	17.11	17108.6	285.14	604.2	1219.3	20.32	0.34
3"	DN 80	80.90	1423.8	23.73	23729.9	395.50	838.0	1691.1	28.19	0.47

Medium: Other gases at DIN 1343; 0°C; 1013,25 mbar

Tube			N2		CO2		O2	
inch	nominal Diameter	mm	m ³ /h	cfm	m ³ /h	cfm	m ³ /h	cfm
1/4"	DN 8	8.8	5.23	3.08	5.42	3.19	5.61	3.30
1/2"	DN 15	16.1	87.04	51.23	90.12	53.04	93.32	54.93
3/4"	DN 20	21.7	164.39	96.76	170.21	100.18	176.25	103.74
1"	DN 25	27.3	280.43	165.06	290.36	170.90	300.66	176.96
1 1/4"	DN 32	36	464.20	273.22	480.66	282.90	497.69	292.93
1 1/2"	DN 40	41.9	534.52	314.61	553.43	325.74	573.10	337.31
2"	DN 50	53.1	870.29	512.24	901.11	530.37	933.09	549.19
2 1/2"	DN 65	68.9	992.63	584.24	1027.73	604.90	1064.27	626.41
3"	DN 80	80.9	1376.80	810.35	1425.48	839.01	1476.17	868.84

Tube			Nat. Gas		Ar		He	
inch	nominal Diameter	mm	m ³ /h	cfm	m ³ /h	cfm	m ³ /h	cfm
1/4"	DN 8	8.8	3.48	2.05	9.52	5.60	6.30	3.71
1/2"	DN 15	16.1	57.92	34.09	158.35	93.20	25.57	15.05
3/4"	DN 20	21.7	109.39	64.39	299.07	176.03	49.99	29.42
1"	DN 25	27.3	186.61	109.84	510.19	300.28	82.84	48.76
1 1/4"	DN 32	36	308.92	181.82	844.53	497.07	149.39	87.93
1 1/2"	DN 40	41.9	355.70	209.36	972.44	572.35	205.72	121.08
2"	DN 50	53.1	579.18	340.89	1583.35	931.92	336.62	198.13
2 1/2"	DN 65	68.9	660.53	388.78	1805.87	1062.89	575.82	338.92
3"	DN 80	80.9	916.17	539.24	2504.77	1474.25	798.68	470.08

SUTO iTEC GmbH

Werkstr. 2
79426 Buggingen
Germany

Tel: +49 (0) 7631 936889-0

Fax: +49 (0) 7631 936889-19

Email: sales@suto-itec.com

Website: <http://www.suto-itec.com>

SUTO iTEC Co., Ltd.

Room 10, 6/F, Block B, Cambridge Plaza
188 San Wan Road, Sheung Shui, N.T.
Hong Kong

Tel: +852 2328 9782

Fax: +852 2671 3863

Email: sales@suto-itec.asia

Website: <http://www.suto-itec.com>