

Instruction and Operation Manual

S421

Thermal Mass Flow Meter (Inline)



Dear Customer,

Thank you for choosing our product.

Please read this manual in full and carefully observe the operating instructions before starting up the device. The manufacturer cannot be held liable for any damage which occurs as a result of non-observance or non-compliance with this manual.

Should the device be tampered with in any manner other than a procedure which is described and specified in the manual, the warranty is void and the manufacturer is exempt from liability.

The device is designed exclusively for the described application.

SUTO offers no guarantee for suitability for any other purpose. SUTO is also not liable for consequential damage resulting from the delivery, capability, or use of this device.

Revision: 2026-1



Last modifications: May, 2026

Table of Contents

1 Safety Instructions.....	5
2 Registered Trademarks.....	7
3 RF Exposure Information and Statement.....	8
4 Application.....	9
5 Features.....	9
6 Technical Data.....	10
6.1 General.....	10
6.2 Electrical Data.....	11
6.3 Output-Signals.....	11
6.4 Accuracy	11
6.5 Volumetric Flow Ranges.....	12
7 Dimensional Drawing.....	13
8 Determine the Installation Point.....	16
8.1 Add the Required Inlet and Outlet Sections.....	16
9 Installation	22
9.1 Install the Flow Meter.....	22
9.2 Remove the Flow Meter.....	23
9.3 Electrical Connection	24
9.3.1 M12 Connector Types.....	24
9.3.2 Ethernet Connection.....	26
10 Signal Outputs.....	28
10.1 Analog Output.....	28
10.2 Pulse Output.....	28
10.2.1 Pulse Connection Diagrams (A1410).....	30
10.2.2 Pulse Connection Diagrams (A1413).....	30
10.3 Modbus Interface.....	32
10.3.1 Modbus Information.....	32
10.3.2 Connect Modbus/RTU Devices to a Master.....	34
10.4 Connection between S421 Outputs and Customer Equipment. .	38
11 Configuration.....	42
11.1 Service App S4C-FS.....	42
11.2 Device Display (Optional).....	43
11.2.1 Start-up.....	44
11.2.2 Operations.....	45
11.3 Perform Zero Flow Calibration	46
11.3.1 On S4C-FS App.....	46
11.3.2 On Flow Meter Display.....	47
11.3.3 Menu Map.....	48
12 Calibration.....	50
13 Maintenance.....	50

14 Disposal of Waste.....	50
15 Appendix - Flow Conditioner.....	51
15.1 Dimension.....	51
15.2 Installation.....	52
15.3 Ordering Information.....	53

1 Safety Instructions

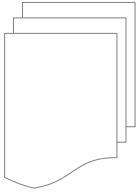

Please check if this instruction manual matches the product type.

Please observe all notes and instructions indicated in this manual. It contains essential information which must be observed before and during installation, operation, and maintenance. Therefore this instruction manual must be read carefully by the technician as well as by the responsible user / qualified personnel.

This instruction manual must be available at the operation site of the flow meter at any time. In case of any obscurities or questions, regarding this manual or the product, please contact the manufacturer.

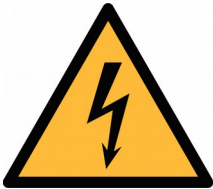

WARNING!

Compressed air!

Any contact with quickly escaping air or bursting parts of the compressed air system can lead to serious injuries or even death!

- Do not exceed the maximum permitted pressure range (see devices label).
- Only use pressure-tight installation material.
- Avoid that persons get hit by escaping air or bursting parts of the instrument.
- The system must be pressureless during maintenance work.

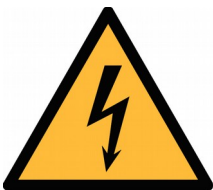

WARNING!

Voltage used for supply!

Any contact with energized parts of the product might lead to an electrical shock which can lead to serious injuries or even death!

- Consider all regulations for electrical installations.
- The system must be disconnected from any power supply during maintenance.
- Any electrical work on the system is only allowed by authorized qualified personal.

**ATTENTION!****Permitted operating parameters!**

Observe the permitted operating parameters. Any operation exceeding these parameters can lead to malfunctions and might lead to damage on the instrument or the system.

- Do not exceed the permitted operating parameters.
- Make sure the product is operated in its permitted limitations.
- Do not exceed or undercut the permitted storage and operating temperature and pressure.
- The product should be maintained and calibrated frequently, at least annually.

General safety instructions

- It is not allowed to use the product in explosive areas.
- Please observe the national regulations before/during installation and operation.

Remarks

- It is not allowed to disassemble the product.
- Always use a spanner to mount the product properly.

**ATTENTION!****Measurement values can be affected by malfunction!**

The product must be installed properly and frequently maintained. Otherwise it might lead to wrong measurement values and wrong results.

- Always observe the direction of the flow when installing the device. The direction is indicated on the housing.
- Do not exceed the maximum operating temperature at the sensor tip.
- Avoid condensation on the sensor element as this will affect accuracy enormously.

Storage and transportation

- Make sure that the transportation temperature of the device without the display is between -30 ... +70°C and with the display between -10 ... +60°C.
- For storage and transportation, it is recommended to use the packaging which comes with the device.
- Please make sure that the storage temperature of the device is between -10 ... +50°C.
- Avoid direct UV and solar radiation during storage.
- For the storage, the humidity must be <90% with no condensation.

2 Registered Trademarks

Trademark	Trademark owner
SUTO®	SUTO iTEC
MODBUS®	Modbus Organization, Hopkinton, USA
Android™, Google Play	Google LLC

3 RF Exposure Information and Statement

This equipment complies with FCC RF radiation exposure limits set forth for an uncontrolled environment. This equipment should be installed and operated with a minimum distance of 20 cm between the radiator and your body.

This device complies with part 15 of the FCC rules. Operation is subject to the following two conditions: (1) this device might not cause harmful interference, and (2) this device must accept any interference received, including interference that might cause undesired operation.

Remark: The manufacturer is not responsible for any radio or TV interference caused by unauthorized modifications to this equipment. Such modifications could void the user's authority to operate the equipment.

Remark: This equipment has been tested and found to comply with the limits for a Class B digital device, pursuant to part 15 of the FCC Rules. These limits are designed to provide reasonable protection against harmful interference in a residential installation. This equipment generates uses and can radiate radio frequency energy and, if not installed and used in accordance with the instructions, might cause harmful interference to radio communications. However, there is no guarantee that interference will not occur in a particular installation. If this equipment does cause harmful interference to radio or television reception, which can be determined by turning the equipment off and on, the user is encouraged to try to correct the interference by one or more of the following measures:

- Reorient or relocate the receiving antenna.
- Increase the separation between the equipment and receiver.
- Connect the equipment into an outlet on a circuit different from that to which the receiver is connected.
- Consult the dealer or an experienced radio/TV technician for help.
- This device and its antenna(s) must not be co-located or operating in conjunction with any other antenna or transmitter.

4 Application

The S421 is the inline-type flow meter that is designed to measure the consumption of compressed air and gases within the permissible operating parameters. (See chapter [6 Technical Data](#) on the next page.)

The S421 can measure the following values:

- Volume flow of the compressed air or gas (default unit: m³/h)
- Total consumption of the compressed air or gas (default unit: m³)

Other units can be configured by using the S4C-FS service app or the optional device display.

The S421 flow meter is mainly used in compressed air systems in industrial environment, and is not developed to be used in explosive areas. For the use in explosive areas, please contact the manufacturer.

5 Features

- Inline type flow meter for high accuracy in small tube diameters
- Thermal mass flow measurement, virtually independent of pressure and temperature changes
- IP65 casing for robust protection in the industrial environment.
- Very fast response time
- Particularly suitable for measuring process gases such as Ar, O₂, CO₂ etc
- Optional display, showing velocity, volume flow, and consumption
- Various signal output options, such as analog and pulse, Modbus/RTU, or Modbus/TCP
- Optional Power over Ethernet (PoE) for the Modbus TCP output
- Two gas calibrations (optional)

6 Technical Data

6.1 General

FCC ID: 2ASK2-SUTO-001	
Parameters	Standard unit (flow): m^3/h Other units (flow): m^3/min , l/min , l/s , cfm , kg/h , kg/min , kg/s Units (Consumption): m^3 , ft^3 , kg
Reference conditions	ISO1217 20°C 1000 hPa (Standard-Unit) DIN1343 0°C 1013.25 hPa (Norm-Unit)
Principle of measurement	Thermal mass flow
Sensor	Glass-coated resistive sensor
Measuring medium	Air, gas (non-corrosive gas)
Measuring range	See table in section 6.5
Operating temperature	-30 ... +140°C fluid temperature -30 ... +70°C casing -10 ... +50°C display (optional)
Humidity of the measured medium	< 90%, no condensation
Operating pressure	0 ... 1.6 Mpa(g), optional: 4.0 MPa(g)
Housing material	PC + ABS
Material of the shaft device head (welded parts)	Stainless steel 1.4404 (SUS 316L)
Protection class	IP65
Dimensions	See dimensional drawing on page 13
Display (optional)	2.4" color graphics display with keypad
Tube diameter	DN15 ... DN80
Weight	S421 without measuring section: 0.6 kg
	S421 + DN15 measuring section (Thread): 1.0 kg
	S421 + DN20 measuring section (Thread): 1.4 kg
	S421 + DN25 measuring section (Thread): 1.7 kg
	S421 + DN32 measuring section (Thread): 2.0 kg
	S421 + DN40 measuring section (Thread): 2.2 kg
	S421 + DN50 measuring section (Thread): 2.9 kg
	S421 + DN65 measuring section (Thread): 3.5 kg

	S421 + DN80 measuring section (Thread): 4.2 kg
	S421 + DN15 measuring section (Flange): 2.4 kg
	S421 + DN20 measuring section (Flange): 3.4 kg
	S421 + DN25 measuring section (Flange): 4.2 kg
	S421 + DN32 measuring section (Flange): 5.6 kg
	S421 + DN40 measuring section (Flange): 7.5 kg
	S421 + DN50 measuring section (Flange): 8.0 kg
	S421 + DN65 measuring section (Flange): 10.3 kg
	S421 + DN80 measuring section (Flange): 13.3 kg

6.2 Electrical Data

Power supply	15 ... 30 VDC, 200 mA 44 ... 57 VDC, 120 mA (PoE)
--------------	--

6.3 Output-Signals

Analogue output	Signal: 4 ... 20 mA, isolated Scaling: 0 to max flow Max load: 250R
Pulse output	1 pulse per consumption unit, isolated switch, max. 30 VDC, 200 mA pulse length: 10 ... 120 ms, depends on flow rate
Modbus output	See section 10.3 Modbus Interface.

6.4 Accuracy

Accuracy*	$\pm(1.5\% \text{ of reading} + 0.3\% \text{ F.S.})$ Optional high accuracy: $\pm(1\% \text{ of reading} + 0.3\% \text{ F.S.})$ Temperature drift: $< 0.05\%/K$
Stated accuracy at	Ambient/process temperature $23^{\circ}\text{C} \pm 3^{\circ}\text{C}$ Ambient/process humidity $< 90\%$ Process pressure at 0.6 MPa(g)
Repeatability	$\pm 0.25\%$ of reading
*Specified accuracy is valid only within the minimum and maximum flow rates that are indicated in section 6.5 .	

Note: The total consumption value is saved to the permanent memory every 5 minutes. If within the 5 minutes the device is powered off, it will restore the last consumption which was saved in the last cycle.

6.5 Volumetric Flow Ranges

Inch	DN	Flow range (m ³ /h)	Inch	DN	Flow range (m ³ /h)
1/2"	DN15	0.5 ... 90	1 1/2"	DN40	3 ... 700
3/4"	DN20	0.9 ... 170	2"	DN50	4 ... 1,000
1"	DN25	1.5 ... 290	2 1/2"	DN65	6 ... 1,500
1 1/4"	DN32	2 ... 500	3"	DN80	8 ... 2,500

Remarks: Measuring ranges are stated under following conditions:

- Standard flow in air
- Reference pressure: 1000 hPa
- Reference Temperature: +20°C

To calculate flow ranges based on pipe sizes and reference conditions in your site, SUTO offers the "Flow Range Calculator" tool for free. The tool can be used online from <http://www.suto-itec.com> by clicking **Support > Flow Range Calculator**.

SENSOR SELECTION

Sensor Type
S421

Measuring section
DN15

Measuring range
Standard

Pipe inner diameter
16.1

Profile
0.671

CALCULATOR OUTPUTS

Max. flow *	90	Sm ³ /h
Min. flow	0.4	Sm ³ /h
Max. velocity	183.0	Sm/s
Min. velocity	0.0	m/s

Note: Due to manufacturing tolerances in the measuring sections, the actual inner diameter may vary slightly. Consequently, the maximum flow range of each delivered flow meter can differ by up to ±1.5% from the calculated value. This variation is purely dimensional and does not affect the instrument's specified accuracy.

7 Dimensional Drawing

Thread type

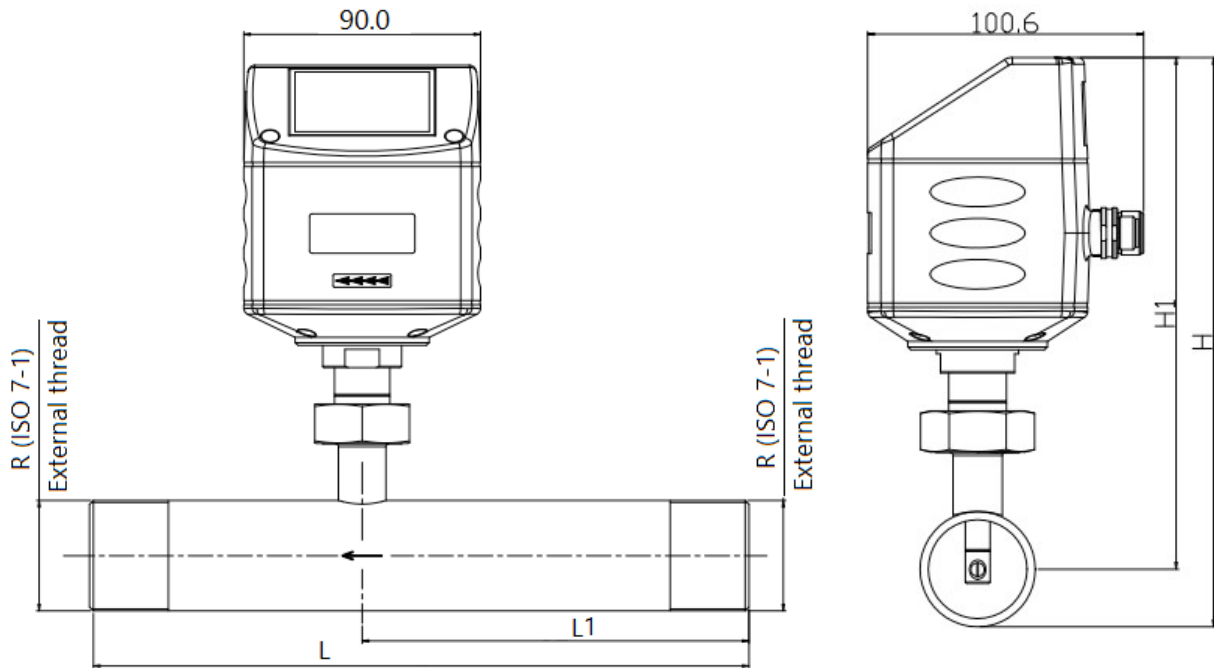

Type	Pipe nominal size inch(DN)	L total length [mm]	L1 inlet length [mm]	H total height [mm]	H1 from pipe center to casing top [mm]	R External thread
S421-1/2"	1/2"/(DN15)	300	210	197.4	186.7	R 1/2"
S421-3/4"	3/4"/(DN20)	475	275	200.2	186.7	R 3/4"
S421-1"	1"/(DN25)	475	275	203.6	186.7	R 1"
S421-1 1/4"	1 1/4"/(DN32)	475	275	207.9	186.7	R 1 1/4"
S421-1 1/2"	1 1/2"/(DN40)	475	275	210.9	186.7	R 1 1/2"
S421-2"	2"/(DN50)	475	275	216.9	186.7	R 2"
S421-2 1/2"	2.5"/(DN65)	475	275	232.7	194.6	R 2 1/2"
S421-3"	3"/(DN80)	475	275	245.5	201.0	R 3"

Flange type

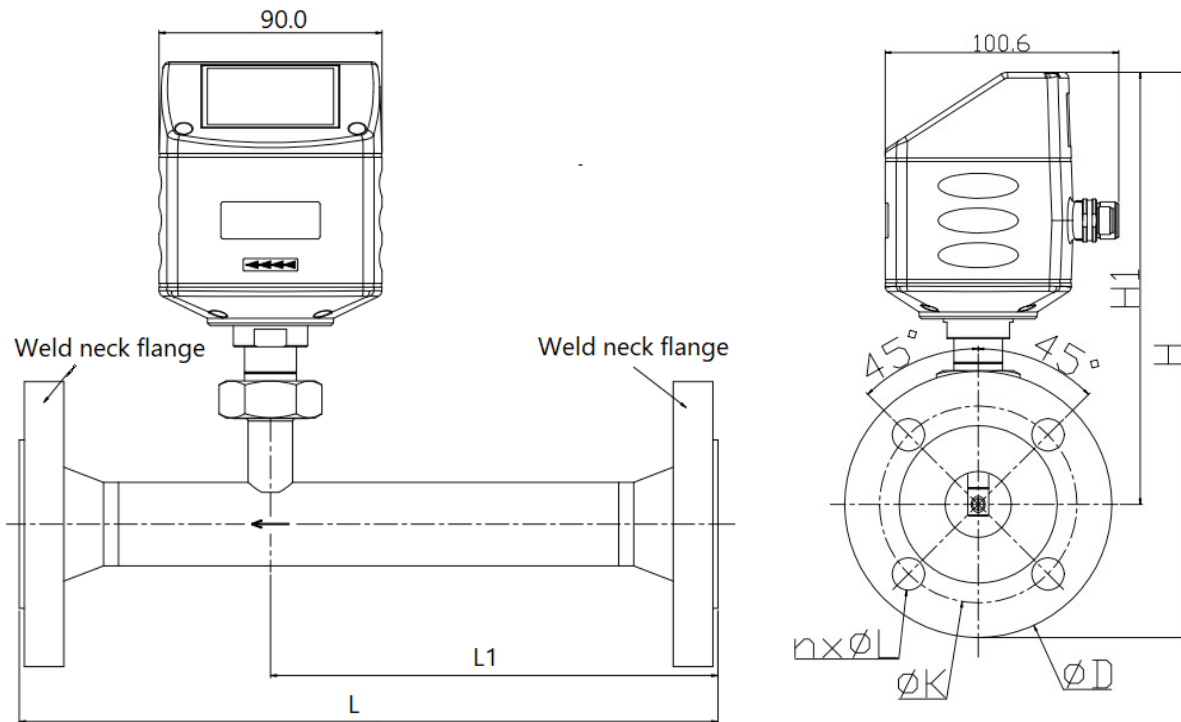

Type	Pipe nominal size inch(DN)	L total length [mm]	L1 inlet length [mm]	H total height [mm]	H1 from pipe center to casing top [mm]	Flange (EN 1092-1 PN40)		
						ØD (mm)	ØK (mm)	n x ØL (mm)
S421-1/2"	1/2"(DN15)	300	210	234.2	186.7	95	65	4xØ14
S421-3/4"	3/4"/(DN20)	475	275	239.2	186.7	105	75	4xØ14
S421-1"	1"/(DN25)	475	275	244.2	186.7	115	85	4xØ14
S421-1 1/4"	1 1/4"/(DN32)	475	275	256.7	186.7	140	100	4xØ18
S421-1 1/2"	1 1/2"/(DN40)	475	275	261.7	186.7	150	110	4xØ18
S421-2"	2"/(DN50)	475	275	269.2	186.7	165	125	4xØ18
S421-2 1/2"	2 1/2"/(DN65)	475	275	287.1	194.6	185	145	8xØ18
S421-3"	3"/(DN80)	475	275	301	201.0	200	160	8xØ18

Type	Pipe nominal size inch(DN)	L total length h [mm]	L1 inlet length [mm]	H total height [mm]	H1 from pipe center to casing top [mm]	Flange (ANSI/B16.5 class 300)		
						ØD (mm)	ØK (mm)	n x ØL (mm)
S421-1/2"	1/2"/ (DN15)	300	210	234.2	186.7	95.2	66.5	4xØ15.7
S421-3/4"	3/4"/ (DN20)	475	275	245.4	186.7	117.3	82.5	4xØ19
S421-1"	1"/ (DN25)	475	275	248.7	186.7	123.9	88.9	4xØ19
S421-1 1/4"	1-1/4"/ (DN32)	475	275	253.4	186.7	133.3	98.5	4xØ19
S421-1 1/2"	1-1/2"/ (DN40)	475	275	264.4	186.7	155.4	114.3	4xØ22.3
S421-2"	2"/ (DN50)	475	275	269.3	186.7	165.1	127.0	4xØ19
S421-2 1/2"	2 1/2"/ (DN65)	475	275	289.9	194.6	190.5	149.3	8xØ22.3
S421-3"	3"/ (DN80)	475	275	305.8	201.0	209.5	168.1	8xØ22.3

8 Determine the Installation Point

To maintain the accuracy stated in the technical data, the device must be installed inline and fitted to tubes with the same diameter. Please make sure that it has unhindered flow characteristics.

Unhindered flow characteristics are achieved if the section in front of the device (inlet) and behind the device (outlet) are sufficiently long, absolutely straight, and free of obstructions such as edges, seams, curves etc..

Please consider that enough space exists at your site for an adequate installation as described in this manual.



ATTENTION!

A wrong measurement is possible if the device is not installed correctly.

Notes:

- Careful attention must be paid to the design of the inlet and outlet section. Obstructions can cause counter-flow turbulence as well as turbulence in the direction of the flow.
- The flow meter is for indoor use only! At an outdoor installation, the flow meter must be protected from solar radiation and rain.
- It is strongly recommended not to install S421 permanently in a wet environment such as the place right after a compressor outlet.

8.1 Add the Required Inlet and Outlet Sections

The thermal measuring principle is sensible to inlet and outlet conditions. It is recommended that the following minimum straight inlet and outlet sections must be maintained to ensure an accurate measurement.

Flow meters should be always installed upstream from obstacles such as valves, filter, reductions etc. In common the device should be installed as far as possible away from any disturbances.

The S421 comes with straight inlet and outlet sections. Nevertheless, depending on the installation conditions, additional straight inlet and outlet sections must be added to the measuring section to meet the minimum inlet requirements.

The length of the additional inlet and outlet sections depend on the pipe inner diameter, inlet length, and outlet length.

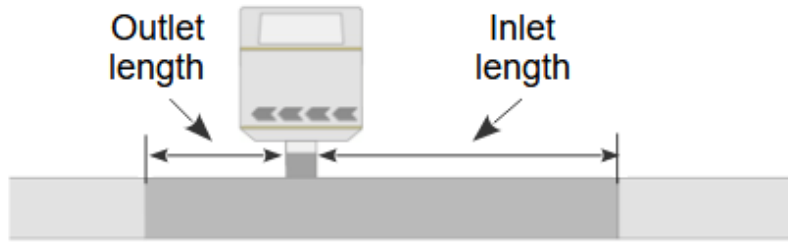

Inlet length and outlet length indicate the straight inlet section and outlet section equipped on the S421.

Pipe size	DN15	DN20	DN25	DN32	DN40	DN50	DN65	DN80
Pipe inner diameter (mm)	16.1	21.7	27.3	36.0	41.9	53.1	68.9	80.9
Inlet length (mm)	210.0	275.0	275.0	275.0	275.0	275.0	275.0	275.0
Outlet length (mm)	90.0	200.0	200.0	200.0	200.0	200.0	200.0	200.0

Refer to the installation types below and select your additional straight inlet and outlet sections from the table. These must be taken into account on site during installation.

1. Slight curve (bend < 90°)

$A = 15 \times \text{Inner diameter} - \text{Inlet length}$

$B = 5 \times \text{Inner diameter} - \text{Outlet length}$

A: additional straight inlet section B: additional straight outlet section



Pipe size	DN15	DN20	DN25	DN32	DN40	DN50	DN65	DN80
A (mm)	30	50	130	270	350	520	760	940
B (mm)	0	0	0	0	10	70	140	200

2. Expansion, reduction, and the 90° bend

A = 20 x Inner diameter – Inlet length

B = 5 x Inner diameter – Outlet length

A: additional straight inlet section B: additional straight outlet section

Expansion

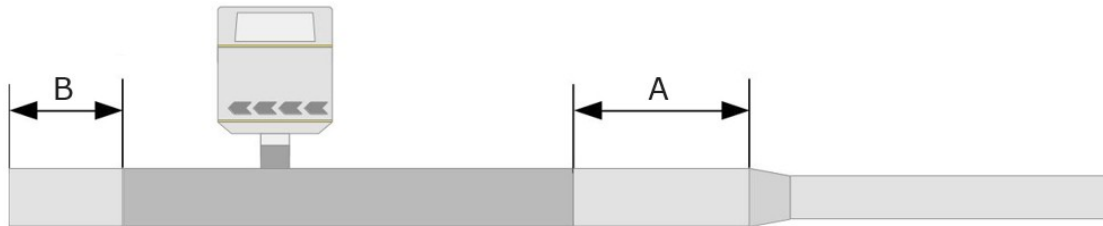

Reduction

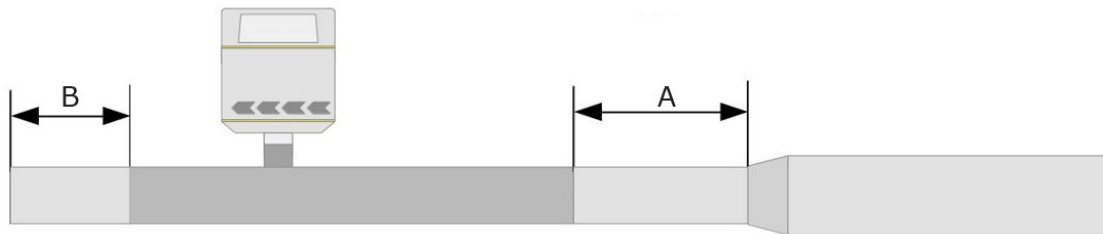

90° bend

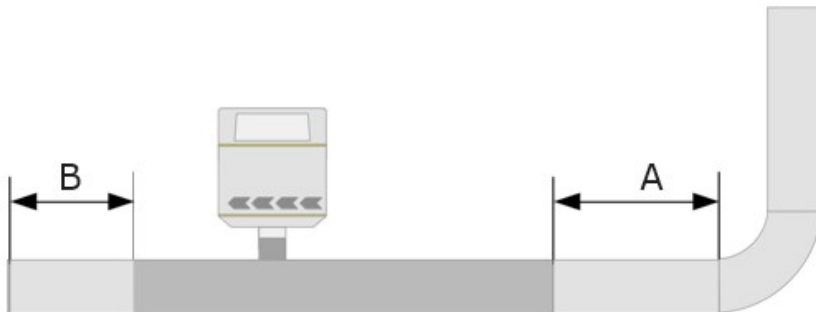

Pipe size	DN15	DN20	DN25	DN32	DN40	DN50	DN65	DN80
A (mm)	110	160	270	450	560	790	1100	1340
B (mm)	0	0	0	0	10	70	140	200

3. 2 X 90° bend and T-piece

A = 25 x Inner diameter – Inlet length

B = 5 x Inner diameter – Outlet length

A: additional straight inlet section B: additional straight outlet section

2 x 90° bend

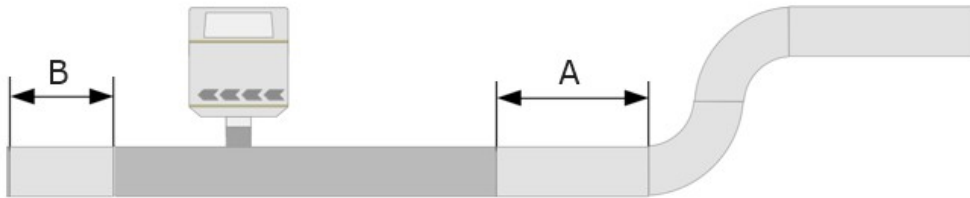

T-piece

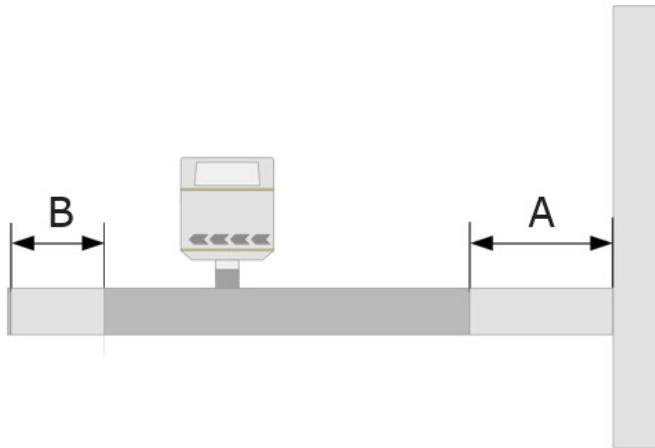

Pipe size	DN15	DN20	DN25	DN32	DN40	DN50	DN65	DN80
A (mm)	190	270	410	630	770	1050	1450	1750
B (mm)	0	0	0	0	10	70	140	200

4. 3 dimensional bend

A = 40 x Inner diameter – Inlet length

B = 5 x Inner diameter – Outlet length

A: additional straight inlet section B: additional straight outlet section

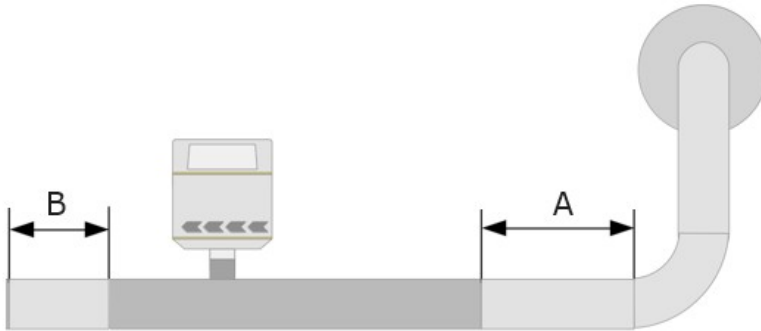

Pipe size	DN15	DN20	DN25	DN32	DN40	DN50	DN65	DN80
A (mm)	430	590	820	1170	1400	1850	2480	2960
B (mm)	0	0	0	0	10	70	140	200

5. Shut-off valve and filter or similar (unknown objects)

A = 50 x Inner diameter – Inlet length

B = 5 x Inner diameter – Outlet length

A: additional straight inlet section B: additional straight outlet section

Shut-off valve

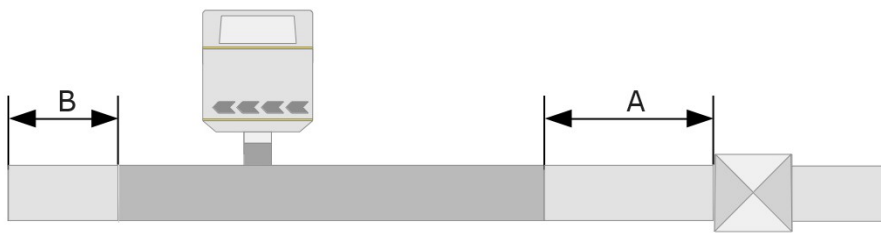

Filter or similar (unknown objects)

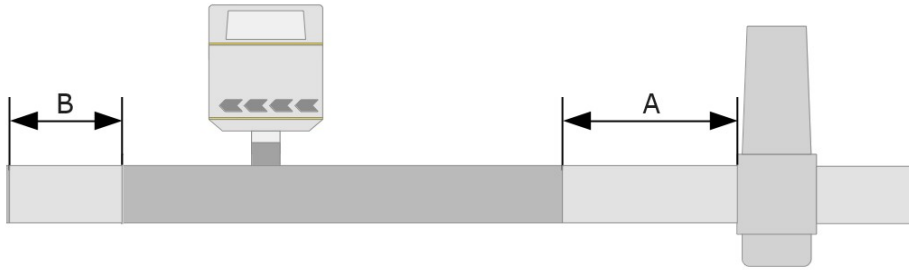

Pipe size	DN15	DN20	DN25	DN32	DN40	DN50	DN65	DN80
A (mm)	0	810	1090	1530	1820	2380	3170	3770
B (mm)	0	0	0	0	10	70	140	200

Notes:

- If there is any combination of the situations above, the longest straight inlet section must be maintained.
- The length of inlet and outlet sections depicted above are minimum requirement; longer inlet sections are preferable. That is, if it is possible to achieve a longer straight inlet section than the minimum specified during installation, this is preferable.
- When the required straight inlet section cannot be achieved, it is recommended to add a flow conditioner at the inlet of the flow meter to obtain an optimum flow profile. For introduction of the flow conditioner, see Appendix - Flow Conditioner.

9 Installation

Before installing, make sure that all components listed below are included in your package.

Qty	Description	Item No.
1	S421 Thermal Mass Flow Meter	S695 4120 / S695 4121
1	Sealing ring	NA
2	Depending on orders: M12 plug or M12 cable	Plug: C219 0059 Cable: A553 0104/A553 0105/A553 0146
1	Instruction manual	NA
1	Calibration certificate	NA
1	Measuring section	A1301 ... A1308 (R thread) A1321 ... A1328 (Flange, EN-1092-1) A1341 ... A1348 (Flange, ANSI 16.5)

9.1 Install the Flow Meter

The S421 is shipped with a mounted measurement section. The flow meter must be installed correctly to the flow direction in the tube. When you face the S421 display, the gas must flow from the left to the right. Observe the flow direction indicated on the housing. Make sure that the flow direction matches the flow direction of the gas. The gas flows from the inlet (long pipe section) to the outlet (short pipe section), as illustrated in the picture below.

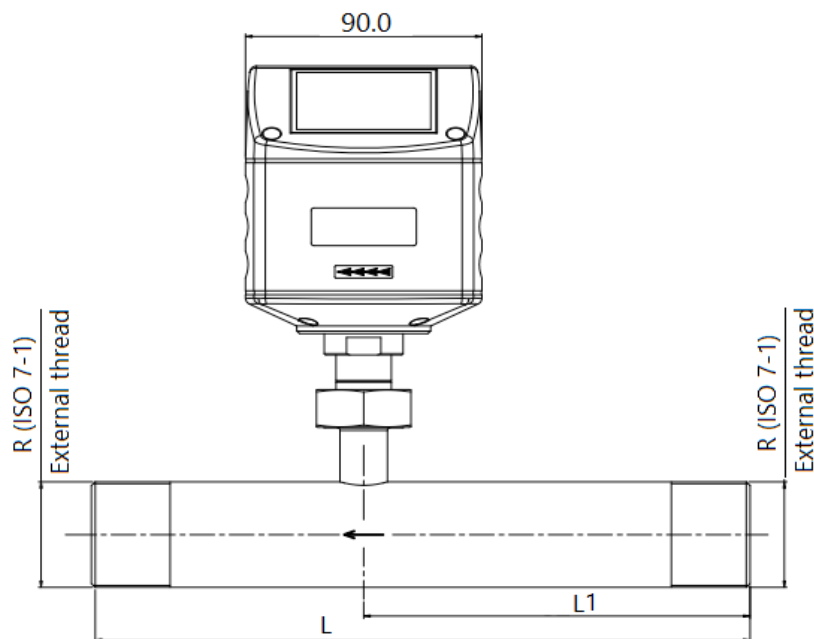

Note: The flow meter can be installed in any orientation (horizontal,

vertical, side and upside-down). Please consider the needed straight inlet and outlet sections described in section 8.1 Add the Required Inlet and Outlet Sections.

9.2 Remove the Flow Meter

The following describes how to remove the flow meter appropriately.



ATTENTION!

Remove the flow meter only when the system is in a pressureless condition.



1. Hold the flow meter.
2. Release the connection nut at the connection thread.
3. Pull out the shaft slowly.
4. The measuring section can be closed with the optional closing cap so that the system can operate normally during maintenance of the flow meter.



Re-installation after maintenance:

1. Place the O-ring into the recess of the connection nut.
2. Insert the flow meter back to the pipe. (The S421 comes with the Poka-Yoke design for simple and error-free insertion.)
3. Tighten the connection nut.

9.3 Electrical Connection

The flow meter comes with external connectors "A" and "B" through which the flow meter is connected with external control devices such as PLC.

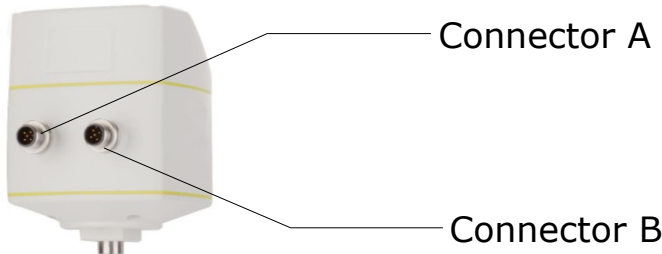

9.3.1 M12 Connector Types

The following table lists the type of the M12 connector based on the output option.

P/N	Output option	Connector type
A1410	4 ... 20 mA + Pulse	A = M12 (5-pin); B = M12 (5-pin)
A1411	Modbus/RTU	A = M12 (5-pin); B = M12 (5-pin)
A1413	4 ... 20 mA + Pulse compatible to S400	A = M12 (5-pin); B = M12 (5-pin)
A1424	Modbus/TCP	A = M12 (5-pin); B = M12 (8-pin X-coded)

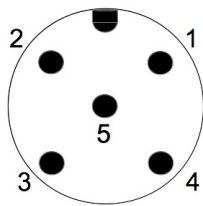

General connection pins, male
(View onto the connector)

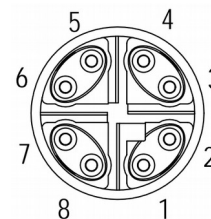

Ethernet connection pins, male
(View onto the connector)

M12 pin assignment

Output Type	Connector	Pin 1	Pin 2	Pin 3	Pin 4	Pin 5
4 ... 20mA plus pulse (P/N: A1410)	A	SDI	-V _B	+V _B	DIR	DIR
	B	N/A	SW	SW	+I _{isolated}	-I _{isolated}
Modbus/RTU (P/N: A1411)	A	SDI	-V _B	+V _B	DIR	DIR
	B	GND _M	-V _B	+V _B	D+	D-
4 ... 20mA+pulse, compatible to S400 (P/N: A1413)	A	SDI	-V _B	+V _B	+I _{active}	+P _{active}
	B	NA	-V _B	DIR	SW	SW
Modbus/TCP (P/N: A1424)	A	SDI	-V _B	+V _B	DIR	DIR
	B	See section 9.3.2.				
Wire color	/	Brown	White	Blue	Black	Grey

Legend to pin assignment

SDI	Digital signal (internal use)
-V _B	Negative supply voltage
+V _B	Positive supply voltage
DIR	Flow direction input (Flow direction switch)
SW	Isolated pulse output (switch)
+I _{isolated}	Positive 4 ... 20 mA signal (isolated)
-I _{isolated}	Negative 4... 20 mA signal (isolated)
GND _M	Ground for Modbus/RTU
D+	Modbus/RTU data +
D-	Modbus/RTU data -
+I _{active}	Active 4 ... 20 mA signal (related to -V _B)
+P _{active}	Active pulse output (related to -V _B)
N/A	Not applicable



ATTENTION!

Do not screw the M12 connector using force. Otherwise it might damage the connecting pins.

9.3.2 Ethernet Connection

The flow meter can be powered in the following ways:

- Using connector A
- Using the PoE (Power over Ethernet) function, which is integrated into the Ethernet connection on connector B.

To power the unit via PoE, a network switch that supports PoE is needed. PoE comes into two standards:

- Type A: The PoE switch powers the device via Pair 2 (Pin 1 and Pin 2) and Pair 3 (Pin 3 and Pin 6)
- Type B: The PoE switch powers the device via Pair 1 (Pin 4 and Pin 5) and Pair 4 (Pin 7 and Pin 8)

This flow meter supports both types.

Connection cable – M12 X-coded to RJ45

When Modbus/TCP is chosen as the flow meter output, a 5 m 8-pore cable is supplied in the delivery package. The cable has the M12 and RJ45 plugs on the ends. RJ45 is used to connect the flow meter to a PoE switch.

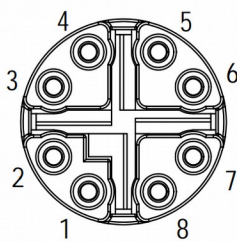
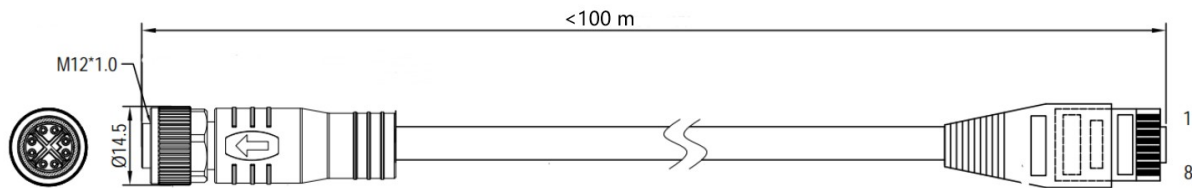

Front view of the M12 connector, female

The 8-position pin/pair assignment on the RJ45 side must comply with the T568B wiring method. The flow meter does not support T568A wiring method.

M12 X-coded	RJ45	Signal	Color code	Pair designation
1	1	Tx+ / +V _B / -V _B	White-Orange (W-O)	Pair 2
2	2	Tx- / +V _B / -V _B	Orange (O)	
3	3	Rx+ / -V _B / +V _B	White-Green (W-G)	Pair 3
4	6	Rx- / -V _B / +V _B	Green (G)	
5	7	NA / -V _B	White-Brown (W-BR)	Pair 4
6	8	NA / -V _B	Brown (BR)	
7	5	NA/ +V _B	White-Blue (W-BL)	Pair 1
8	4	NA/ +V _B	Blue (BL)	

10 Signal Outputs

10.1 Analog Output

The flow meter can provide an analog output of 4 ... 20 mA. This output can be scaled to match the desired measuring range. The standard scaling is from 0 to max flow.

The corresponding flow rates to different pipe sizes can be calculated using the free "Flow range calculator" tool available in <http://www.suto-itec.com>. For more information about how to download, see section [6.5](#).

For other ranges, please contact the manufacturer.

10.2 Pulse Output

The flow meter outputs one pulse per a consumption unit. This pulse output can be connected to an external pulse counter to count the total consumption. The number of m³ per second is summed up and indicated after one second. Pulse length depends on flow rate.

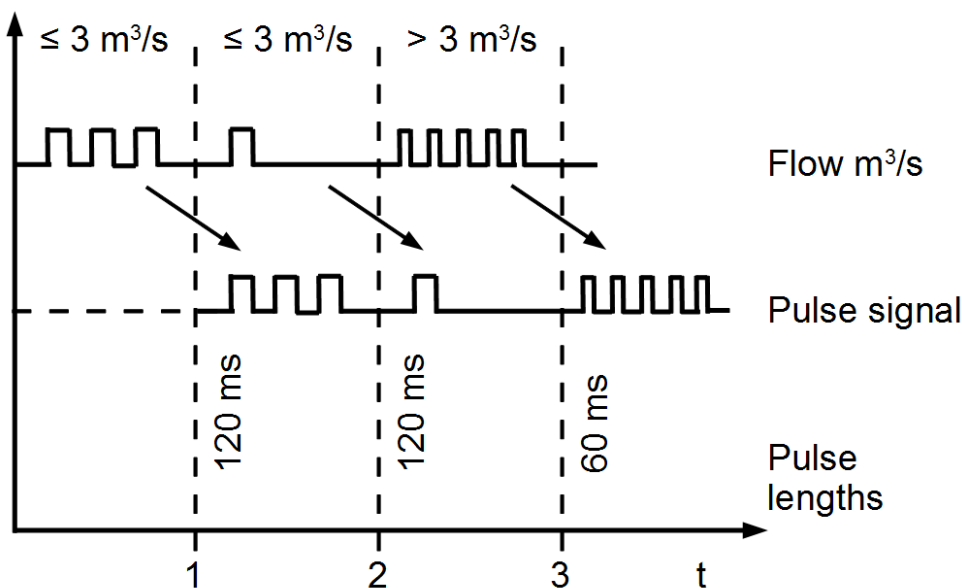

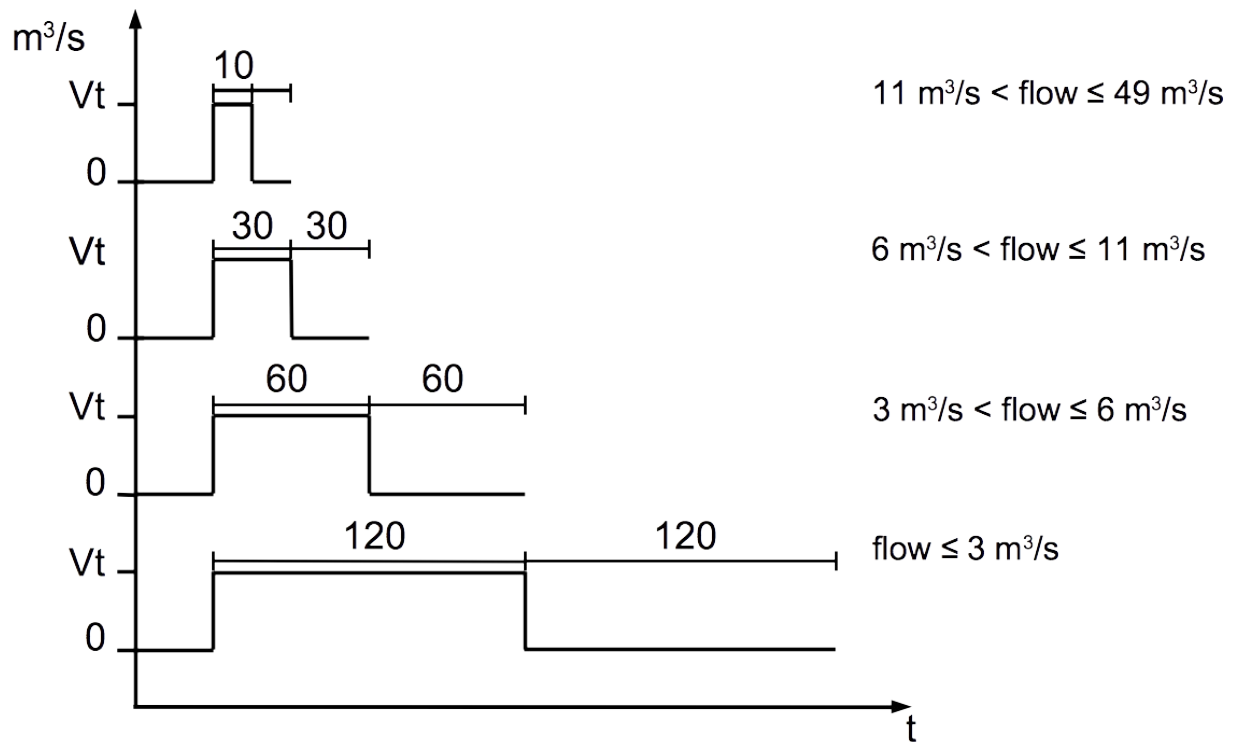

If the flow rate is too high, the S421 cannot output the pulses with default settings (one pulse per consumption unit). In this case, you can set the pulse to 1 pulse per 10 consumption units or 1 pulse per 100 consumption units, using the S4C-FS service App (S4C-FS) or a connected display.

Example: with setting of 1 pulse per 10 m³, the flow meter sends one pulse each 10 m³.

Volumetric flow [m³/s]	Volumetric flow [m³/h]	Pulse length [ms]	Max. pulse output per hour
≤ 3	≤ 10800	120	1080
> 3	> 10800	60	2880
> 6	> 21600	30	3960

10.2.1 Pulse Connection Diagrams (A1410)

Using the isolated pulse switch (Connector B: Pin 2 and 3)

Variant 1:

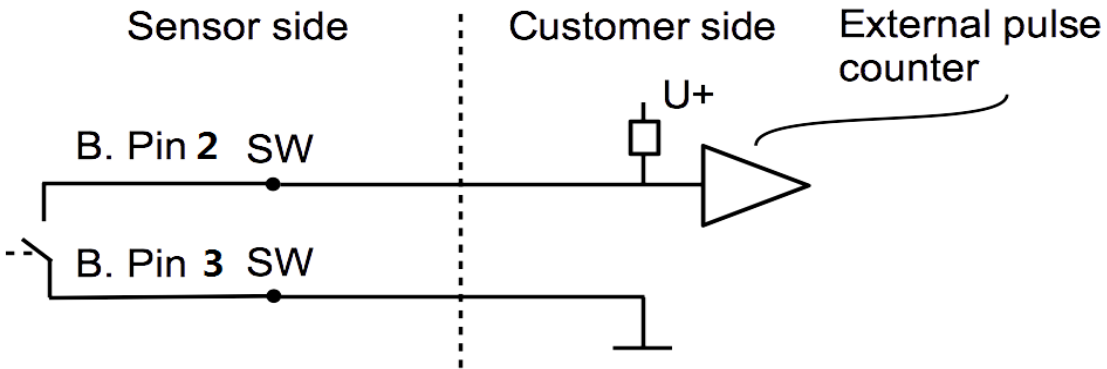

Variant 2:

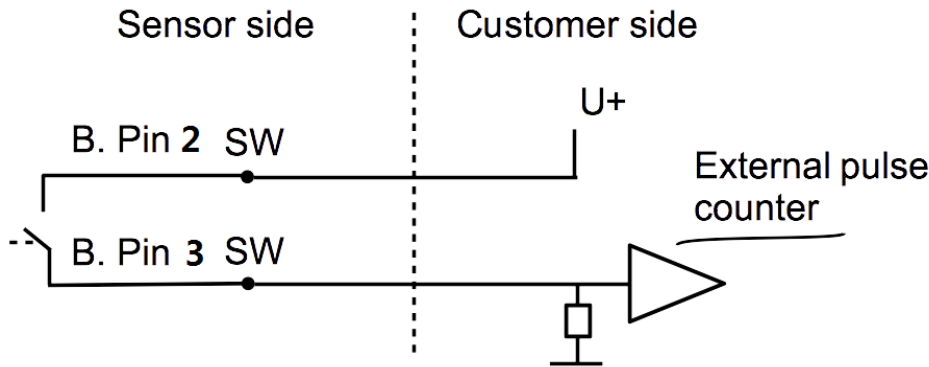

10.2.2 Pulse Connection Diagrams (A1413)

Using the isolated pulse switch (Connector B: Pin 4 and 5)

Variant 1:

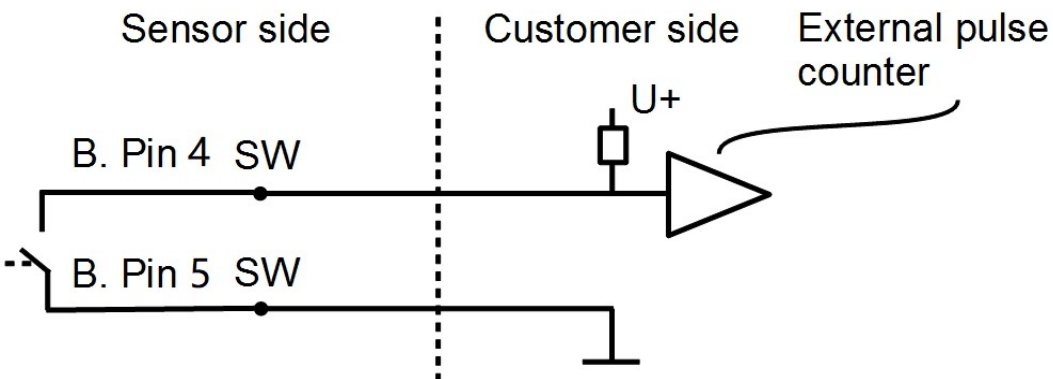

Variant 2:

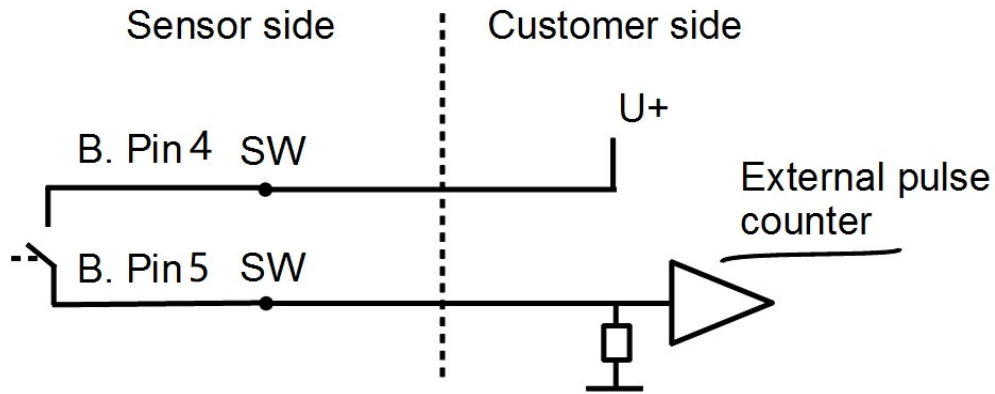

Using the Pulse Output P+ (Connector A: Pin 5)

Variant 1:

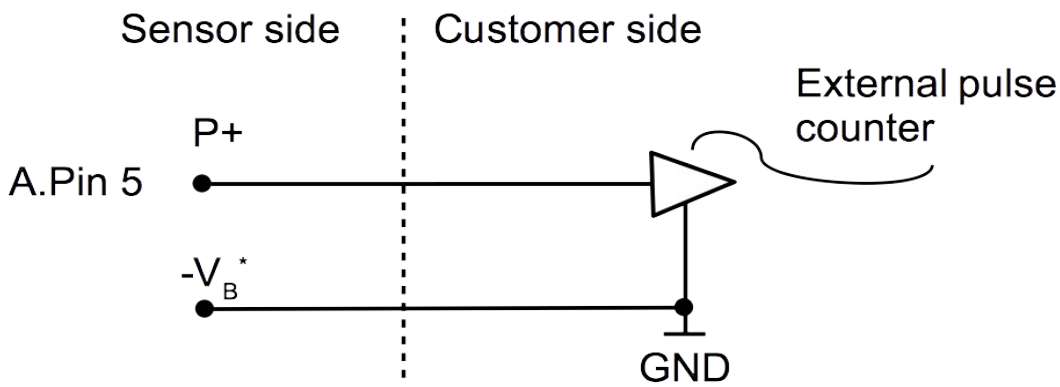

Variant 2:

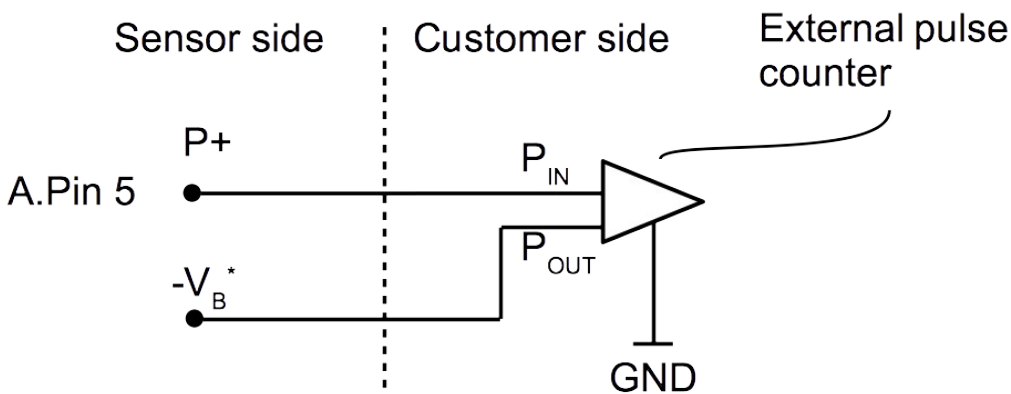

*GND of the external pulse counter might be connected to $-V_B$ of the flow meter.

10.3 Modbus Interface

10.3.1 Modbus Information

The default settings of the Modbus interface are as follows:

Communication parameters (Modbus/RTU)

Baud rate	: 19200
Device address	: Last two digits of serial number
Framing / parity / stop bit	: 8, N, 1
Response time	: 1 second
Response delay	: 0 ms
Inter-frame spacing	: 7 char

Communication parameters (Modbus/TCP)

DHCP	: Yes
MAC	: Set ex-factory
IP address	: Dynamic or Static
Subnet	: Dynamic or Static
Gateway	: Dynamic or Static
Timeout	: ≥ 200 ms

Response message that the device returns to the master:

- Function code: 03

The information of the byte order is shown in the table below:

Byte Order	Sequence				Data Type
	1st	2nd	3rd	4th	
1-0-3-2	Byte 1 (MMMMMMMM*)	Byte 0 (MMMMMMMM *)	Byte 3 (SEEEEEEE)	Byte 2 (EMMMMMMM *)	FLOAT
1-0-3-2	Byte 1	Byte 0 LSB	Byte 3 MSB	Byte 2	UINT32 INT32
1-0	Byte 1 MSB	Byte 0 LSB	---	---	UINT16 INT16
1-0	Byte 1 XXX *	Byte 0 DATA	---	---	UINT8 INT8

* S: Sign, E: Exponent, M: Mantissa, XXX: no value

Explanations of MSB and LSB

MSB MSB refers to Most Significant Byte first, which follows the Big-Endian byte order.
For example, if the main system follows the MSB first order:
When the 4-byte floating number, in the order of Byte1-Byte0-Byte3-Byte2, is received from the slave (sensor), the master must change the byte order to Byte3-Byte2-Byte1-Byte0 for the correct display of the value.

LSB LSB refers to Least Significant Byte first, which follows the Little-Endian byte order.
For example, if the main system follows the LSB first order:
When the 4-byte floating number, in the order of Byte1-Byte0-Byte3-Byte2, is received from the slave (sensor), the master must change the byte order to Byte0-Byte1-Byte2-Byte3 for the correct display of the value.

Notes:

- Modbus communication settings as well as other settings can be changed by the service App **S4C-FS** or the optional device display.
- In the Modbus/TCP mode, a slave device does not support concurrent connections because it can respond to only one polling message at a time.

Available measurement channels (Modbus/RTU and Modbus/TCP)

Register address	Length	Format	Channel name	R/W
6	4-Byte	FLOAT	Flow	R
8	4-Byte	UINT32	Consumption	R

10.3.2 Connect Modbus/RTU Devices to a Master

Sensors and devices with a Modbus/RTU output can be connected to a Modbus master device. This master can be either SUTO displays and gateways or any third-party Modbus/RTU master.

See below specifications of the Modbus/RTU connections. Modbus/RTU Cable Length

A Modbus/RTU bus line has limitations which shall not be exceeded, otherwise the communication might not be stable.

- The maximum total bus length must not exceed 1200 m.
- The stub length to each node must not exceed 30 cm.

See the picture below for details.

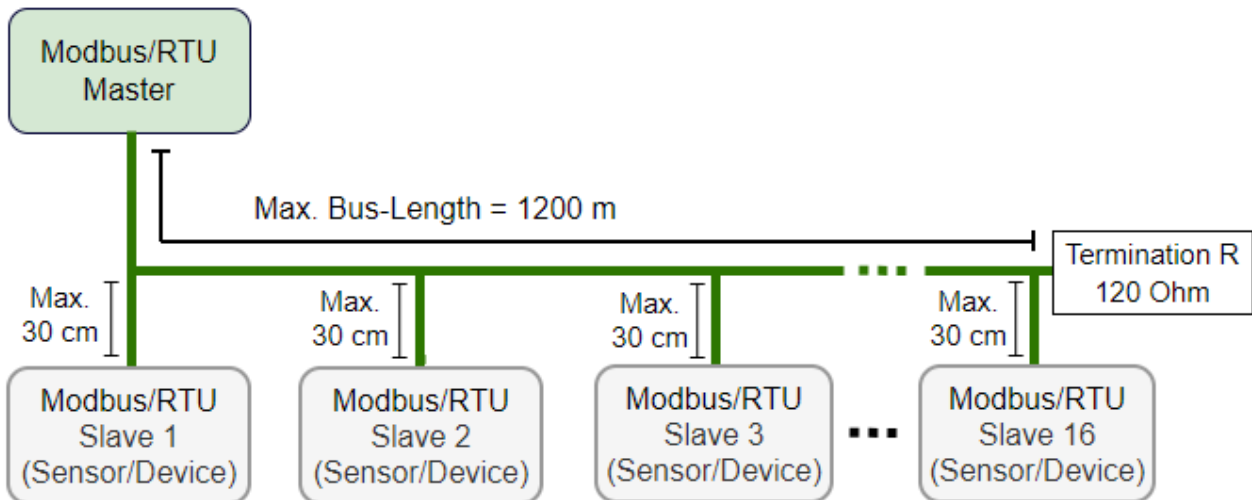

10.3.2.1 Modbus/RTU Wiring and Cable Type

To ensure a stable communication a twisted-pair bus cable must be chosen to set up the Modbus/RTU communication.

- Bus-cable specifications must follow the EIA485 Standard, must be twisted pair and shielded, for example 2 x 2 x 0.22 mm², Li-2YCY (A553 0123).
- The shield must be connected at one end to the master GND connection.
- At the end of the bus, a 120 Ohm resistor should be placed a termination resistor.

See the below picture for details.

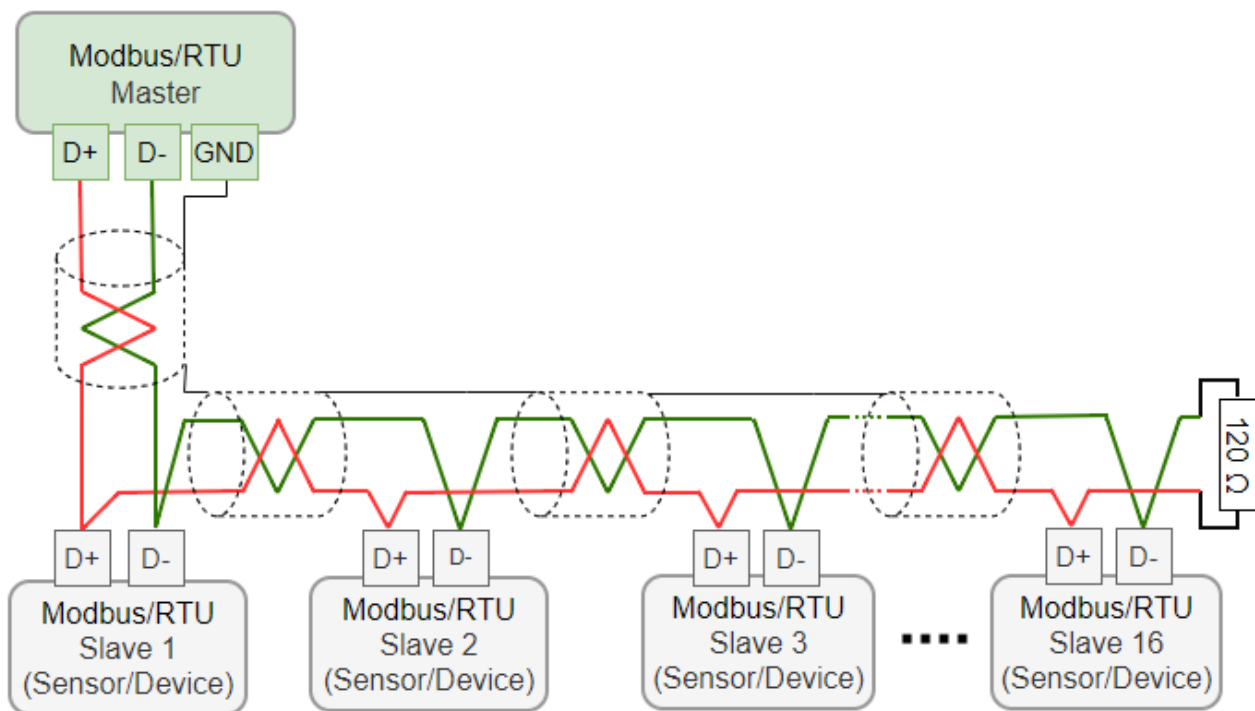

10.3.2.2 Daisy-Chain using RS-485 Splitter

SUTO devices with M12 connectors can be easily connected in a Modbus/RTU daisy-chain using a M12 RS-485 splitter (A554 3310). Furthermore this allows to easily place the M12 termination resistor (C219 0055) at the last splitter in the bus-chain.

See example below for reference.

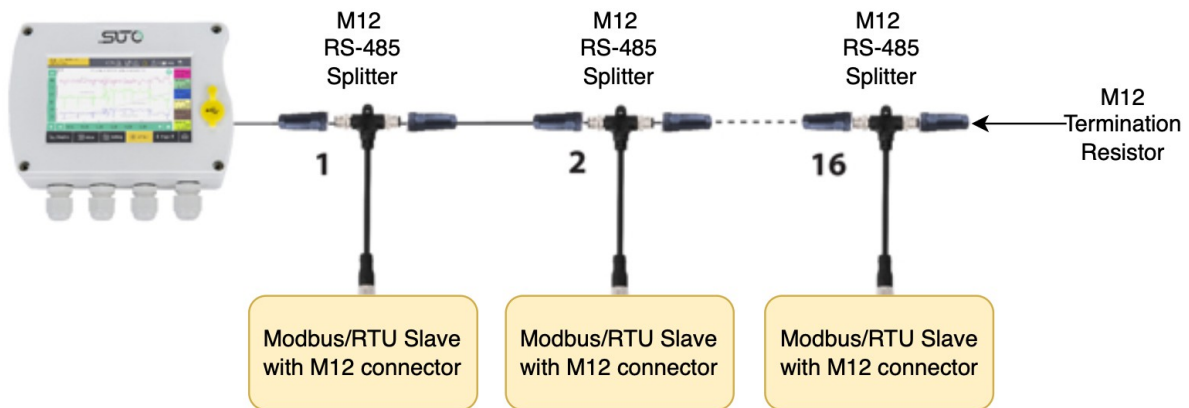

Connect Modbus/RTU slaves with M12 connectors to a daisy-chain using M12 RS-485 splitters.

The M12 RS-485 splitter (A554 3310) comes with two M12 connectors to easily wire the chain.

10.3.2.3 Topology of Modbus/RTU Daisy-Chain

The recommended bus topology is to connect devices as a daisy-chain, as shown in the figure in section 10.3.2. Other connection topologies are not recommended and should be avoided.

Avoid a connection of slaves to the master in ring or star topology.

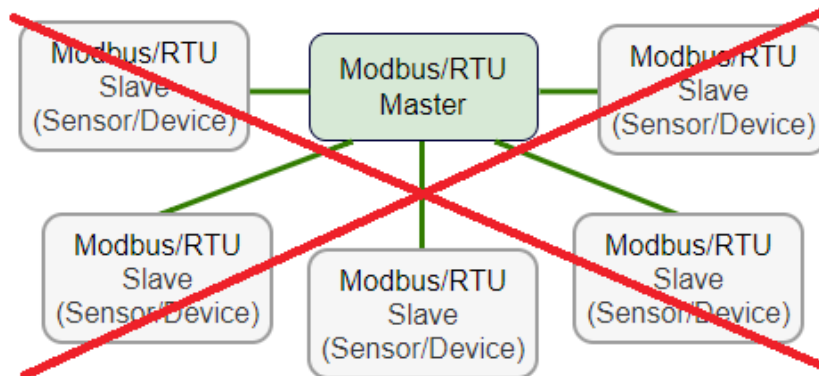

Avoid a star topology

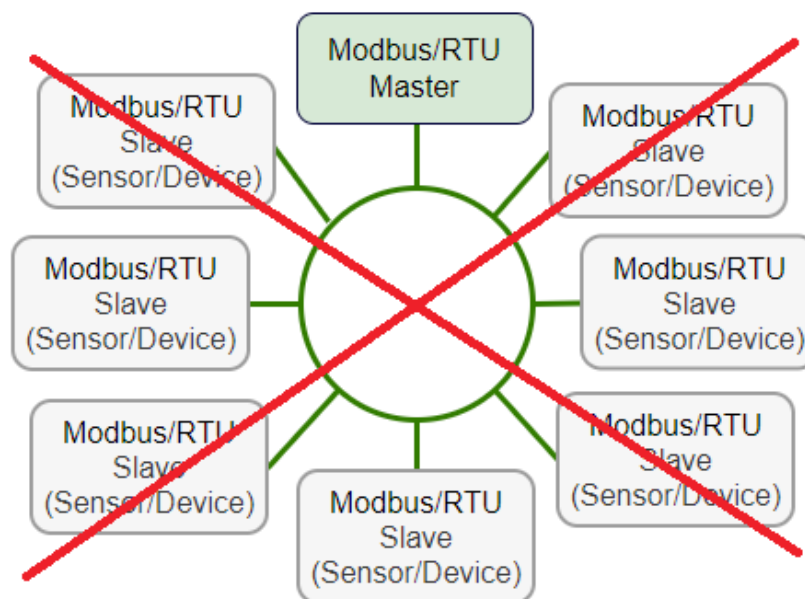

Avoid a ring topology

10.4 Connection between S421 Outputs and Customer Equipment

This section provides figures to show how outputs supported by the S421 connect with the customer equipment.

In the following figures, the **SUTO Instrument** indicates the S421.

Analog output (Isolated)

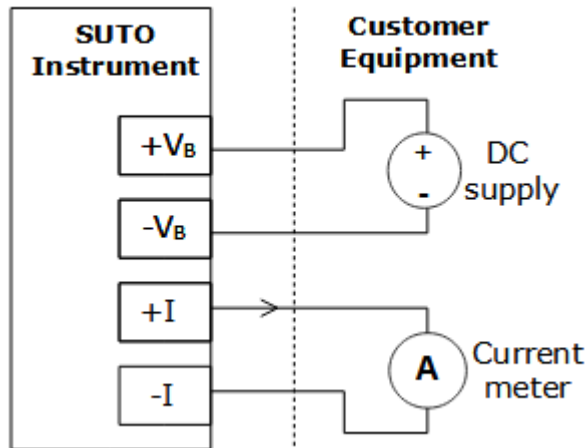

Analog output (3-wire)

Note: The output applies to option A1413.

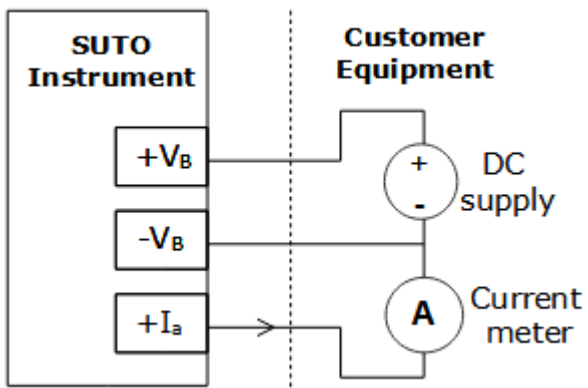

Pulse output (active)

Note: The output applies to option A1413.

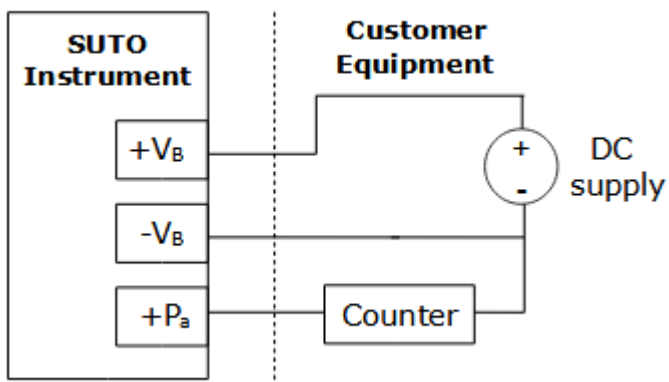

Modbus/RTU output

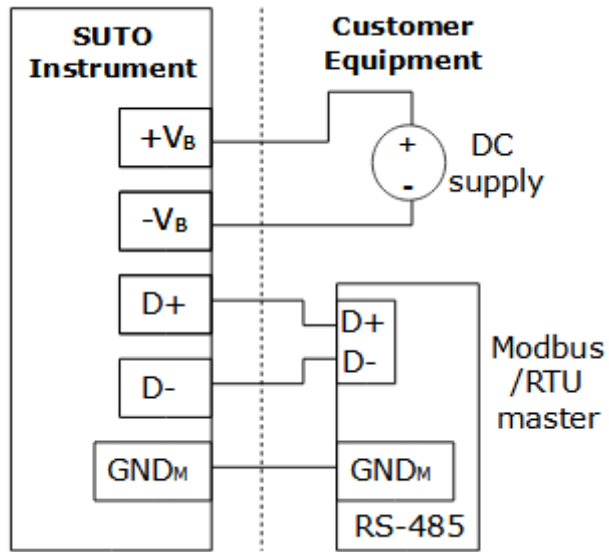

Modbus/TCP output with PoE

Class A

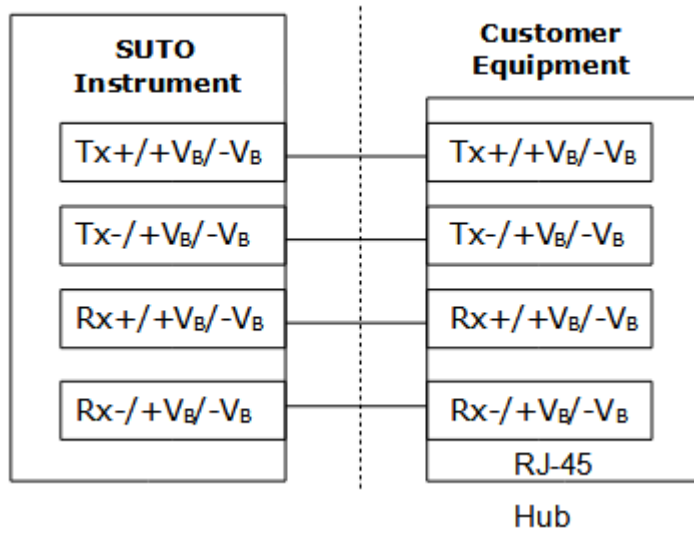

Class B

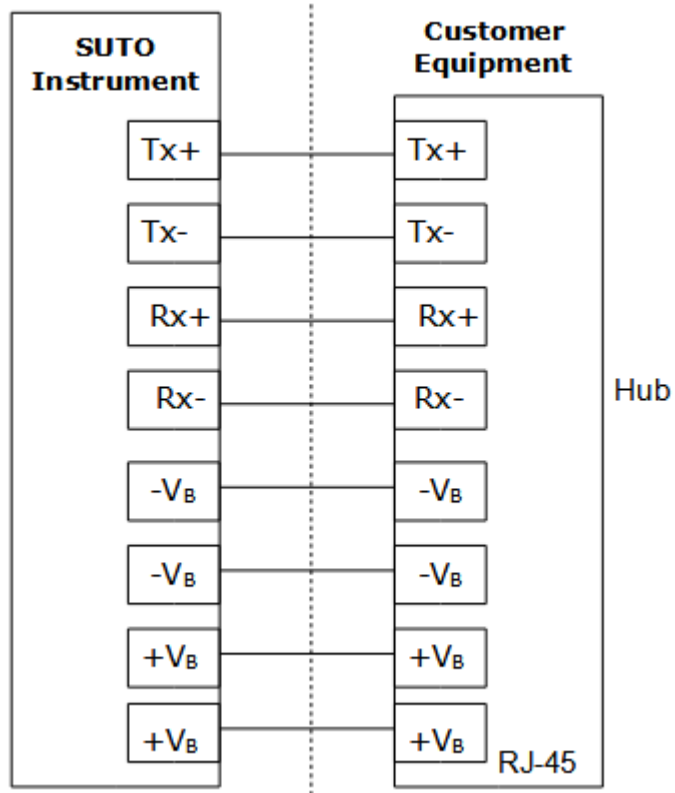

Modbus/TCP output with external power supply

Class A

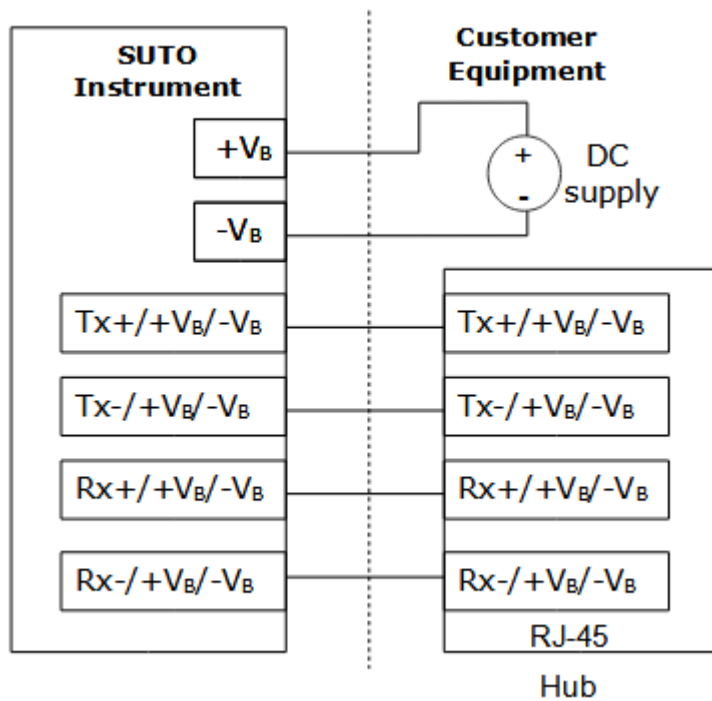

Class B

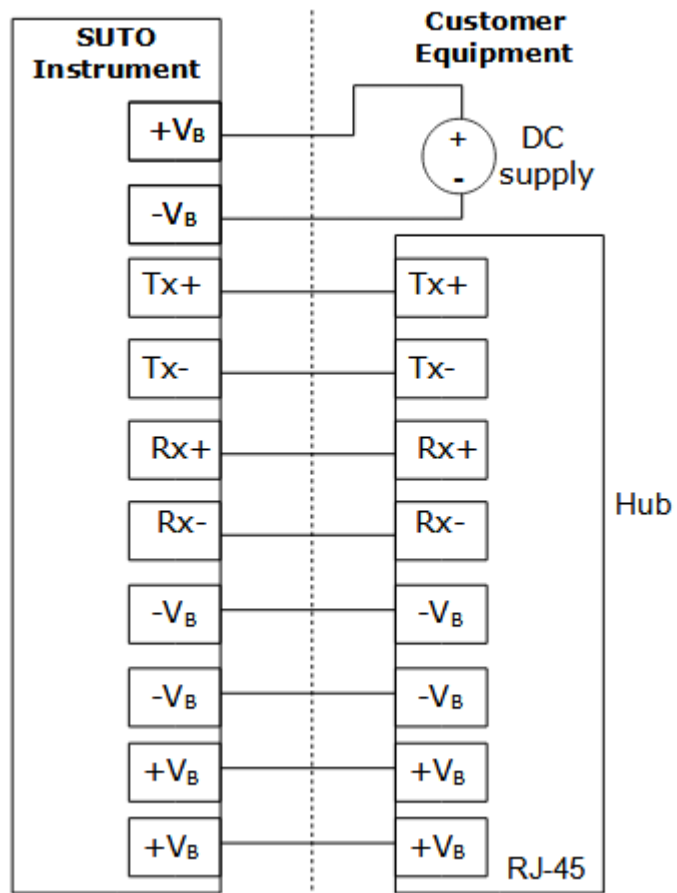

11 Configuration

After the installation is completed, change the flow meter settings if needed using the S4C-FS service app or the device display (optional).

11.1 Service App S4C-FS

The S4C-FS is a mobile phone App that enables you to view measurement readings and change settings for SUTO flow meters wirelessly.

You can download S4C-FS from Google Play Store or SUTO website, and install it as you do for any Apps on your mobile phone.

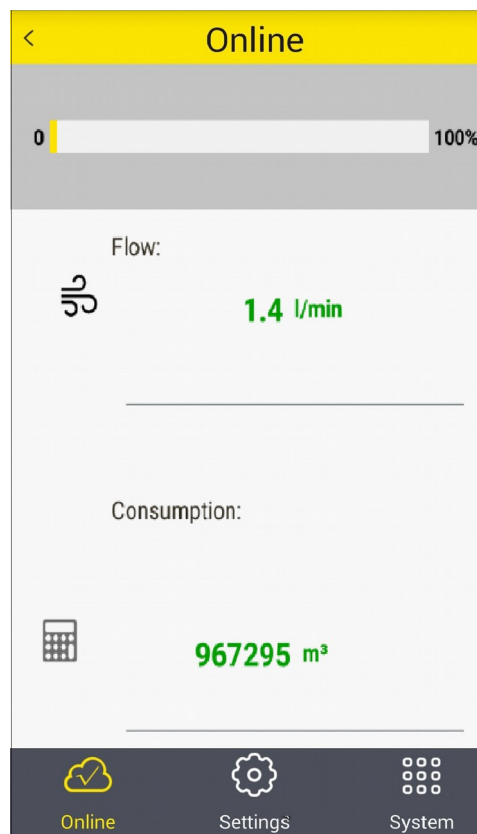

For more information about the description of the flow meter settings, see the *S4C-FS Instruction and Operation Manual*, which you can download from our website (Download > Search: S4C-FS).



ATTENTION!

Improper changes in the settings might lead to wrong measurement results! Contact the manufacturer in case that you are not familiar with the settings.

11.2 Device Display (Optional)

The device display enables you to do the following:

- View the online flow and consumption values.
- View error messages.
- Change the flow meter settings.



Operation keys



Enter key

Press for >3 seconds to enter the configuration mode.
Press to confirm your selection.



Up key

Press to choose a parameter item, entry box, or to adjust the value.



Down key

11.2.1 Start-up

After powering up, the display starts an initialization procedure. During the next eight seconds, the display will show the current software version and set up the connection with the flow meter. After it is completed, the display enters the standard mode, showing the online values as below.

Home page

The screenshot shows the home page of the flow meter. At the top is a green status bar containing icons for Bluetooth, a warning triangle, a temperature warning triangle, and a right-pointing arrow, along with the text 'Page 1/2'. Below the status bar is a horizontal bar with a scale from 0 to 100%, with an orange bar indicating the current flow value. The main display shows 'Flow: 14550.0 Nm³/min' and 'Consumption: 14550 m³'. Arrows point from the text labels to the corresponding elements in the screenshot.

- Status bar
- Moving bar to indicate flow value
- Measurement values

Icons shown in the status bar

Indicate status or warnings for the flow meter in service.

Icon	Description	Icon	Description
	Temperature over operating range		Pressure sensor damaged
	Flow over measuring range		Temperature sensor damaged
	Pressure over operating range		Flow direction

11.2.2 Operations

On the display, you can do the following settings: select gas type, select flow unit, reset consumption value, configure communication parameters, and more.

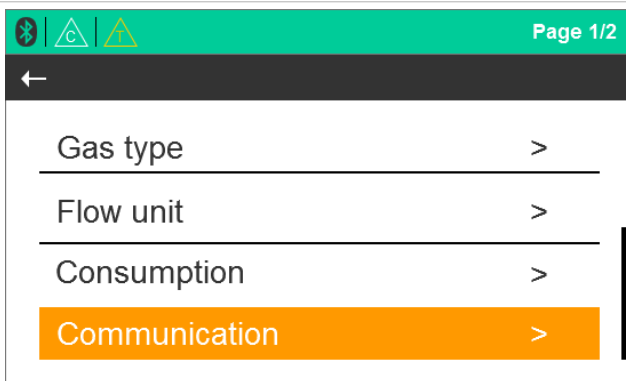

1. Press the "Enter" key for more than 3 seconds to enter the configuration mode.
2. Enter the unlock code: 12 using the "Up" and "Down" keys, and then press the "Enter" key to confirm.
3. Use the "Up" and "Down" keys to choose a setting that needs to be changed.

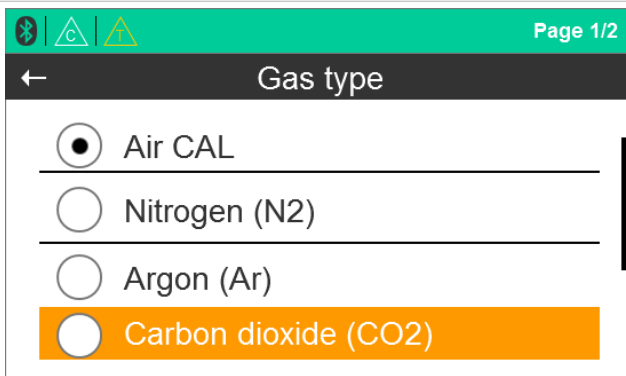

4. Use the "Up" and "Down" keys to select the desired entry box or adjust the values.
5. Press the "Enter" key to confirm the changes.

11.3 Perform Zero Flow Calibration

Use one of the following ways to perform the zero flow calibration: on the S4C-FS App or on the flow meter display.

11.3.1 On S4C-FS App

1. Click **Calibration**.

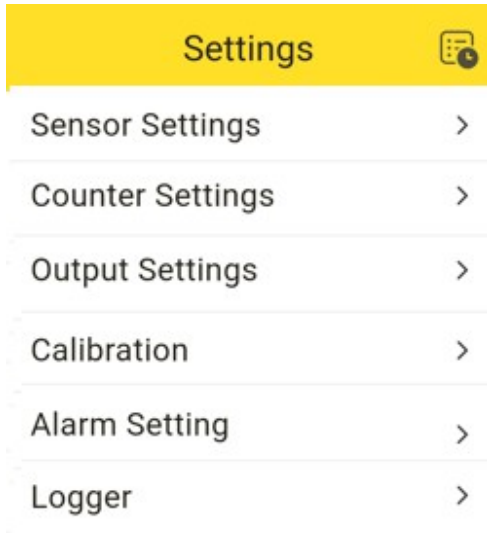

2. Click **Zero Flow Calibration**.

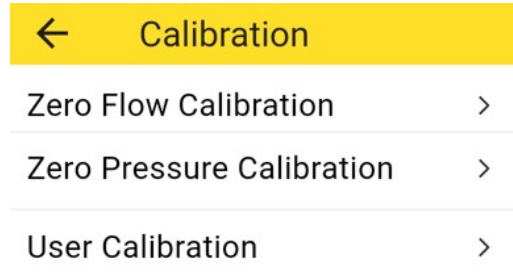

3. Attention message shows the recommended case for zero flow calibration. Click **Next** to perform the calibration.

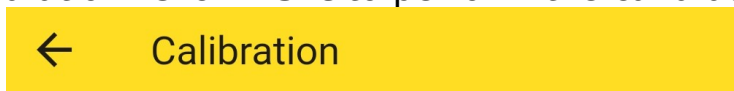

⚠ ATTENTION!

Zero flow calibration is recommended only in these cases:

- Sensor is operated at much higher pressure than 6 bar
- Sensor is used in a different gas than calibrated (default calibration gas is air)
- Sensor shows flow even though there is no flow in the pipe

Others than these cases this calibration is not required and not recommended!



11.3.2 On Flow Meter Display

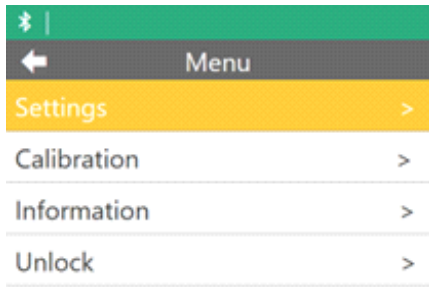

1. Click **Calibration**.

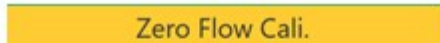

The original zero point would be erased.
Press enter key to continue...

2. Information page shows the original zero point would be erased, press **enter** key to continue.

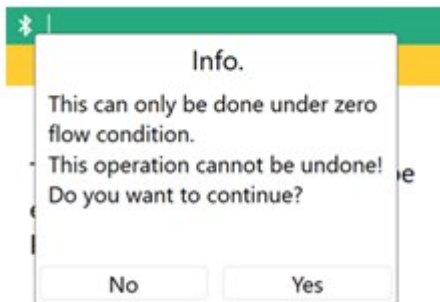

3. On the pop-up window, select **Yes** to perform the zero flow calibration.

11.3.3 Menu Map

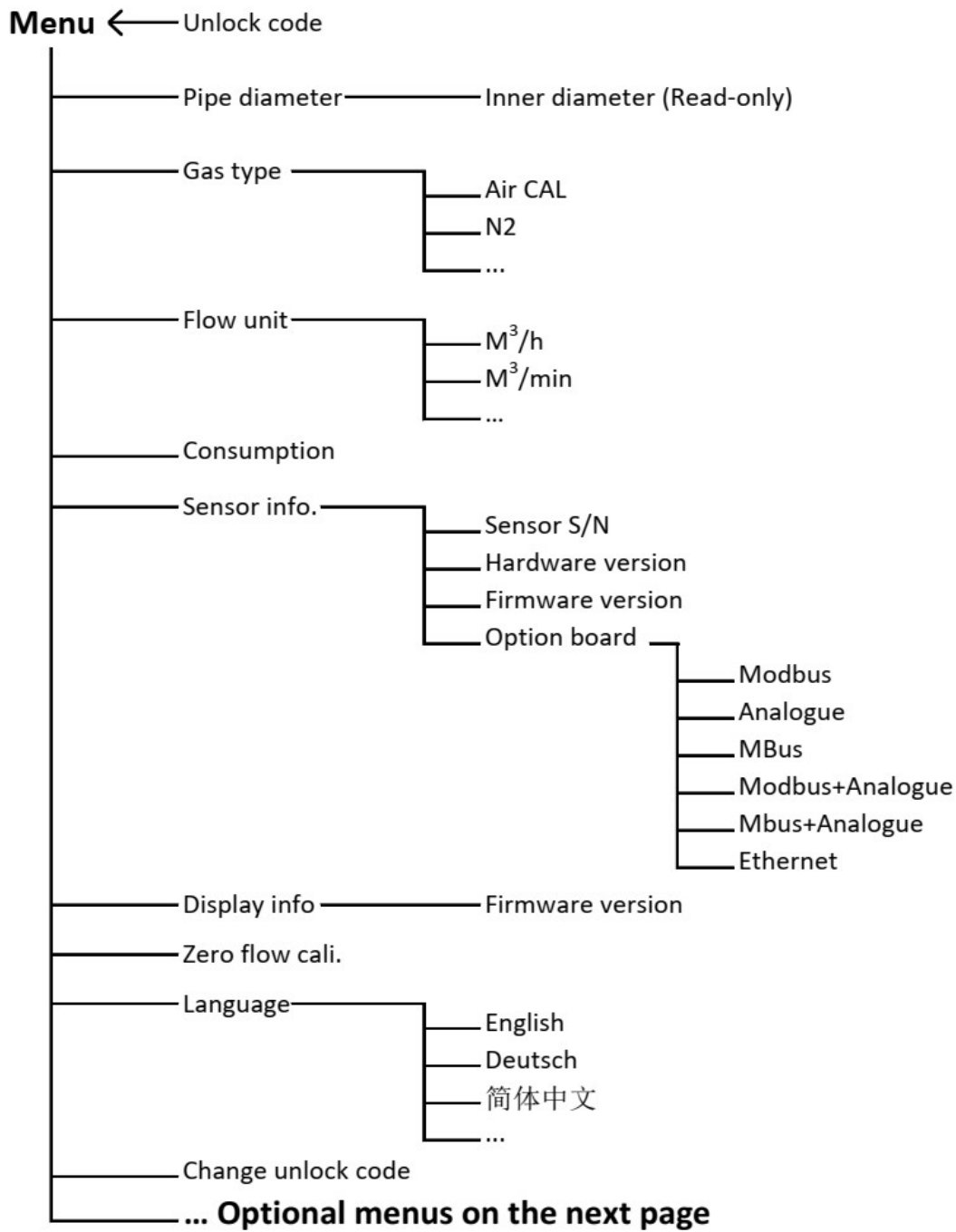

Menu (Continued)

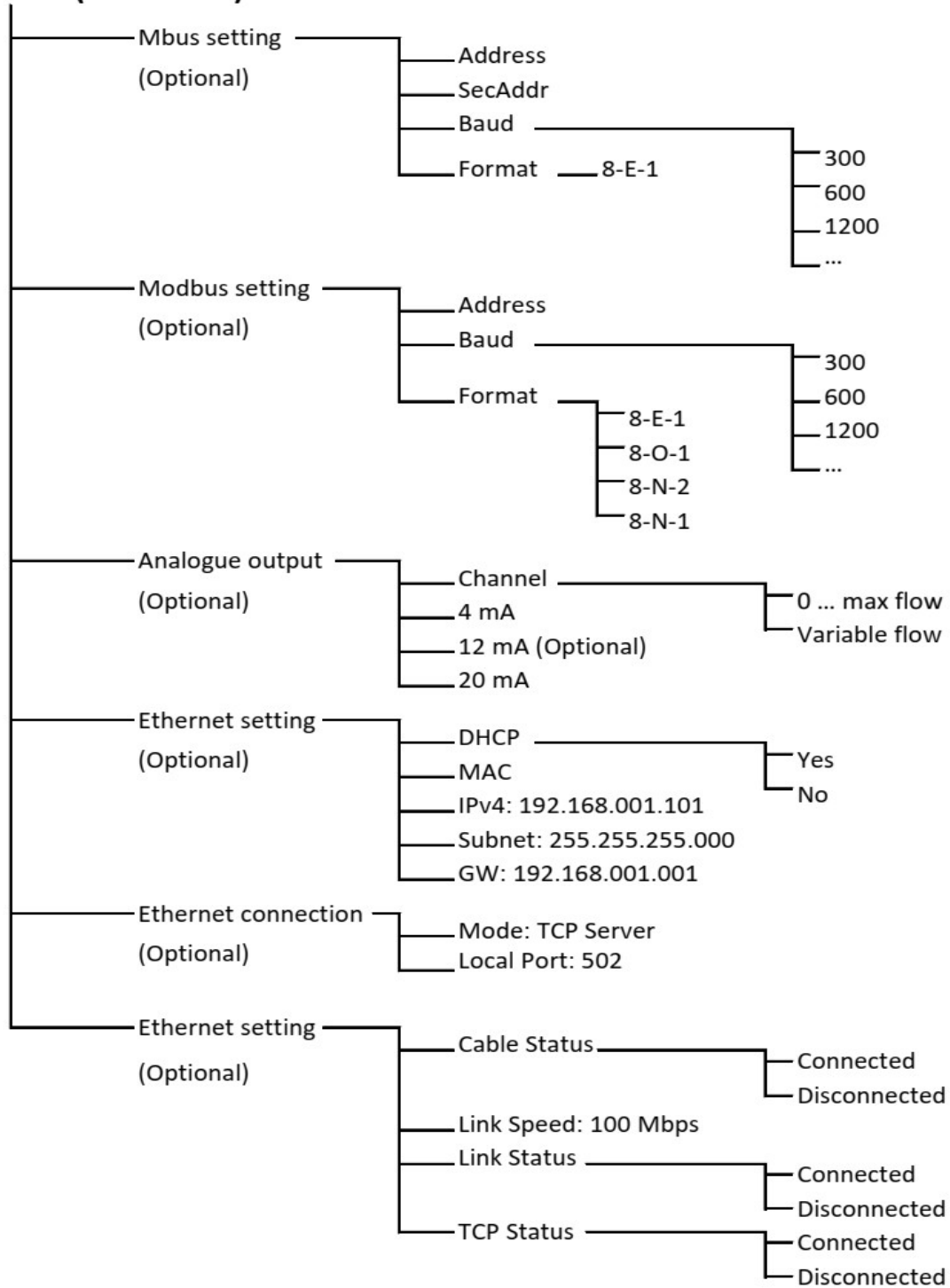

12 Calibration

The instrument is calibrated ex-work. The exact calibration date is printed on the certificate which is supplied together with the flow meter. The accuracy of the flow meter is regulated by the onsite conditions, and parameters such as oil, high humidity, or other impurities can affect the calibration and the accuracy.

It is recommended the instrument be calibrated at least once per year. The calibration is excluded from the instrument warranty. For more information about the calibration service, please contact the manufacturer.

13 Maintenance

To clean the device, it is recommended to use distilled water or isopropyl alcohol only.



ATTENTION!

Do not touch the surface of the sensor element to avoid damage!

Avoid mechanical impact on the device. For example, use a sponge or a brush to clean the instrument.

If the contamination can not be removed, send the device to the manufacturer for inspection and maintenance.

14 Disposal of Waste



Electronic devices are recyclable material and do not belong in household waste.

The flow meter, the accessories, and its packings must be disposed of according to your local statutory requirements. The waste can also be carried by the manufacturer of the product. For this, please contact the manufacturer.

15 Appendix - Flow Conditioner

The flow conditioner is an essential component for installations where the straight inlet can not be maintained. The conditioner ensures accurate measurement by conditioning the flow before it reaches the flow meter.

The flow conditioner can reduce the minimum inlet straight section to the length of 5 to 8 times of pipe diameter. The conditioner works in a way that the resulted downstream conditions in the pipe are fully developed, independent from the upstream conditions.

Note: The flow conditioner is specifically designed to be mounted directly onto R-thread measuring sections.

15.1 Dimension

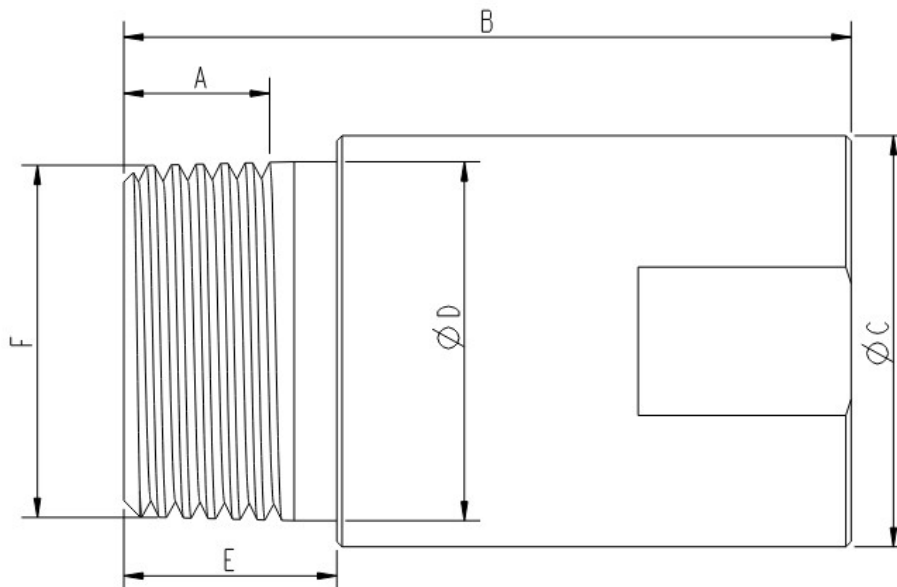

Unit: mm

Size	A	B	ΦC	ΦD	E	F
DN15	≥ 13.2	56.0	29.0	21.4	17.0	R1/2"
DN20	≥ 14.5	62.0	38.0	26.6	17.0	R3/4"
DN25	≥ 16.8	68.3	38.6	33.7	20.0	R1"
DN32	≥ 19.1	81.7	52.6	42.4	25.0	R1-1/4"
DN40	≥ 19.1	86.8	64.4	48.4	25.0	R1-1/2"
DN50	≥ 23.4	105.7	79.1	59.5	29.0	R2"
DN65	≥ 26.7	130.0	104.0	75.8	36.0	R2-1/2"
DN80	≥ 29.8	131.5	129.0	88.5	36.0	R3"

15.2 Installation

Follow the instructions below to ensure proper installation:

- Pre-installed configuration
 - If you have ordered the flow conditioner with the flow meter, it will be pre-installed at the factory. This means that the flow meter is calibrated together with the flow conditioner, ensuring optimum performance and accuracy right out of the box.
- Separate or retrofit installation and re-calibration
 - In cases where the flow conditioner is purchased separately or as a retrofit to an existing installation, it is important to re-calibrate the flow meter with the newly installed flow conditioner to ensure accurate measurements.
 - To re-calibrate the flow meter, please contact your sales representative. They will provide further guidance and assistance to ensure that the re-calibration process is carried out correctly.

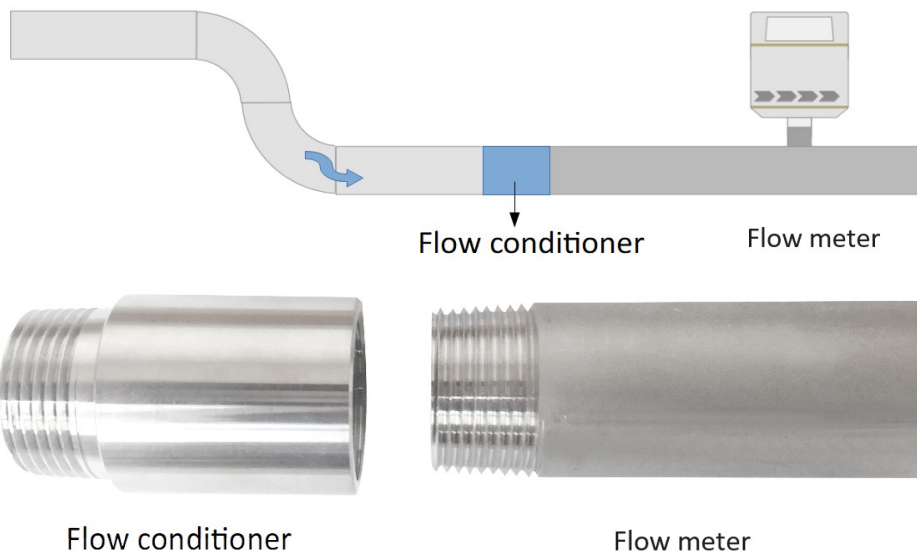

By following these instructions, you can ensure that your flow conditioning system is properly installed and maintains the highest level of measurement accuracy.

15.3 Ordering Information

Item No.	Measuring section (R-thread)
A1071	DN15
A1072	DN20
A1073	DN25
A1074	DN32
A1075	DN40
A1076	DN50
A1077	DN65
A1078	DN80

SUTO iTEC GmbH

Grißheimer Weg 21
D-79423 Heitersheim
Germany

Tel: +49 (0) 7634 50488 00
Email: sales@suto-itec.com
Website: www.suto-itec.com

SUTO iTEC (ASIA) Co., Ltd.

Room 10, 6/F, Block B, Cambridge Plaza
188 San Wan Road, Sheung Shui, N.T.
Hong Kong

Tel: +852 2328 9782
Email: sales.asia@suto-itec.com
Website: www.suto-itec.com

SUTO iTEC Inc.

5460 33rd St SE
Grand Rapids, MI 49512
USA

Tel: +1 (616) 800-7886
Email: sales.us@suto-itec.com
Website: www.suto-itec.com

All rights reserved ©

Modifications and errors reserved

S421_IM_EN_V2026-1
